



CITY OF TAMPA

Bob Buckhorn, Mayor

CONTRACT ADMINISTRATION DEPARTMENT

David L. Vaughn, AIA, Director

ADDENDUM NO. 1

DATE: January 27, 2014

Contract 13-C-00042; Downs Pumping Station Rehabilitation – Sheltered market

Bidders on the above referenced project are hereby notified that the following addendum is made to the Contract Documents. BIDS TO BE SUBMITTED SHALL CONFORM TO THIS NOTICE.

- Item 1: Pump Station location clarification: the address listed in the bid documents is incorrect. Refer to the attached maps for the correct pump station location.
- Item 2: Replace Workmanship and Materials Sub-section 46.09 Sewage Pump Controller/SCADA/Radio (PCSR) with the attached, revised Workmanship and Materials Sub-section 46.09
- Item 3: Replace Plan Sheets E11 and E14 with the attached, revised plan sheets E11 and E14.

All other provisions of the Contract Documents and Specifications not in conflict with this Addendum shall remain in full force and effect. Questions are to be e-mailed to Contract Administration@tampagov.net.

Jim Greiner

Jim Greiner, P.E., Contract Management Supervisor

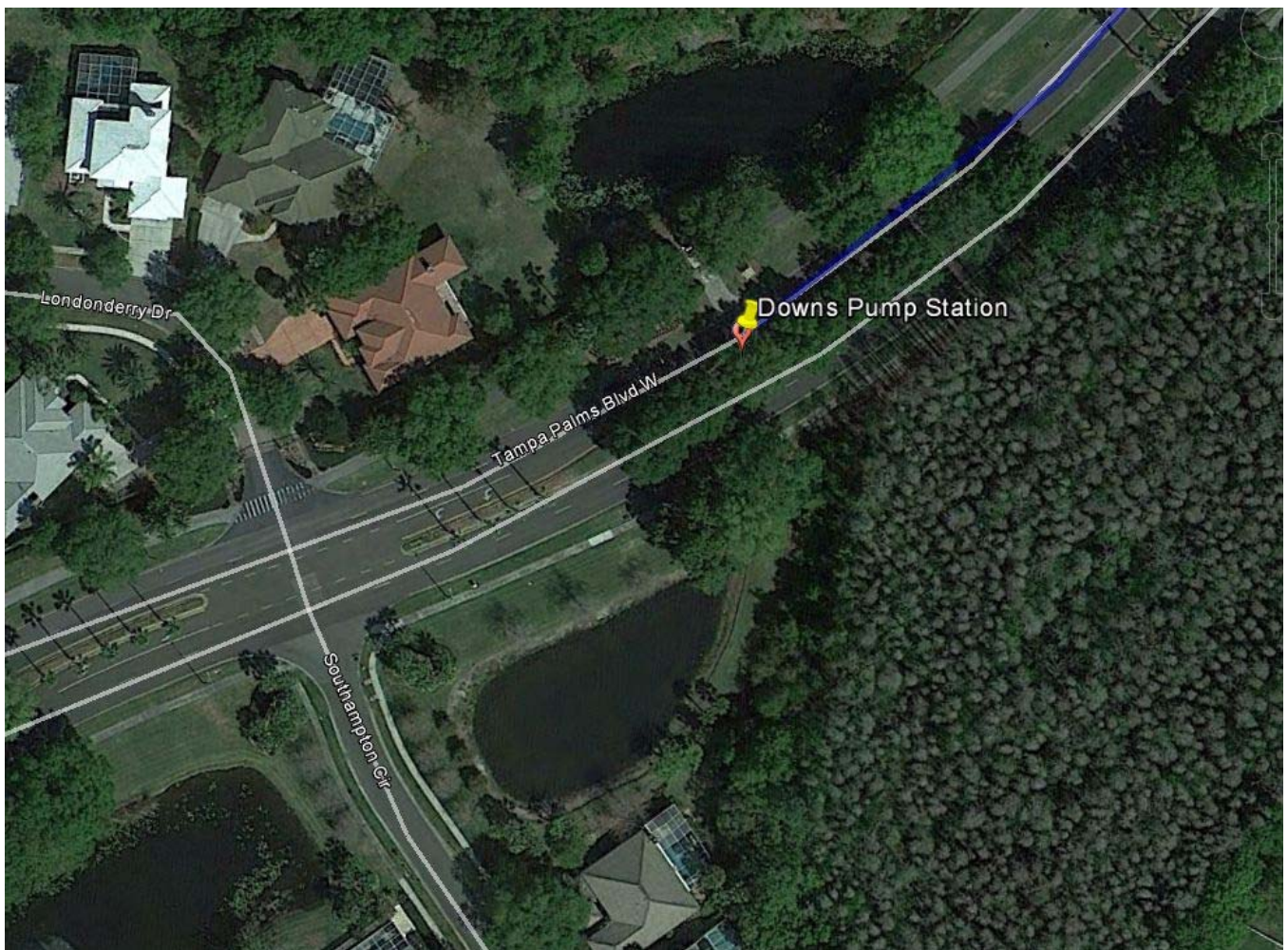
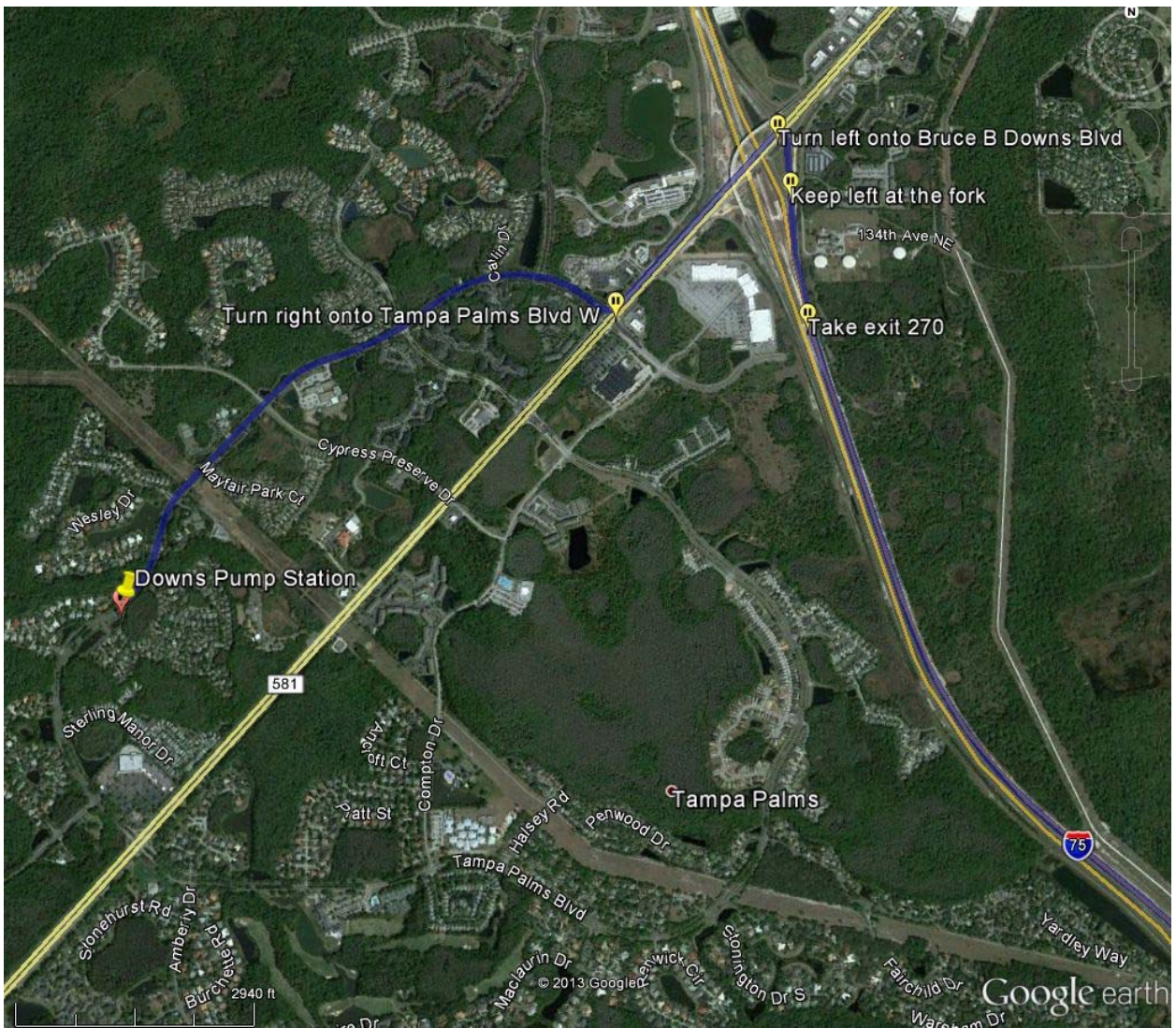

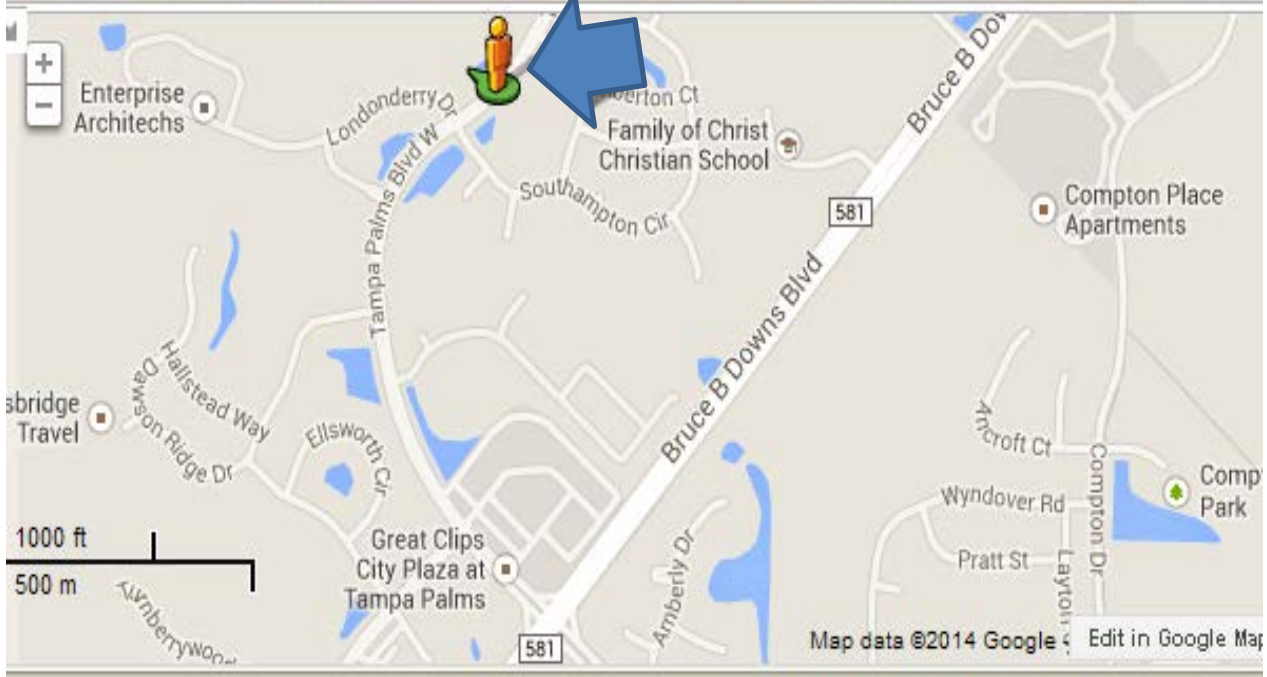

Downs Pump Station Location

Tampa Palms Blvd W, East of Londonderry Dr.

W-46.09 Sewage Pump Controller / SCADA / Radio (PCSR)

The Sewage Pump Controller / SCADA / Radio subassembly comprises a programmable logic controller (PLC) based system engineered to provide duplex pump control, supervisory control and data acquisition (SCADA), and radio telemetry in one assembled package. The components shall be mounted on an aluminum sub-panel and be fully wired, tested, and ready for field connections via conveniently located interface terminals. The subassembly shall operate on a 120 Volt, 60 Hz, single-phase power supply and shall have integral transient voltage protection.

The PCSR shall be a Motorola ACE3600 package as distributed by DCR Engineering Services Inc., ScadaOne, LLC, or Revere Control Systems. The Contractor shall coordinate his efforts with DCR, Inc. , ScadaOne, LLC, or Revere Control Systems to ensure system compatibility, performance, and security. The Contractor shall provide and install a complete control system package as programmed by DCR, Inc., ScadaOne, LLC, or Revere Control Systems. The existing Pump Station DCR controls shall revert to the City as a spare.

The following is a partial list of PCSR features:

1. Motorola ACE3600 remote terminal unit (RTU) with surge / lightning protection for power line and antenna shall be provided.
2. One Mixed I/O modules shall be provided.
3. A Motorola CDM750 conventional radio, UHF band (403-512 MHz), shall be provided.
4. The pump controller shall operate independently of the SCADA / telemetry system in the event of communications loss.
5. DC power circuits derived from the RTU and feeding external loads shall be individually fused as required. Fuses shall have indicator LEDs to indicate fuse has blown.
6. A back-up pump controller shall be provided to facilitate emergency overflow protection in the event of RTU failure.
7. Interposing control relays shall be provided as required.
8. Terminal blocks shall be arranged, and separated as follows: main power distribution block; 120VAC power; 24VDC power; RTU DC power bus.
9. All wires shall be permanently identified using a computer generated labeling system. All terminal numbers and identifying nomenclature shall correspond to and be shown on the electrical diagrams and schematics.
10. All external wiring shall terminate on terminal blocks.
11. The RTU shall provide both digital and analog inputs for use in monitoring and control. Simultaneous monitoring of analog and digital level sensing devices shall be supported where the analog level sensing device shall be primary. The RTU shall contain routines for detecting sensor failures and utilize the alternate level sensing device(s).
12. Battery back-up power shall be provided for the RTU so that monitoring is maintained during Utility power failures. The batteries shall have the capacity of operating the RTU for a minimum of four hours. The power supply shall keep the batteries at float charge. The RTU shall contain a low battery cutout circuit, and the batteries shall not be damaged by deep discharges.
13. Local manual pump control is provided by Hand-Off-Auto (HOA) switches located in the pump control panel. In the absence of RTU power or in the case of RTU failure, the pump

motor starters shall remain operational in the HAND position. In no case shall the RTU have the capability to operate or override the pumps in the HAND or OFF positions.

14. The capability to remotely override or disable individual pumps shall be provided (local switches must be in the AUTO position).
15. The RTU shall have the capability to test the back-up pump controller by creating a high level condition and verifying that the back-up controller functions properly. In the event of a controller failure, the RTU will send an alarm to the Central HMI.
16. Capability shall be provided to configure from two to four pumps.
17. Individual pump run status shall be reported to the Central HMI.
18. The following pump failures shall be reported to the Central HMI: fail to start; fail to stop; premature stop; drive fault; and stator over temperature.
19. RTU configuration parameters shall be adjustable locally and remotely from the Central HMI.
20. A fail-safe input shall be provided indicating cabinet intrusion.
21. The RTU shall have the latest RTU SCADA application license compatible with the existing Central HMI configuration.

NOTES

1. TECO SERVICE: PROP. 277/480V, 3φ, 4W, WYE CALCULATED FAULT CURRENT- 6939A PROPOSED 150 AMP, CB1 AIC RATING - 35,000A SYMMETRICAL.
2. THE WET WELL CLASSIFICATION IS CLASS I, DIVISION 2, GROUP D, (HAZARDOUS AREA) NEC, CHAPTER 5 IS APPLICABLE FOR INTERFACING WET WELL AND THE CONTROL ENCLOSURE.
3. ALL ELECTRICAL WORK SHALL BE PERFORMED WITHIN LATEST EDITION OF THE NEC ADOPTED BY THE STATE OF FLORIDA AND CITY OF TAMPA/HILLSBOROUGH COUNTY CODES AND SHALL BE INSPECTED BY CITY OF TAMPA/HILLSBOROUGH COUNTY ELECTRICAL INSPECTORS AS APPLICABLE.
4. ALL ELECTRICAL COMPONENTS SHALL BE UL LISTED AND AS SPECIFIED, OR AS APPROVED BY THE ENGINEER. THE PANEL BUILDER SHALL BE UL-508A CERTIFIED AND A UL LABEL SHALL BE ATTACHED TO THE INSIDE OF THE ENCLOSURE.
5. THE ENCLOSURE SHALL BE NEMA 3, SHALL BE CONSTRUCTED OF MINIMUM 14 GAUGE 304 S.S. SHALL HAVE RAL 9003 WHITE POWDER COAT SURFACE, AND THE CLOSING SURFACE SHALL HAVE ROLLED LIPS. PROVIDE HINGED DOOR WITH 3-POINT LATCH AND LOCKABLE HANDLE. REFERENCE PART SCHEDULE.
6. ALL COMPONENTS TO BE MOUNTED ON PANEL USING TAPPED HOLES.
7. ALL WIRING SHALL BE COPPER. ALL CONTROL WIRING SHALL BE STRANDED THWN COPPER, MINIMUM AWG #14, AND SHALL HAVE SPADE LUG TERMINATIONS.
8. ALARM FLOAT SWITCH WILL BE SUPPLIED BY THE CITY BUT INSTALLED BY CONTRACTOR.
9. DIMENSIONS, ITEMS, OR ELEVATIONS MARKER '*' TO BE DETERMINED AFTER EQUIPMENT SELECTION.
10. ALL MECHANICAL CONNECTORS SHALL BE TORQUED PER NEC, UL OR MANUFACTURERS SPECIFICATIONS.
11. INSTALL LAMINATED SCHEMATIC AND LAMINATED DATA SHEET ON BACK FACE OF THE DOOR INSIDE THE ENCLOSURE.
12. ENSURE THAT THE LINE CONNECTIONS TO METER SOCKET PROVIDE CORRECT ROTATION.
13. ROUTE AND SECURE SERVICE ENTRANCE CONDUCTORS SO AS NOT TO INTERFERE WITH OR CONTACT EQUIPMENT AND COMPONENTS IN THE PANEL. ALSO, PROVIDE SPACING BETWEEN THE ENCLOSURE AND ALL CONDUCTORS.

14. CONDUCTORS WITHIN THE ENCLOSURE AND NOT ROUTED IN WIREWAYS, SHALL BE SECURED TO THE BACKPANEL WITH MECHANICAL FASTENERS. FASTENERS SECURED WITH ADHESIVE ARE NOT ACCEPTABLE.
15. ALL HINGED SURFACES SHALL BE GROUNDED WITH A BONDING JUMPER SECURED TO THE ENCLOSURE OR BACKPANEL.
- △ 16. THE PCSR SHALL BE A MOTOROLA ACE 3600 PACKAGE AS DISTRIBUTED BY DCR ENGINEERING SERVICES INC., SCADAONE, LLC., OR REVERE CONTROL SYSTEMS. THE PUMPING STATION CONTRACTOR SHALL COORDINATE HIS EFFORTS WITH DCR, SCADAONE, OR REVERE CONTROL SYSTEMS TO ENSURE SYSTEM COMPATIBILITY. THE CONTRACTOR SHALL PROVIDE AND INSTALL A COMPLETE DUPLEX CONTROL SYSTEM/SCADA PACKAGE, AS PROGRAMMED BY DCR, SCADAONE, OR REVERE CONTROLS-- THE EXISTING PUMPING STATION DCR CONTROLS SHALL REVERT TO THE CITY AS A SPARE.
17. A WET WELL LEVEL DETECTION SYSTEM SHALL BE PROVIDED AND INSTALLED BY THE CONTRACTOR. THE OUTPUT SHALL BE A LINEAR 4-20 mA SIGNAL WITH RANGE AND CALIBRATION SUITABLE FOR THIS APPLICATION. THE SYSTEM SHALL BE OF THE ULTRASONIC TYPE-- PULSAR, INC. MODEL dB10 W/BLACKBOX 130 TRANSMITTER. CITY INSTRUMENTATION PERSONNEL WILL ASSIST THE CONTRACTOR WITH SPECIFYING THE TRANSDUCER MOUNTING LOCATION AND CALIBRATION. THE dB10 TRANSDUCER SHALL BE MOUNTED USING A STAINLESS STEEL BRACKET, SEE PULSAR MOUNTING BRACKET DETAIL, SHEET E14. THE EXISTING PUMPING STATION WET WELL LEVEL DETECTION SYSTEM SHALL REVERT TO THE CITY AS A SPARE.
18. PROVIDE 1/4" MINIMUM THICKNESS LEXAN SHIELDS OVER POWER DISTRIBUTION BLOCK AND OTHER EXPOSED CABLE TERMINATIONS.
19. REMOVE AND REPLACE EXISTING ABOVE GRADE CONDUIT AND REUSE THE BELOW GRADE PVC CONDUIT FROM THE TECO METER TO THE EXISTING PAD MOUNTED TRANSFORMER 271 00 47 25, REPLACE ALL CONDUCTORS. FIELD VERIFY LOCATION OF EXISTING PAD MOUNTED TRANSFORMER PRIOR TO COMMENCING WITH WORK.

PUMP MOTOR DATA

MAKE: FLYGT
 MODEL: NP3153.181
 HP : 20.0
 460 V, 3 PHASE, 26.0 FLA

TOTAL PUMP LOAD: 52 AMPS, 43.2 KVA

ROMAN D. KORCHAK, P.E. #42626 ELECTRICAL SECTION HEAD WASTEWATER DEPARTMENT	No.	DATE	REVISIONS	DES: LRG	CITY of TAMPA WASTEWATER DEPARTMENT LRG	DOWNS PUMP STATION REHABILITATION ELECTRICAL NOTES FOR SHEETS E5 - E10	W.O. 5899
	3			DRN: LRG			SHEET
	2			CKD:			EII
	△	1/24/2014	ADDENDUM #1	DATE:			

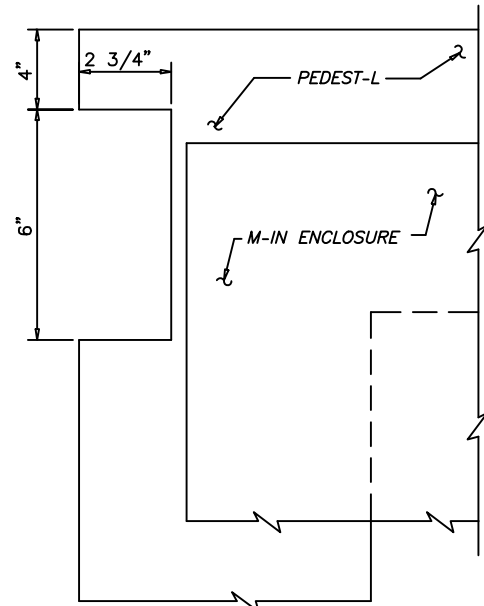

NOTCH IN PEDESTAL DETAIL

NOT TO SC-LE

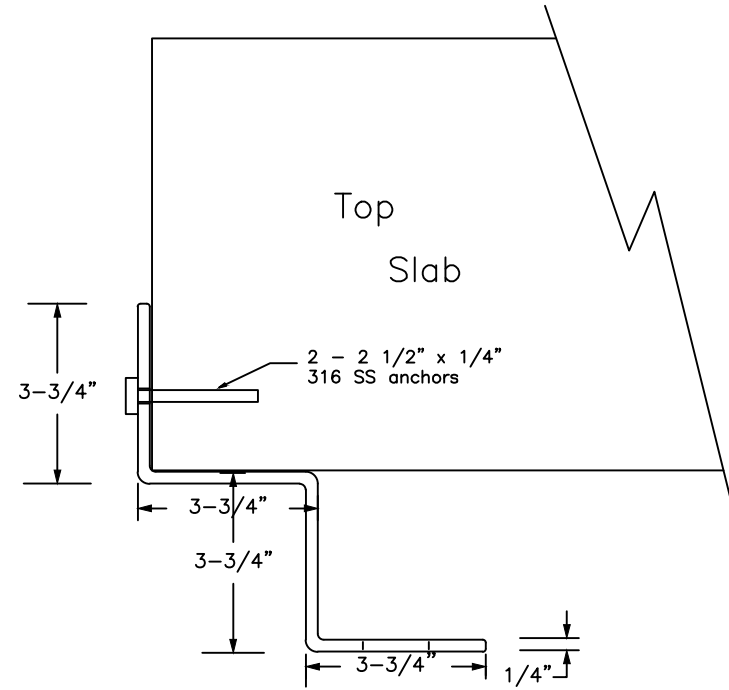

PULSAR MOUNTING BRACKET DETAIL

NOT TO SC-LE

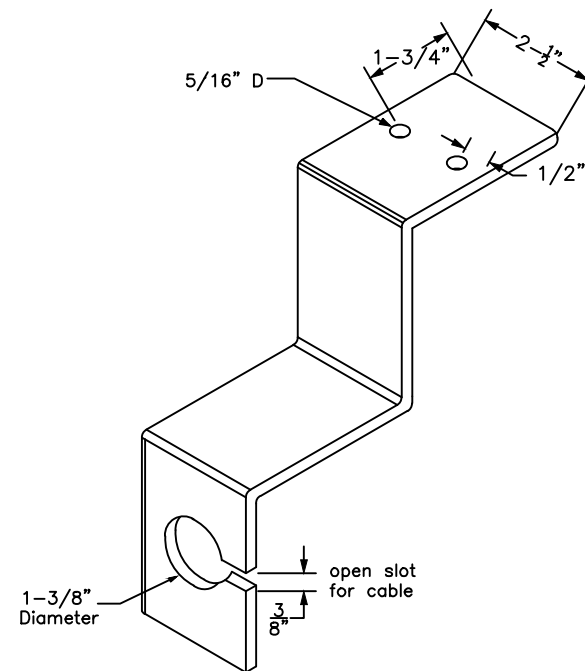

- NOTES:
 1. ROUND OVER -LL EDGES
 2. R-DIUS -LL CORNERS
 3. USE 316 ST-INLESS STEEL M-TERI-L

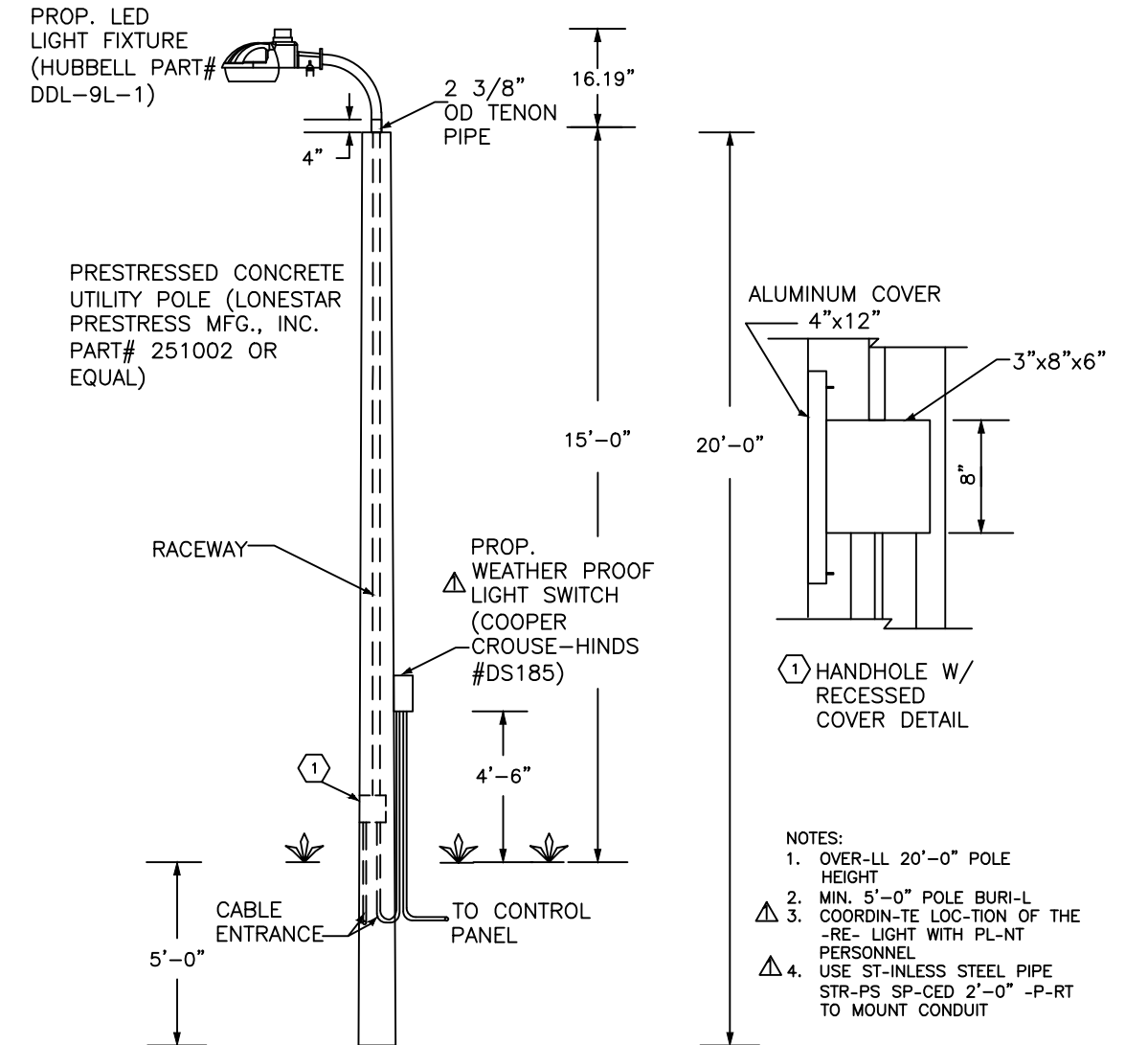

AREA LIGHT DETAIL

NOT TO SC-LE

- NOTES:
 1. OVER-LL 20'-0" POLE HEIGHT
 2. MIN. 5'-0" POLE BURI-L
 3. COORDIN-TE LOC-TION OF THE -RE- LIGHT WITH PL-NT PERSONNEL
 4. USE ST-INLESS STEEL PIPE STR-PS SP-CED 2'-0" -P-RT TO MOUNT CONDUIT

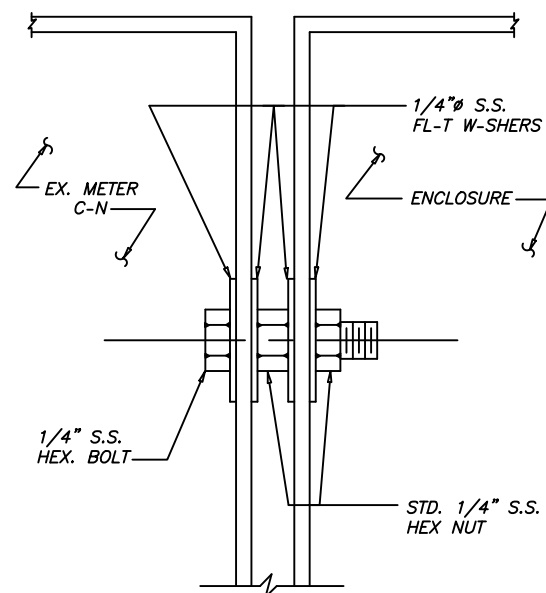

METER CAN CONNECTION

NOT TO SC-LE

SEE NOTES ON SHEET E15

ROM-N D. KORCH-K, P.E. #42626
 ELECTRIC-L SECTION HE-D
 W-STEW-TER DEP-RTMENT

No.	DATE	REVISIONS
3		
2		
Δ	1/24/2014	-DDENDUM #1

DES: LRG
 DRN: LRG
 CKD:
 D-TE:

CITY of TAMPA
WASTEWATER DEPARTMENT

DOWN'S PUMP STATION
REHABILITATION
ELECTRICAL DETAILS

W.O. 5899

SHEET
E14