



CITY OF TAMPA

Bob Buckhorn, Mayor

CONTRACT ADMINISTRATION DEPARTMENT

Michael W. Chucran, Director

ADDENDUM NO. 2
DATE: April 7, 2016

Contract 15-C-00045; Tampa International Airport Pump Station Rehabilitation

Bidders on the above referenced project are hereby notified that the following addendum is made to the Contract Documents. BIDS TO BE SUBMITTED SHALL CONFORM TO THIS NOTICE.

- Item 1: Replace plan sheet E23 with the attached plan sheet E23.
- Item 2: Delete Workmanship and Materials Section 50 in its entirety.
- Item 3: Attached is a copy of the pre-bid meeting sign-in sheet.
- Item 4. Maintenance Of Traffic clarification: The service road near the pumpstation will need to be closed in order to construct project. The alternate south access will need to remain open.
- Item 5. Temporary Power Clarification: Per SP-67 Interruption of Service, the Contractor shall make provisions and pay for temporary power used by him in performing this work. See the following table for the electric bill information for the existing Airport Pump station from April/2015 – March/2016.

TI Airport Billing

Bill Begin Date	Bill End Date	Total Cost	Cost Per Day	Bill Entry Date
04/02/2015	05/05/2015	572.84	17.36	05/08/2015
05/05/2015	06/03/2015	521.67	17.99	06/08/2015
06/03/2015	07/02/2015	452.33	15.60	07/08/2015
07/02/2015	08/03/2015	578.62	18.08	08/06/2015
08/03/2015	09/02/2015	566.42	18.88	09/09/2015
09/02/2015	10/01/2015	474.20	16.35	10/06/2015
10/01/2015	11/02/2015	432.57	13.52	11/06/2015
11/02/2015	12/03/2015	558.02	18.00	12/07/2015
12/03/2015	01/06/2016	584.64	17.20	01/08/2016
01/06/2016	02/04/2016	391.82	13.51	02/08/2016
02/04/2016	03/04/2016	500.90	17.27	03/09/2016

All other provisions of the Contract Documents and Specifications not in conflict with this Addendum shall remain in full force and effect. Questions are to be e-mailed to Contract Administration@tampagov.net.

Jim Greiner

Jim Greiner, P.E., Contract Management Supervisor

306 E. Jackson Street, 4N • Tampa, Florida 33602 • (813) 274-8456 • FAX: (813) 274-8080



1

LIGHTING FIXTURE SCHEDULE						
TYPE	MANUFACTURER	CATALOG NUMBER	LAMP(S)	VOLTS	MOUNTING	REMARKS
A	LITHONIA	ZL2N L48 3000LM MDD MVOLT 40K 80CRI WH	(2) 32W T8	120	CEILING	LED STRIP FIXTURE.
B	LITHONIA	TWH LED 30C 1000 50K T3M 120 DDBXD	(1) 104W DRIVER	120	WALL	LED WALLPACK LUMINAIRE. U.L. WET LABEL.
EM	LITHONIA	ELM2 LED	(2) 1.6 W LED	120/277	WALL	LED EMERGENCY LIGHT
X	LITHONIA	LQMP3R120/277ELN	(1) 1W DRIVER	120/277	UNIVERSAL	LED EXIT SIGN WITH NICKEL CADMIUM BATTERY BACKUP

PROPOSED PANEL SCHEDULE														
PANEL 'LP' ; SQUARE D CO. MINI POWER-ZONE			120/240 VOLTS, 1Ø, 3W			30 AMP MAIN CIRCUIT BREAKER			PROVIDE EQUIPMENT GROUND BAR ;			SURFACE ENCLOSURE TOP AT 5'-6" AFF		
EQUIPMENT SERVED	CIRCUIT BREAKER			KVA/PHASE		CIRC.		KVA/PHASE		CIRCUIT BREAKER			EQUIPMENT SERVED	
	POLE	AMPS	FRAME	A	B	NO.	NO.	A	B	POLE	AMPS	FRAME		
GENERATOR ROOM LIGHTS	1	20	QOB	0.5		1	2	0.1		1	20	QOB	FLOW METER	
GENERATOR ROOM RECEPTACLE	1	20	QOB		0.2	3	4		1.2	1	20	QOB	GENERATOR BATTERY CHARGER	
ODOR CONTROL UNIT POWER	1	20	QOB	1.2		5	6			---	---	---	SPACE	
SPACE	---	---	---			7	8			---	---	---	SPACE	
SPACE	---	---	---			9	10			---	---	---	SPACE	
SUB-TOTAL KVA				1.7	0.2			0.1	1.2					
TOTAL CONNECTED LOAD = 3.2 KVA						TOTAL DEMAND LOAD = 3.2 KVA								

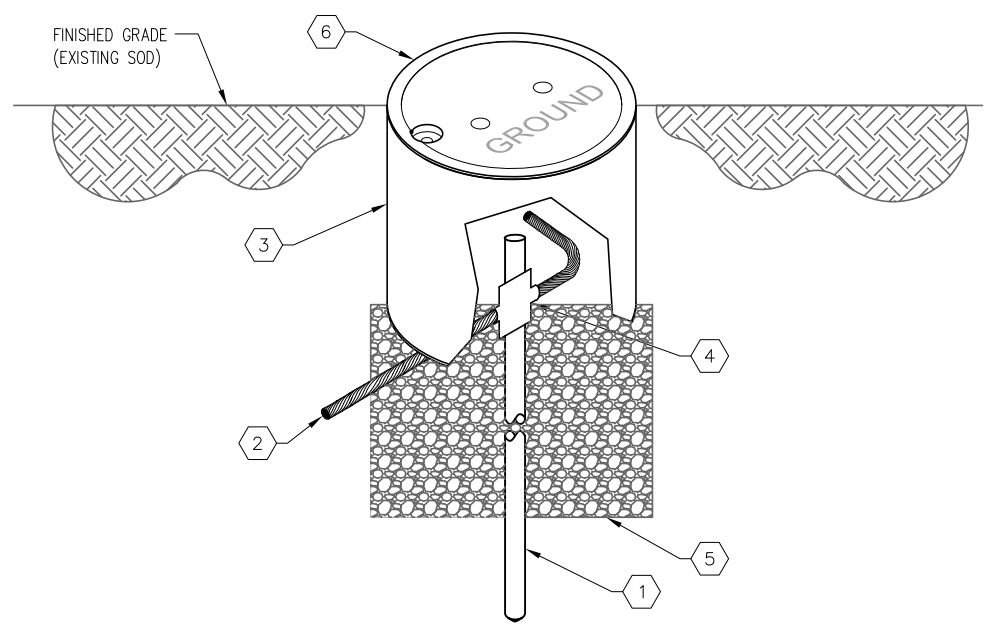

- GROUND TEST WELL DETAIL KEYED NOTES:**
- 1 NEW GROUND ROD, STAINLESS STEEL, 5/8" X 10'-0" (TYP).
 - 2 #4 BARE STRANDED COPPER GROUNDING ELECTRODE CONDUCTOR (# 8 FOR MINI POWER-ZONE GROUNDING).
 - 3 PROVIDE AND INSTALL HARGER 362PS12CILS80, SCHEDULE 80 PVC GROUND TEST WELL (TYP).
 - 4 EXOTHERMIC WELD.
 - 5 PROVIDE 6" MINIMUM OF CRUSHED STONE.
 - 6 GROUND TEST WELL CAST IRON COVER.

GROUND TEST WELL DETAIL
SCALE : N.T.S.

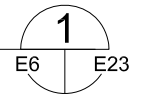

TIMOTHY THOMAS, P.E. #47079	No.	DATE	REVISIONS	DES: T.D.T.	CITY of TAMPA WASTEWATER DEPARTMENT	TAMPA INTERNATIONAL AIRPORT MAIN PUMPING STATION SCHEDULES AND DETAILS	W.O. 5967
	3			DRN: J.L.H.			SHEET
	2			CKD: T.D.T.			E23
	1	4-5-2016	REVISED LIGHTING FIXTURE SCHEDULE	DATE: 1-27-16			

E-Mail to Register as a Plan Holder and E-Mail All Questions to: ContractAdministration@tampagov.net

Sign-In Sheet Please Print

City of Tampa, Contract Administration Department

	Name	Organization	E-Mail OR Phone
2	Jody Gray	Tampa Contract Administration Dept.	Jody.Gray@tampagov.net
3	Ayyappan Pillai	JOHN Group INTL	apillai@jgicorp.com
4	Bob Robinson	Sheppard Elect. Svcs.	bobr@chisesinc.com
5	Jimmy Thibeault	" " "	JimmyT22@chisesinc.com
6	Leon Lee	MARK One Power	leon.markonepower@gmail.com
7	Renee Baxter	RTD Construction Inc	bids@rtdconstruction.com
8	CHRIS BARRETT	WHARLOW-SMITH	CBARRETT@WHARLOWSMITH.COM
9	Dalas Lamberson	TLC Diversified, Inc.	bids@TLCDIV.COM
10	D. Kloote	KLOOTE	D.K@KLOOTE.COM
11	P Zacharias	AWTP	
12	N. Collins	Contract Admin	
13	JACK FERRAS	COT - WASTEWATER	JACK.FERRAS@TAMPAGOV.NET
14	TIM THOMAS	TRICON	tthomas@tricon-eng.com
15	Lashonda Green	C.O.T	lashonda.green@tampagov.net
16	ROMAN KORCHAK	C.O.T RLEC. RUGG	ROMAN.KORCHAK@TAMPAGOV.NET
17	Kevin Schels	COT AWTP	Kevin.Schels@tampagov.net
18	Joe Striker	COT AWTP	Joseph.Striker@Tampagov.net
19	Jed Church	Bodwin Pumps	jed.church@xyleminc.com
20	Jamie Graham	Sunbelt Rentals	Jamie.Graham@SunbeltRentals.com
21	CARMEN RODRIGUEZ	COT - CAD	carmen.rodriguez@tampagov.net
22	Clay Goodison	Mahey	C.Goodison@mahey.com
23	John Babatka	Manatee Electric, Inc. (SLBE)	john@reliableelectricusa.com
24			
25			
26			
27			
28			
29			
30			
31			
32			
33			
34			
35			
36			