



CITY OF TAMPA

Bob Buckhorn, Mayor

CONTRACT ADMINISTRATION DEPARTMENT

Michael W. Chucran, Director

ADDENDUM NO.2

DATE: February 9, 2017

Contract 17-C-00018; Lois Pumping Station Driveway- Sheltered Market

Bidders on the above referenced project are hereby notified that the following addendum is made to the Contract Documents. BIDS TO BE SUBMITTED SHALL CONFORM TO THIS NOTICE.

Item 1: Replace the Specifications with the attached, revised Specifications.

All other provisions of the Contract Documents and Specifications not in conflict with this Addendum shall remain in full force and effect. Questions are to be e-mailed to ContractAdministration@tampagov.net.

Jim Greiner

Jim Greiner, P.E., Contract Management Supervisor

The Enclosed Document Is Provided For Your Convenience.

Please Email ALL Questions:
[MailTo:ContractAdministration@TampaGov.net](mailto:ContractAdministration@TampaGov.net)

Please Let Us Know If You Plan To Bid

City of Tampa
Contract Administration Department
306 E. Jackson St. #280A4N
Tampa, FL 33602
(813)274-8456

CITY OF
TAMPA, FLORIDA

NOTICE TO BIDDERS, INSTRUCTIONS TO BIDDERS
PROPOSAL, BID BOND, FORM OF NOTICE OF AWARD,
AGREEMENT, PERFORMANCE BOND AND
SPECIFICATIONS

FOR

Contract 17-C-00018

Lois Pumping Station Driveway

SHELTERED MARKET

City of Tampa
CONTRACT ADMINISTRATION DEPARTMENT
TAMPA MUNICIPAL OFFICE BUILDING
306 E. JACKSON STREET - 4TH FLOOR NORTH
TAMPA, FLORIDA 33602

Revised February 9, 2017
Addendum No. 2

FEBRUARY 2017

CITY OF TAMPA
CONTRACT ADMINISTRATION DEPARTMENT
306 E. Jackson Street 280A4N
Tampa, FL 33602

BID NOTICE MEMO

Bids will be received no later than 1:30 p.m. on the indicated Date(s) for the following Project(s):

Only City of Tampa Certified Small Local Business Enterprises / Underutilized WMBEs may submit bids for this project.

CONTRACT NO.: 17-C-00018; Lois Pumping Station Driveway Sheltered Market

BID DATE: March 07, 2017 **ESTIMATE:** \$80,000 **SCOPE:** The project comprises furnishing all labor, materials and equipment to add an asphalt access driveway and retention pond as specified in construction plans with all associated work required for a complete project in accordance with the Contract Documents. **PRE-BID CONFERENCE:** Tuesday, February 21, 2017, 10:00 a.m., 4207 W. Oklahoma Ave., Tampa, FL 33616. Attendance is not mandatory, but recommended.

Bids will be opened in the 4th Floor Conference Room, Tampa Municipal Office Building, 306 E. Jackson Street, Tampa, Florida 33602. Pre-Bid Conference is held at the same location unless otherwise indicated. Plans and Specifications and Addenda for this work may be examined at, and downloaded from, www.demandstar.com. Backup files are available at <http://www.tampagov.net/contract-administration/programs/construction-project-bidding>. Subcontracting opportunities may exist for City certified Small Local Business Enterprises (SLBEs). A copy of the current SLBE directory may be obtained at www.Tampagov.net. Phone (813) 274-8456 for assistance. **Email Technical Questions to:** contractadministration@tampagov.net.

TABLE OF CONTENTS

BIDDING REQUIREMENTS

Notice to Bidders N-1
 Instructions to Bidders I-1a thru I-4
 Insurance Requirements INS-1 thru INS-2
 MBD Form-70 1
 Sample Solicitation Letter SL-1

BID FORMS

Proposal P-1 thru P-3
 Good Faith Efforts Compliance Plan GFECF
 SLBE Solicited DMI – Solicited
 SLBE Utilized DMI – Utilized
 Bid Bond BB-1

CONTRACT FORMS

Agreement A-1 thru A-15
 Public Construction Bond PB-1 thru PB-3

GENERAL PROVISIONS

General Provisions G-1 thru G-10
 Supplementary General Provisions SGP-1 thru SGP-6
 Special Conditions SC-1 thru SC-4
 Specific Provisions SP-1 thru SP-8
 Subcontractors Payment Form DMI – Payments
 Project Sign Sign-1 thru Sign-2

SPECIFICATION

Section 01010 – Summary of Work 01010-1 thru 01010-2
 Section 033000 – Cast-in-Place Concrete 033000-1 thru 033000-11
 Section 033010 – Concrete – General 033010-1 thru 033010-9
 Section 033020 – Concrete Formwork 033020-1 thru 033020-4
 Section 033030 – Concrete Reinforcement 033030-1 thru 033030-3
 Section 311004 – Sub-Surface Conditions 311004-1
 Section 311100 – Earthwork 311100-1 thru 311100-2
 Section 311110 – Earthwork for Structures 311110-1 thru 311110-7
 Section 312001 – Limerock Base 312001-1 thru 312001-4
 Section 312002 – Asphaltic Concrete Surface Course 312002-1 thru 312002-8
 Section 312003 – Dewatering 312003-1
 Section 312005 – Subgrade Stabilization 312005-1 thru 312005-4
 Section 312010 – Structural Excavation and Backfill 312010-1 thru 312010-4
 Section 312017 – Recycled Crushed Concrete Base 312017-1 thru 312017-5
 Section 312019 – Selective Demolition 312019-1 thru 312019-4

PLANS 10 Sheets of Drawings

NOTICE TO BIDDERS
CITY OF TAMPA, FLORIDA
Contract 17-C-00018; Lois Pumping Station Driveway

Sealed Proposals will be received by the City of Tampa no later than 1:30 P.M., March 07, 2017, in the 4th Floor Conference Room, Tampa Municipal Office Building, 306 E. Jackson Street, Tampa, Florida, there to be publicly opened and read aloud.

Only bids from current City certified Small Local Business Enterprises (SLBEs), or Underutilized Women/Minority Business Enterprises (WMBEs) within the industry category of "Construction" shall be considered (see MBD Form-70).

NOTE: The City of Tampa's WMBE policies are narrowly-tailored to identify Underutilized WMBEs by industry category. WMBE Bidders/Proposers who are certified in the Underutilized category for the work/score detailed herein are eligible for award. In all cases, the Bidder/Proposer must be WMBE and/or SLBE certified prior to the opening date and time of the bid/proposal. As proof of certification, include copies of the applicable City of Tampa WMBE and SLBE certificates in the bid/proposal.

The proposed work is to include, but not be limited to, furnishing all labor, materials and equipment to add an asphalt access driveway and retention pond as specified in construction plans with all associated work required for a complete project in accordance with the Contract Documents.

The Instructions to Bidders, Proposal, Form of Bid Bond, Agreement, Form of Public Construction Bond, Specifications, Plans and other Contract Documents are posted at DemandStar.com. Backup files may be downloaded from <http://www.tampagov.net/contract-administration/programs/construction-project-bidding>. One set may be available for reference at the office of the Contract Administration Department, Municipal Office Building, Fourth Floor North, City Hall Plaza, Tampa, Florida 33602.

Each Proposal must be submitted on the Proposal form included in the Specifications and must be accompanied by a certified check or cashier's check on a solvent bank or trust company in compliance with Section 255.051, Florida Statutes, made payable to the City of Tampa, in an amount of not less than five per cent of the total bid, or a Bid Bond, of like amount, on the form set forth in the Contract Documents, as a guarantee that, if the Proposal is accepted, the Bidder will execute the Proposed Contract and furnish a Public Construction Bond within twenty (20) days after receipt of Notice of Award of Contract.

To be eligible to submit a proposal, a Bidder must hold the required and/or appropriate current license, certificate, or registration (e.g. DBPR license/certificate of authorization, etc.) in good standing at the time of receipt of Bids. **Per Section 489.131, Florida Statutes, Proposals submitted for the construction, improvement, remodeling, or repair of public projects must be accompanied by evidence that the Bidder holds the required and/or appropriate current certificate or registration, unless the work to be performed is exempt under Section 489.103, Florida Statutes.**

The City of Tampa reserves the right to reject any or all Bids and to waive any informalities in the Bid and/or Bid Bond. Acceptance or rejection of Proposals will be made as soon as practicable after the Proposals are received, but the City reserves the right to hold Proposals for ninety (90) days from the date of Opening.

Bid Protest Procedures: Unless subsequently indicated otherwise, in a revised posting on the Department's web page for Construction Project Bidding, the City of Tampa intends to award the referenced project to the lowest bidder listed in the tabulation posted on or about the date of Bid Opening. A bidder aggrieved by this decision may file a protest not later than 4:30 P.M., five (5) business days from the first posting thereof, pursuant to City of Tampa Code Chapter 2, Article V, Division 3, Section 2-282, Procurement Protest Procedures. Protests not conforming therewith shall not be reviewed.

Any Requests For Information must be submitted by email to ContractAdministration@tampagov.net

A person or affiliate who has been placed on the convicted vendor list following a conviction for a public entity crime may not submit a bid on a contract to provide any goods or services to a public entity, may not submit a bid on a contract with a public entity for the construction or repair of a public building or public work, may not submit bids on leases of real property to a public entity, may not be awarded or perform work as a contractor, supplier, subcontractor, or consultant under a contract with any public entity, and may not transact business with any public entity in excess of the threshold amount provided in Section 287.017, for CATEGORY TWO for a period of 36 months from the date of being placed on the convicted vendor list." Refer to Section 287.133, Florida Statutes.

INSTRUCTIONS TO BIDDERS
SECTION 1 - SPECIAL INSTRUCTIONS

I-1.01 GENERAL:

The proposed work is the Lois Pumping Station Driveway in the City of Tampa, as required for a complete project, as shown on the plans and detailed in the specifications. The work is located on land owned or controlled by the City of Tampa.

To be eligible to submit a proposal, a Bidder must hold the required and/or appropriate current license, certificate, or registration (e.g. DBPR license/certificate of authorization, etc.) in good standing at the time of receipt of Bids. **Per Section 489.131, Florida Statutes, Proposals submitted for the construction, improvement, remodeling, or repair of public projects must be accompanied by evidence that the Bidder holds the required and/or appropriate current certificate or registration, unless the work to be performed is exempt under Section 489.103, Florida Statutes.**

I-1.02 FORM PREPARATION AND PRESENTATION OF PROPOSALS: Replace the second sentence with the following: Submission of the entire specification book is not required.

I-1.03 ADDENDA – Section I-2.03 is replaced with the following: No interpretation of the meaning of the Plans, Specifications, or other Contract Documents will be made to any Bidder orally.

Every request for such interpretation must be in writing, addressed to the City of Tampa, Contract Administration Department, 306 E. Jackson St., 4th Floor, Tampa, Florida 33602 and then emailed to ContractAdministration@tampagov.net. To be given consideration, such request must be received at least seven (7) days prior to the date fixed for the opening of the Proposals. Any and all such interpretations and any supplemental instructions will be in the form of written addenda which, if issued, will be posted on DemandStar.Com and on the Department's web page, with notice given to all prospective bidders at the respective fax numbers or e-mail addresses furnished, for such purposes. Failure of any Bidder to receive any such addenda shall not relieve said Bidder from any obligation under his Proposal as submitted. All addenda so issued shall become part of the Contract Documents.

I-1.04 INSTRUCTIONS TO BIDDERS

SECTION 2 – GENERAL INSTRUCTIONS. Section I-2.07 SIGNATURE AND QUALIFICATIONS OF BIDDERS is replaced with the following:

Proposals must be signed in ink by the Bidder with signature in full. When firm is a Bidder, the Proposal shall be signed in the name of the firm by one or more partners. When a corporation is a bidder the officer signing shall set out the corporate name in full beneath which he shall sign his name and give the title of his office. The Proposal shall also bear the seal of the corporation attested by its secretary.

If the bidder referred to in Section I-2.07 is a corporation, it must submit; upon request, a copy of its filed Articles of Incorporation. In addition, if the bidder was incorporated in another state, it must establish that it is authorized to do business in the State of Florida. If the bidder is using a fictitious name, it must submit upon request, proof of registration of such name with the Clerk of the Circuit Court of the County where its principal place of business is. Failure to submit what is required is grounds to reject the bid of that bidder.

SECTION 2 – GENERAL INSTRUCTIONS. Section I-2.14 NONDISCRIMINATION IN EMPLOYMENT is changed to add the following to the end of the existing text:

The following provisions are hereby incorporated into any contract executed by or on behalf of the City. Contractor shall comply with the following Statement of Assurance: During the performance of the Contract, the Contractor assures the City, that the Contractor is in compliance with Title VII of the 1964 Civil Rights Act, as amended, the Florida Civil Rights Act of 1992, and the City of Tampa Code of Ordinances, Chapter 12, in that Firm/Contractor does not on the grounds of race, color, national origin, religion, sex, sexual orientation, gender identity or expression, age, disability, familial status, or marital status, discriminate in any form or manner against said Firm's/Contractor's employees or applicants for employment. Contractor understands and agrees that the Contract is conditioned upon the veracity of this Statement of Assurance, and that violation of this condition shall be considered a material breach of the Award/Contract. Furthermore, Contractor herein assures the City that said Contractor will comply with Title VI of the Civil Rights Act of 1964 when federal grant(s) is/are

INSTRUCTIONS TO BIDDERS
SECTION 1 - SPECIAL INSTRUCTIONS

involved. This Statement of Assurance shall be interpreted to include Vietnam-Era Veterans and Disabled Veterans within its protective range of applicability. Firm/Contractor further acknowledges and agrees to provide the City with all information and documentation that may be requested by the City from time to time regarding the solicitation, selection, treatment and payment of subcontractors, suppliers and vendors in connection with this Award/Contract. Firm/Contractor further acknowledges that it must comply with City of Tampa Code of Ordinances, Chapter 26.5, as enacted by Ordinance No. 2008-89.

I-1.05 TIME FOR COMPLETION:

The work shall be arranged to be completed in accordance with a progress schedule approved by the Construction Engineer.

The time for completion of this project, referred in Article 4.01 of the Agreement, shall be 270 consecutive calendar days. The period for performance shall start from the date indicated in the Notice To Proceed.

I-1.06 LIQUIDATED DAMAGES:

The amount of liquidated damages, referred to in Article 4.06 of the Agreement, for completion of this project shall be \$500 per calendar day.

I-1.07 BASIS OF AWARD OF CONTRACT:

The basis of award referred to in Item I-2.11 of Instructions to Bidders shall be the greatest amount of work, which can be accomplished within the funds available as budgeted. The award may be made on the basis of the total bid, base bid, alternates(s) if any, unit bids if any, or any combination thereof deemed to be in the best interest of the City.

Unless all bids are rejected, the award will be made within 90 days after opening proposals.

I-1.08 GROUND BREAKING CEREMONY:

Arrangement may be made by the City in coordination with the Contractor, for construction to commence with a Ground Breaking Ceremony. Details will be discussed at the pre-construction conference.

I-1.09 INSURANCE:

The insurance required for this project shall be as indicated on the attached and incorporated Special Instructions pages beginning with page INS-1 entitled CITY OF TAMPA INSURANCE REQUIREMENTS, which among other things requires the Contractor to provide a Certificate of Insurance to the City prior to commencing work. The City may from time to time use a third party vendor to manage its insurance certificates and related documentation which vendor may periodically initiate contact, requests for information, etc. on the City's behalf.

I-1.10 EQUAL BUSINESS OPPORTUNITY PROGRAM / SLBE / REQUIREMENTS

BIDDERS MUST SUBMIT COMPLETED FORMS MBD-10 AND MBD-20 WITH BIDS. BIDS SUBMITTED WITHOUT THE COMPLETED FORMS (INCLUDING SIGNATURES) WILL BE DEEMED NON-RESPONSIVE.

In accordance with the City of Tampa's Equal Business Opportunity Program, no Goal has been established for subcontracting with Small Local Business Enterprises, (SLBEs), certified by the City for this project.

INSTRUCTIONS TO BIDDERS
SECTION 1 - SPECIAL INSTRUCTIONS

SHELTERED MARKET for SLBEs or Underutilized WMBEs: This bid/proposal is a Sheltered Market solicitation for current City of Tampa certified Small Local Business Enterprises (SLBEs) and Underutilized Women/Minority Business Enterprises (WMBEs) identified on MBD Form-70 for "Construction". Only submissions from current certified SLBEs and Underutilized WMBEs on MBD Form-70 will be reviewed. To determine if your company is eligible as a City of Tampa Small Local Business Enterprise and/or Women/Minority Business Enterprise, please contact the Minority and Small Business Development Office at (813) 274-5512.

Bidders may explore opportunities for subcontracting with SLBEs by consulting the current directory of all certified SLBEs posted on the Minority Business Development Office web page.

DIVERSITY MANAGEMENT INITIATIVE, DMI, DATA REPORTING FORMS REQUIRED - Bidders must submit, with its bid, "DMI-Solicited" forms listing all subcontractors solicited and "DMI-Utilized" forms listing all subcontractors to be utilized. Supplemental forms, documentation, or information may be submitted at bid time or as requested by the City.

After an award, "DMI-Payments" forms are to be submitted with payment requests to report payments to subcontractors.

Bidders may visit the Minority Business Development Office's web page at TampaGov.net for other information about the SLBE program, FAQ's, and the latest SLBE directory of certified firms.

I-1.11 BID SECURITY:

Surety companies shall have a rating of not less than B+ Class VI as evaluated in the most recently circulated Best KeyRating Guide Property/Casualty.

I-1.12 PUBLIC CONSTRUCTION BOND:

The Bidder who is awarded the Contract will be required to furnish a Public Construction Bond upon the form provided herein, equal to 100 percent of the Contract price, such Bond to be issued and executed by (a) surety company(ies) acceptable to the City and licensed to underwrite contracts in the State of Florida. After execution of the Agreement and before commencing work, the Contractor must provide the City a certified copy of the officially recorded Bond.

I-1.13 AGREEMENT

SECTION 2 – POWERS OF THE CITY'S REPRESENTATIVES, new Article 2.05:

Add the following:

Article 2.05 CITY'S TERMINATION FOR CONVENIENCE:

The City may, at any time, terminate the Contract in whole or in part for the City's convenience and without cause. Termination by the City under this Article shall be by a notice of termination delivered to the Contractor, specify the extent of termination and the effective date.

Upon receipt of a notice of termination, the Contractor shall immediately, in accordance with instructions from the City, proceed with performance of the following duties regardless of delay in determining or adjusting amounts due under this Paragraph:

- (a) cease operations as specified in the notice;
- (b) place no further orders and enter into no further subcontracts for materials, labor, services or facilities except as necessary to complete continued portions of the Contract;
- (c) terminate all subcontracts and orders to the extent they relate to the Work terminated;
- (d) proceed to complete the performance of Work not terminated; and
- (e) take actions that may be necessary, or that the City may direct, for the protection and preservation of the terminated Work.

The amount to be paid to the Contractor by the City because of the termination shall consist of:

- (a) for costs related to work performed on the terminated portion of the Work prior to the effective date including termination costs relative to subcontracts that are properly chargeable to the terminated portion of the Work;

INSTRUCTIONS TO BIDDERS
SECTION 1 - SPECIAL INSTRUCTIONS

- (b) the reasonable costs of settlement of the Work terminated, including accounting, legal, clerical and other expenses reasonable necessary for the preparation of termination settlement proposals and supporting data; additional costs of termination and settlement of subcontracts excluding amounts of such settlements; and storage, transportation, and other costs incurred which are reasonably necessary for the preservation, protection or disposition of the terminated Work; and
- (c) a fair and reasonable profit on the completed Work unless the Contractor would have sustained a loss on the entire Contract had it been completed.

Allowance shall be made for payments previously made to the Contractor for the terminated portion of the Work, and claims which the City has against the Contractor under the Contract, and for the value of materials supplies, equipment or other items that are part of the costs of the Work to be disposed of by the Contractor.

SECTION 5 – SUBCONTRACTS AND ASSIGNMENTS, Article 5.01, Page A-7, last paragraph:
Change "...twenty-five (25) percent..." to "...fifty-one (51) percent..."

SECTION 8 – CONTRACTOR'S EMPLOYEES, Article 8.03, Page A-9, delete Article 8.03 in its entirety and replace with the following new article:

ARTICLE 8.03 EMPLOYMENT OPPORTUNITIES

The Contractor shall, in the performance of the work required to be done under this Contract, employ all workers without discrimination and must not maintain, provide or permit facilities that are segregated.

SECTION 10 – PAYMENTS, Article 10.05, Page A-10, 1st Paragraph, 1st Sentence:
Change "...fair value of the work done, and may apply for..." to "...fair value of the work done, and shall apply for..."

SECTION 11 – MISCELLANEOUS PROVISIONS, Article 11.02, Page A-12, 1st Paragraph, 2nd Sentence:
Delete the 2nd Sentence in its entirety and replace it with the following new 2nd Sentence:

Without limiting application of Article 11.07, below, whenever the Contractor is required or desires to use any design, device, material, or process covered by letters of patent or copyright, the Contractor shall indemnify, defend, and hold harmless the City Indemnified Parties (as defined below) from any and all Claims (as defined below) for infringement by reason of the use of any such patented design, device, tool, material, equipment, or process, to be performed under the Contract and damages which may be incurred by reason of such infringement at any time during the prosecution or after completion of the work.

SECTION 11 – MISCELLANEOUS PROVISIONS, Article 11.03, Page A-12:
Delete Article 11.03 in its entirety and replace with the following new article:

ARTICLE 11.03 INTENTIONALLY OMITTED.

SECTION 11 – MISCELLANEOUS PROVISIONS, Article 11.07, Page A-12:
Delete Article 11.07 in its entirety and replace with the following new article:

ARTICLE 11.07 INDEMNIFICATION PROVISIONS

Whenever there appears in this Agreement, or in the other Contact Documents made a part hereof, an indemnification provision within the purview of Chapter 725.06, Laws of Florida, the monetary limitation on the extent of the indemnification under each such provision shall be One Million Dollars or a sum equal to the total Contract price, whichever shall be the greater.

Contractor releases and agrees to defend, indemnify and hold harmless the City, its officers, elected and appointed officials, employees, and/or agents (collectively, "City Indemnified Parties") from and against any and all losses,

INSTRUCTIONS TO BIDDERS
SECTION 1 - SPECIAL INSTRUCTIONS

liabilities, damages, penalties, settlements, judgments, charges, or costs (including without limitation attorneys' fees, professional fees, or other expenses) of every kind and character arising out of any and all claims, liens, is entitled to indemnification hereunder. This obligation shall in no way be limited in any nature whatsoever by any limitation on the amount or type of Contractor's insurance coverage.

The parties agree that to the extent the written terms of this indemnification are deemed by a court of competent jurisdiction to be in conflict with any provisions of Florida law, in particular Sections 725.06 and 725.08, Florida Statutes, the written terms of this indemnification shall be deemed by any court of competent jurisdiction to be modified in such a manner as to be in fully and complete compliance with all such laws and to contain such limiting conditions or limitations of liability, or to not contain any unenforceable or prohibited term or terms, such that this indemnification shall be enforceable in accordance with and to the maximum extent permitted by Florida law.

The obligation of Contractor under this Article is absolute and unconditional; it is not conditioned in any way on any attempt by a City Indemnified Party to collect from an insurer any amount under a liability insurance policy, and is not subject to any set-off, defense, deduction, or counterclaim that the Contractor might have against the City Indemnified Party. The duty to defend hereunder is independent and separate from the duty to indemnify, and the duty to defend exists regardless of any ultimate liability of Contractor, the City, and any City Indemnified Party. The duty to defend arises immediately upon presentation of a Claim by any party and written notice of such Claim being provided to Contractor. Contractor's defense and indemnity obligations hereunder will survive the expiration or earlier termination of this Contract.

Contractor agrees and recognizes that the City Indemnified Parties shall not be held liable or responsible for any Claims which may result from any actions or omissions of Contractor in which the City Indemnified Parties participated either through providing data or advice and/or review or concurrence of Contractor's actions. In reviewing, approving or rejecting any submissions by Contractor or other acts of Contractor, the City in no way assumes or shares any responsibility or liability of Contractor or any tier of subcontractor/subconsultant/supplier, under this Contract.

In the event the law is construed to require a specific consideration for such indemnification, the parties agree that the sum of Ten Dollars and 00/100 (\$10.00), receipt of which is hereby acknowledged, is the specific consideration for such indemnification and the providing of such indemnification is deemed to be part of the specifications with respect to the services provided by Contractor.

SECTION 11 – MISCELLANEOUS PROVISIONS, Article 11.12, Page A-13:
Change Article 11.12 to add the following new language after existing text:

The City of Tampa is a public agency subject to Chapter 119, Florida Statutes. In accordance with Florida Statutes, 119.0701, Contractor agrees to comply with Florida's Public Records Law, including the following:

1. Contractor shall keep and maintain public records required by the City to perform the services under this Agreement;
2. Upon request by the City, provide the City with copies of the requested records, having redacted records in total on in part that are exempt from disclosure by law or allow the records to be inspected or copied within a reasonable time (with provision of a copy of such records to the City) on the same terms and conditions that the City would provide the records and at a cost that does not exceed that provided in Chapter 119, Florida Statutes, or as otherwise provided by law;
3. Ensure that records, in part or in total, that are exempt or that are confidential and exempt from disclosure requirements are not disclosed except as authorized by law for the duration of the Agreement term and following completion (or earlier termination) of the Agreement if Contractor does not transfer the records to the City;

INSTRUCTIONS TO BIDDERS
SECTION 1 - SPECIAL INSTRUCTIONS

4. Upon completion (or earlier termination) of the Agreement, Contractor shall within 30 days after such event either transfer to the City, at no cost, all public records in possession of the Contractor or keep and maintain the public records in compliance with Chapter 119, Florida Statutes. If Contractor transfers all public records to the City upon completion (or earlier termination) of the Agreement, Contractor shall destroy any duplicate records that are exempt or confidential and exempt from public records disclosure requirements. If Contractor keeps and maintains public records upon completion (or earlier termination) of the Agreement, Contractor shall meet all applicable requirements for retaining public records. All records stored electronically must be provided to the City in a format that is compatible with the information technology systems of the agency.

The failure of Contractor to comply with Chapter 119, Florida Statutes, and/or the provisions set forth in this Article shall be grounds for immediate unilateral termination of the Agreement by the City; the City shall also have the option to withhold compensation due Contractor until records are received as provided herein.

IF CONTRACTOR HAS QUESTIONS REGARDING THE APPLICATION OF CHAPTER 119, FLORIDA STATUTES, TO CONTRACTOR'S DUTY TO PROVIDE PUBLIC RECORDS RELATING TO THIS AGREEMENT, CONTACT THE CUSTODIAN OF PUBLIC RECORDS AT 813-274-8598, JIM.GREINER@TAMPAGOV.NET, AND CONTRACT ADMINISTRATION DEPARTMENT, TAMPA MUNICIPAL OFFICE BUILDING, 4TH FLOOR, 306 E. JACKSON ST. TAMPA, FLORIDA 33602.

I-1.14 Contractors must utilize the U.S. Department of Homeland Security's E-Verify Systems to verify the employment eligibility of all persons employed during the term of the Contract to perform employment duties within the State of Florida and all persons, including subcontractors, assigned by Contractor to perform work pursuant to the contract.

I-1.15 GENERAL PROVISIONS; G-2.02 Copies Furnished to Contractor: Replace the first paragraph with the following:

The Contractor shall acquire for its use copies of the plans and specifications as needed, which may be downloaded from the City's web site, at http://www.tampagov.net/dept_contract_administration/programs_and_services/construction_project_bidding/index.asp

Bidder as part of the solicitation process (and as Contractor if Bidder is successful) may hold, come into possession of, and/or generate certain building plans, blueprints, schematic drawings, including draft, preliminary, and final formats, which depict the internal layout and structural elements of a building, facility, or other structure owned or operated by the City or an agency (singularly or collectively "Exempt Plans"), which pursuant to Section 119.071(3), Florida Statutes, are exempt from Section 119.07(1), Florida Statutes and Section 24(a), Art. I of the Florida State Constitution. Contractor certifies it has read and is familiar the exemptions and obligations of Section 119.071(3), Florida Statutes; further that Contractor is and shall remain in compliance with same, including without limitation maintaining the exempt status of such Exempt Plans, for so long as any Exempt Plans are held by or otherwise in its possession.

I-1.16 PAYMENT DISPUTE RESOLUTION

Any dispute pertaining to pay requests must be presented to the City pursuant to Executive Order 2003-1.

I-1.17 SCRUTINIZED COMPANIES.

Section 287.135, Florida Statutes, prohibits agencies or local governmental entities from contracting with companies for goods or services of \$1,000,000 or more that are on either the Scrutinized Companies with Activities in Sudan List or the Scrutinized Companies with Activities in the Iran Petroleum Energy Sector List, created pursuant to Section 215.473, Florida Statutes, or is on the Scrutinized Companies that Boycott Israel List, created pursuant to Section 215.4725, Florida Statutes, (effective October 1, 2016), or is engaged in a boycott of Israel (effective October 1, 2016), or is engaged in business operations in Cuba or Syria. A company that is on either the Scrutinized Companies with Activities in Sudan List or the

INSTRUCTIONS TO BIDDERS
SECTION 1 - SPECIAL INSTRUCTIONS

Scrutinized Companies with Activities in the Iran Petroleum Energy Sector List, created pursuant to Section 215.473, Florida Statutes, or is on the Scrutinized Companies that Boycott Israel List, created pursuant to Section 215.4725, Florida Statutes, (effective October 1, 2016) or is engaged in a boycott of Israel (effective October 1, 2016) or is engaged in business operations in Cuba or Syria is ineligible to, and may not, bid on, submit a proposal for, or enter into or renew a contract with an agency or local governmental entity for goods or services of \$1,000,000 or more. Contractor certifies that it is not in violation of Section 287.135, Florida Statutes. For contracts \$1,000,000 and greater, if the City determines the Contractor submitted a false certification under Section 287.135(5) of the Florida Statutes, or has been placed on the Scrutinized Companies with Activities in the Sudan List or the Scrutinized Companies with Activities in the Iran Petroleum Energy Sector List, or is on the Scrutinized Companies that Boycott Israel List, created pursuant to Section 215.4725, Florida Statutes, (effective October 1, 2016), or is engaged in a boycott of Israel (effective October 1, 2016), or been engaged in business operations in Cuba or Syria, the City shall either terminate the Agreement after it has given the Contractor notice and an opportunity to demonstrate the City's determination of false certification was in error pursuant to Section 287.135(5)(a) of the Florida Statutes, or maintain the Agreement if the conditions of Section 287.135(4) of the Florida Statutes are met.

I-1.18 FLORIDA'S PUBLIC RECORDS LAW; DATA COLLECTION

Pursuant to Section 119.071(5)(a)2a, Florida Statutes, social security numbers shall only be collected from Bidders and/or Contractor by the City should such number be needed for identification, verification, and/or tax reporting purposes. To the extent Bidder and/or Contractor collects an individual's social security number in the course of acting on behalf of the City pursuant to the terms and conditions of its Proposal or, if awarded, the Agreement, Bidder and/or Contractor shall follow the requirements of Florida's Public Records Law.

[REMAINDER OF PAGE INTENTIONALLY LEFT BLANK]

INSTRUCTIONS TO BIDDERS

SECTION 2 GENERAL INSTRUCTIONS

I-2.01 BIDDER'S RESPONSIBILITY

Before submitting Proposals, Bidders shall carefully examine the entire site of the proposed work and adjacent premises and the various means of approach and access to the site, and make all necessary investigations to inform themselves thoroughly as to the facilities necessary for delivering, placing and operating the necessary construction equipment, and for delivering and handling materials at the site, and inform themselves thoroughly as to all difficulties involved in the completion of all the work in accordance with the Contract Documents.

Bidders must examine the Plans, Specifications, and other Contract Documents and shall exercise their own judgment as to the nature and amount of the whole of the work to be done, and for the bid prices must assume all risk of variance, by whomsoever made, in any computation or statement of amounts or quantities necessary to complete the work in strict compliance with the Contract Documents.

Elevations of the ground are shown on the Plans and are believed to be reasonably correct, but are not guaranteed to be absolutely so and are presented only as an approximation. Bidders shall satisfy themselves as to the correctness of all elevations.

The City may have acquired, for its own use, certain information relating to the character of materials, earth formations, probable profiles of the ground, conditions below ground, and water surfaces to be encountered at the site of the proposed work. This information, if it exists, is on file at the offices of the Department of Public Works and Bidders will be permitted to see and examine this information for whatever value they consider it worth. However, this information is not guaranteed, and Bidders should satisfy themselves by making borings or test pits, or by such other methods as they may prefer, as to the character, location, and amounts of water, peat, clay, sand, quicksand, gravel, boulders, conglomerate, rock, gas or other material to be encountered or work to be performed.

Various underground and overhead structures and utilities are shown on the plans. The location and dimensions of such structures and utilities, where given, are believed to be reasonably correct, but do not purport to be absolutely so. These structures and utilities are plotted on the Plans for the information of the Bidders, but information so given is not to be construed as a representation or assurance that such structures will be found or encountered as plotted, or that such information is complete or accurate.

I-2.02 FORM, PREPARATION AND PRESENTATION OF PROPOSALS

Each Proposal shall be submitted upon the Proposal Form and in accordance with the instructions included herein. The Proposal Form must not be detached herefrom. All blank spaces for bid prices must be filled in, in both words and figures, with the unit or lump sum prices, or both, for which the Proposal is made. The computed total price for each unit price Contract Item shall be determined by multiplying the estimated quantity of the item, as set forth in the Proposal Form, by the corresponding unit price bid for such item. The resulting product shall be entered in the appropriate blank space under the column headed "Computed Total Price for Item". The lump sum price bid for each lump sum price Contract Item shall also be entered in the column headed "Computed Total Price for Item". If a Proposal contains any omissions, erasures, alterations, additions, or items not called for in the itemized Proposal, or contains irregularities of any kind, such may constitute sufficient cause for rejection of the Proposal. In case of any discrepancy in the unit price or amount bid for any item in the Proposal, the price as expressed in written words will govern. In no case is the Agreement Form to be filled out or signed by the Bidder.

In the case of certain jobs bid Lump Sum a "Schedule of Unit Prices" must be filled out as an attachment to the Lump Sum proposal. These prices may be used as a guide for the negotiation of change orders, at the City's option.

The proposal must be signed and certified and be presented on the prescribed form in a sealed envelope on/or before the time and at the place stated in the Notice of Bidders, endorsed with the name of the person, firm or corporation presenting it, the date of presentation, and the title of the work for which the Proposal is made.

Unless the apparent low bidder is now engaged in or has recently completed contract work for the City of Tampa, he, if requested, shall furnish to the City, after the opening of bids and prior to award, a summary statement of record of construction experience over the past three (3) years with proper supporting evidence, and, if required by the City, shall also furnish a list of equipment and other facilities pertinent to and available for the proper execution of the proposed work, and a statement of financial resources to the extent necessary to establish ability to carry on the proposed work. The City may make further investigations as considered necessary with respect to responsibility of the Bidder to whom it appears may be awarded the Contract.

If forwarded by mail, the sealed envelope containing the Proposal, endorsed as directed above, must be enclosed in another envelope addressed as specified in the Notice to Bidders and sent by registered mail.

I-2.03 ADDENDA AND INTERPRETATIONS

No interpretation of the meaning of the Plans, Specifications, or other Contract Documents will be made to any Bidder orally.

Every request for such interpretation must be in writing, addressed to the Contract Administration Department, Tampa Municipal Office Building, 4th Floor North, City Hall Plaza, Tampa, Florida 33602. To be given consideration, such request must be received at least seven (7) days prior to the date fixed for the opening of the Proposals. Any and all such interpretations and any supplemental instructions will be in the form of written addenda which, if issued, will be sent by certified mail, with return receipt requested, to all prospective bidders at the respective addresses furnished, for such purposes, not later than three (3) working days prior to the date fixed for the opening of the Proposals, and if requested, a copy will be delivered to the prospective bidder's representative. Failure of any Bidder to receive any such addenda shall not relieve said Bidder from any obligation under his Proposal as submitted. All addenda so issued shall become part of the Contract Documents.

I-2.04 BID SECURITY

Each Proposal must be accompanied by a certified or cashier's check issued by a solvent bank or trust company and payable at sight to the City of Tampa, in compliance with Section 255.051 Florida Statutes, or a Bid Bond upon the form provided herein, in an amount of not less than five percent of the sum of the computed total amount of the Bidder's Proposal as a guarantee that if the Proposal is accepted, the Bidder will execute and fill in the proposed Contract and Public Construction Bond within twenty (20) days after notice of award of the Contract. Certified checks shall have all necessary documentary revenue stamps attached if required by law. Surety on Bid Bonds shall be a duly authorized surety company authorized to do business in the State of Florida, and all such Bonds shall be issued or countersigned by a local resident producing agent, and satisfactory evidence of the authority of the person or persons executing such Bond to Execute the same shall be submitted with the Bond. Bid Bonds shall be issued by a surety company acceptable to the City.

Within ten (10) days after the opening of Proposals, the bid security of all but the three lowest Bidders will be returned. The bid security of the remaining two Bidders whose Proposals are not accepted will be

returned within ten (10) days after the execution of the Contract, or, if no such Contract has been executed, within ninety (90) days after the date of opening Proposals. The bid security of the Bidder whose Proposal is accepted will be returned only after he has duly executed the Contract and furnished the required Public Construction Bond and insurance.

Should it be necessary for the City to retain the bid security and said bid security is in the form of checks, the checks of these Bidders will be returned if replaced by Bid Bonds in an amount equal to the amount of the checks of such Bidders in such form and issued by a surety company acceptable to the City.

A Bidder may withdraw his Proposal before the time fixed for the opening of Proposals, without prejudice to himself, by communicating his purpose, in writing, to the Mayor and City Council, and when his communication is received, the Proposal will be handed to him or his authorized agent unopened. No Bidder may withdraw his Proposal within ninety (90) days after the day of opening Proposals.

The Bidder whose Proposal is accepted shall enter into a written contract, upon the Agreement form included herein, for the performance of the work and furnish the required Public Construction Bond within twenty (20) days after written notice by the City of Award of Contract has been served on such Bidder personally or after receipt of the written notice by registered mail to such Bidder at the address given in his Proposal.

If the Bidder to whom a Contract is awarded refuses or neglects to execute it or fails to furnish the required Public Construction Bond within twenty (20) days after receipt by him of the Notice of Award of Contract, the amount of his bid security shall be forfeited and shall be retained by the City as liquidated damages, and not as a penalty, it being now agreed that said sum is a fair estimate of the amount of damages that the City will sustain in case said Bidder fails to enter into a Contract and furnish the required Public Construction Bond. If a Bid Bond was furnished, the full amount of the Bond shall become due and payable as liquidated damages caused by such failure. The full amount of the bid security shall be forfeited as liquidated damages without consideration of the fact that an award may be less than the full amount of the Bidder's Proposal, excepting that the award shall be within the conditions of said Proposal relating to the basis of consideration for an award. No plea of mistake in the bid or misunderstanding of the conditions of forfeiture shall be available to the Bidder for the recovery of his deposit or as a defense to any action based upon the neglect or refusal to execute a contract.

I-2.05 LAWS AND REGULATIONS

The Bidder who is awarded the Contract must comply with all laws of the State of Florida, and all applicable Ordinances of the City of Tampa respecting labor and compensation and with all other statutes, ordinances, rules and regulations applicable and having the force of law.

I-2.06 PUBLIC CONSTRUCTION BOND

The Bidder who is awarded the Contract will be required to furnish a Public Construction Bond upon the form provided herein, equal to 100 percent of the Contract price, such Bond to be executed by a surety company acceptable to the City of Tampa and licensed to underwrite contracts in the State of Florida. Surety companies shall have a rating of not less than: B+ Class VI as evaluated in the most recently circulated BEST'S KEY RATING GUIDE PROPERTY-LIABILITY.

I-2.07 SIGNATURE AND QUALIFICATIONS OF BIDDERS

Proposals must be signed in ink by the Bidder with signature in full. When a firm is a Bidder, the Proposal shall be signed in the name of the firm by one or more of the partners. When a corporation is a Bidder the officer signing shall set out the corporate name in full beneath which he shall sign his name and give the title of his office. The Proposal shall also bear the seal of the corporation attested by its secretary. Anyone signing the Proposal as agent must file with it legal evidence of his authority to do so.

Bidders who are nonresident corporations shall furnish to the City a

duly certified copy of their permit to transact business in the State of Florida, signed by the Secretary of State, within ten days of the notice to do so. Such notice will be given to Bidders who are nonresident corporations, to whom it appears an award will be made, and the copy of the permit must be filed with the City before the award will be made. Failure to promptly submit this evidence of qualification to do business in the State of Florida may be basis for rejection of the Proposal.

I-2.08 REJECTION OF PROPOSALS

The City reserves the right to reject any Proposal if investigation of the Bidder fails to satisfy the City that such Bidder is properly qualified to carry out the obligations and to complete the work contemplated therein. Any or all Proposals will be rejected if there is reason to believe that collusion exists among Bidders. Proposals will be considered irregular and may be rejected if they show serious omissions, alterations in form, additions not called for, conditions or unauthorized alternates, or irregularities of any kind. The City reserves the right to reject any or all Proposals and to waive such technical errors as may be deemed best for the interests of the City.

I-2.09 QUANTITIES ESTIMATED ONLY

The estimate of quantities of the various items of work and materials, if set forth in the Proposal Form, is approximate only and is given solely to be used as a uniform basis for the comparison of Proposals.

The quantities actually required to complete the Contract work may be less or more than so estimated, and if awarded a Contract for the work specified, the Contractor agrees that he will not make any claim for damages or for loss of profits because of a difference between the quantities of the various classes of work assumed for comparison of Proposals and quantities of work actually performed. The City further reserves the right to vary the quantities in any amount.

I-2.10 COMPARISON OF PROPOSALS

Except jobs bid on a "One Lump Sum" basis, proposals will be compared on the basis of a total computed price arrived at by taking the sum of the estimated quantity of each item and the corresponding unit price of each item, and including any lump sum prices on individual items.

The computed total prices for individual Contract Items and the total computed price for the entire Contract, as entered by the Bidder in the Proposal Form, are for convenience only and are subject to correction in the tabulation and computation of the Proposals.

I-2.11 BASIS OF AWARD

The Contract will be awarded, if at all, to the lowest responsible Bidder or Bidders, as determined by the City and by the terms and conditions of the Contract Documents. Unless all bids are rejected, the award will be made within ninety (90) days after the opening of Proposals. The successful Bidder will be required to possess, or obtain, a valid City Occupational License.

I-2.12 INSURANCE REQUIRED

The successful Bidder and his subcontractors will be required to procure and pay for insurance covering the work in accordance with the provisions of Article 6.02 of the Agreement as indicated on special instructions pages beginning with INS-1.

I-2.13 NO ASSIGNMENT OF BID

No Bidder shall assign his bid or any rights thereunder.

I-2.14 NONDISCRIMINATION IN EMPLOYMENT

Contracts for work under this Proposal will obligate the contractors and subcontractors not to discriminate in employment practices.

Bidders must, if requested, submit with their initial bid a signed statement as to whether they have previously performed work subject to the President's Executive Order Nos. 11246 and 11375.

Bidders must, if requested, submit a compliance report concerning their employment practices and policies in order to maintain their eligibility to receive the award of the Contract.

Successful Bidders must, if requested, submit a list of all subcontractors who will perform work on the project and written,

signed statement from authorized agents of the labor pools with which they will or may deal for employees on the work together with supporting information to the effect that said labor pools practices and policies are in conformity with Executive Order No. 11246 and that said labor pools will affirmatively cooperate in or offer no hindrance to the recruitment, employment and equal treatment of employees seeking employment and performing work under the Contract, or a certification as to what efforts have been made to secure such statements when such agents or labor pools have failed or refused to furnish them prior to the award of the Contract.

I-2.15 LABOR STANDARDS

The Bidder's attention is directed to the Contract Provisions of the Labor Standards for federally assisted projects which may be attached to and made a part of the Agreement.

I-2.16 NOTICE TO LABOR UNIONS

If applicable, the successful Bidder will be required to provide Labor Unions and other organizations of workers a completed copy of the form entitled "Notice to Labor Unions or Other Organizations of Workers", and such form may be made a part of the Agreement.

I-2.17 NOTICE TO PROSPECTIVE FEDERALLY-ASSISTED CONSTRUCTION CONTRACTORS

A Certification of Nonsegregated Facilities, as required by the May 9, 1967, Order (32 F.R. 7439, May 19, 1967) on Elimination of Segregated Facilities, by the Secretary of Labor, must be submitted to said Secretary prior to the award of a federally-assisted construction and Contract exceeding \$10,000 which is not exempt from the provisions of the Equal Opportunity Clause. The form of certification may be bound herein following the form of Bid Bond.

Contractors receiving federally-assisted construction Contract awards exceeding \$10,000 which are not exempt from the provisions of the Equal Opportunity Clause will be required to provide for the forwarding of the following notice to prospective subcontractor for supplies and construction contracts where the subcontracts exceed \$10,000 and are not exempt from the provisions of the Equal Opportunity Clause:

NOTICE TO PROSPECTIVE SUBCONTRACTORS OF REQUIREMENT FOR CERTIFICATIONS OF NONSEGREGATED FACILITIES

"A Certification of Nonsegregated Facilities, as required by the May 9, 1967, Order (32 F.R. 7439, May 19, 1967) on Elimination of Segregated Facilities, by the Secretary of Labor, must be submitted prior to the award of a subcontract exceeding \$10,000 which is not exempt from the provisions of the Equal Opportunity Clause."

"Contractors receiving subcontract awards exceeding \$10,000 which are not exempt from the provisions of the Equal Opportunity Clause will be required to provide from the forwarding of this notice to prospective subcontractors for supplies and construction contracts where the subcontracts exceed \$10,000 and are not exempt from the provisions of the Equal Opportunity Clause."

The United States requires a pre-award conference if a proposed construction contract exceeds one million dollars to determine if the the prospective contractor is in compliance with the Equal Employment Opportunity requirements of Executive Order 11246 of September 24, 1965. In such instances, a meeting may be scheduled at which the prospective contractor must specify what affirmative action he has taken or proposed to take to assure equal employment opportunity which must be approved by the United States before award of the contract will be authorized.

Bidders must be prepared to submit an Equal Employment Opportunity (EEO) plan at a pre-award conference. The plan must include bidding opportunities offered by the Bidder to minority subcontractors.

On October 13, 1971, President Nixon issued Executive Order 11246 emphasizing the government's commitment to the promotion of minority business enterprise. Accordingly, the United States is firmly

committed to the utilization of available resources to support this important program. U.S. agencies are most interested in realizing minority participation on the subject. Achieving equal employment opportunity compliance is required through Executive Order 11246. WE cannot emphasize too strongly that minority subcontractors be extended subcontractors bidding opportunities as but one step in your affirmative action policy.

Due to the importance of this contract, U.S. Agencies may conduct an EEO Conference prior to the award of the Contract. It is suggested that the responsive Bidder confirm the minority subcontractors he contacted for bids or quotations in his EEO plan submitted at the conference.

I-2.18 EEO AFFIRMATIVE ACTION REQUIREMENTS

By the submission of a Proposal, each Bidder acknowledges that he understands and will agree to be bound by the equal opportunity requirements of Federal regulations which shall be applicable throughout the performance of work under any contract awarded pursuant to solicitation. Each Bidder agrees that if awarded a contract, he will similarly bind contractually each subcontractor. In policies, each Bidder further understands and agrees that if awarded a contract, he must engage in Affirmative Action directed to promoting and ensuring equal employment opportunity in the work force used under the contract (and he must require contractually the same effort of all subcontractors whose subcontracts exceed \$100,000). The Bidder understands and agrees that "Affirmative Action" as used herein shall constitute a good faith effort to achieve and maintain minority employment in each trade in the on-site work force used on the project. ***** END of SECTION *****

CITY OF TAMPA INSURANCE REQUIREMENTS

Prior to commencing any work or services or taking occupancy under that certain written agreement or award (for purposes of this document, Agreement) between the City of Tampa, Florida (City) and Firm/Awardee/Contractor/Consultant/Lessee/non-City party, etc. (for purposes of this document, Firm) to which this document is attached and incorporated as an Exhibit or otherwise, and continuing during the term of said Agreement (or longer if the Agreement and/or this document so requires), Firm shall provide, pay for, and maintain insurance against claims for injuries to persons (including death) or damages to property which may arise from or in connection with the performance of the Agreement (including without limitation occupancy and/or use of certain property/premises) by Firm, its agents, representatives, employees, suppliers, subtenants, or subcontractors (which term includes sub-consultants, as applicable) of any tier subject to the terms and conditions of this document. Firm's maintenance of insurance coverage as required herein is a material element of the Agreement and the failure to maintain or renew coverage or provide evidence of same (defined to include without limitation Firm's affirmative duty to provide from time to time upon City's request certificates of insurance, complete and certified copies of Firm's insurance policies, forms, and endorsements, information on the amount of claims payments or reserves chargeable to the aggregate amount of coverage(s) whether during the term of the Agreement or after as may be requested by the City in response to an issue or potential claim arising out of or related to the Agreement to which Firm's insurance obligations hereunder may apply or possibly help mitigate) may be treated as a material breach of the Agreement. Should at any time Firm not maintain the insurance coverages required, City at its sole option (but without any obligation or waiver of its rights) may (i) terminate the Agreement or (ii) purchase such coverages as City deems necessary to protect the itself (charging Firm for same) and at City's option suspending Firm's performance until such coverage is in place. If Firm does not reimburse City for such costs within 10 days after demand, in addition to any other rights, City shall also have the right to offset such costs from amounts due Firm under any agreement with the City. All provisions intended to survive or to be performed subsequent to the expiration or termination of the Agreement shall survive, including without limitation Firm's obligation to maintain or renew coverage, provide evidence of coverage and certified copies of policies, etc. upon City's request and/or in response to a potential claim, litigation, etc.

The City reserves the right from time to time to modify or waive any or all of these insurance requirements (or to reject policies) based on the specific nature of goods/services to be provided, nature of the risk, prior experience, insurer, coverage, financial condition, failure to operate legally, or other special circumstances. If Firm maintains broader coverage and/or higher limits than the minimums shown herein, the City requires and shall be entitled to such broader coverage and/or higher limits maintained by Firm. Any available insurance proceeds in excess of the specified minimum limits of insurance and coverage shall be available to the City. No representation is made that the minimum insurance requirements are sufficient to cover Firm's interests, liabilities, or obligations. Required insurance shall not limit Firm's liability.

Firm acknowledges and agrees Firm and not the City is the party in the best position to determine applicability (e.g. "IF APPLICABLE"), confirm, and/or verify its insurance coverage. Acceptance by the City, or by any of its employees, representatives, agents, etc. of certificates or other documentation of insurance or policies pursuant to the terms of this document and the Agreement evidencing insurance coverages and limits does not constitute approval or agreement that the insurance requirements have been met or that coverages or policies are in compliance. Furthermore, receipt, acceptance, and/or approval of certificates or other documentation of insurance or policies or copies of policies by the City, or by any of its employees, representatives, agents, etc., which indicate less coverage than required does not constitute a waiver of Firm's obligation to fulfill these insurance requirements.

MINIMUM SCOPE AND LIMIT OF INSURANCE ¹

A. Commercial General Liability (CGL) Insurance on the most current Insurance Services Office (ISO) Form CG 00 01 or its equivalent on an "occurrence" basis (Modified Occurrence or Claims Made forms are not acceptable without prior written consent of the City). Coverage must be provided to cover liability contemplated by the Agreement including without limitation premises and operations, independent contractors, contractual liability, products and completed operations, property damage, bodily, personal and advertising injury, contractual liability, explosion, collapse, underground coverages, personal injury liability, death, employees-as-insureds. Products and completed operations liability coverage maintained for at least 3 years after completion of work. Limits shall not be less than \$1M per occurrence and \$2M general aggregate for Agreements valued at \$2M or less; if valued over \$2M, a general aggregate limit that equals or exceeds the Agreement's value. If a general aggregate limit applies, it shall apply separately to the project/location (ISO CG 25 03 or 25 04 or equivalent). **(ALWAYS APPLICABLE)**

B. Automobile Liability (AL) Insurance in accordance with Florida law, as to the ownership, maintenance, and use of all owned, non-owned, leased, or hired vehicles. AL insurance shall not be less than: (a) \$500,000 combined single limit each occurrence bodily injury and property damage for Agreements valued at \$100,000 or less or (b) \$1M combined single limit each occurrence bodily injury and property damage for Agreements valued over \$100,000. If transportation of hazardous material involved, the MCS-90 endorsement (or equivalent). **(ALWAYS APPLICABLE)**

C. Worker's Compensation (WC) & Employer's Liability Insurance for all employees engaged under the Agreement, Worker's Compensation as required by Florida law. Employer's Liability with minimum limits of (a) \$500,000 bodily injury by accident and each accident, bodily injury by disease policy limit, and bodily injury by disease each employee for Agreements valued at \$100,000 and under or (b) \$1M bodily injury by accident and each accident, bodily injury by disease policy limit, and bodily injury by disease each for all other Agreements. **(ALWAYS APPLICABLE)**

D. Excess (Umbrella) Liability Insurance for Agreements valued at \$2M or more, at least \$4M per occurrence in excess of underlying limits and no more restrictive than underlying coverage for all work performed by Firm. May also compensate for a deficiency in CGL, AL, or WC. **(ALWAYS APPLICABLE)**

E. Builder's Risk Insurance for property loss exposure associated with construction/renovation/additions to buildings or structures, including materials or fixtures to be incorporated. Must be "All Risk" form with limits of no less than the project's completed value, have no coinsurance penalties, eliminate the "occupancy clause", cover Firm (together with its contractors, subcontractors of every tier, and suppliers), and name City as a Loss Payee. **(IF APPLICABLE)**

F. Installation Floater coverage for property (usually highly valued equipment or materials such as compressors, generators, etc.) during its installation. Coverage must be "All Risk" including installation and transit for no less than 100% of the installed replacement cost value. **(IF APPLICABLE)**

G. Architects & Engineers Liability/ Professional Liability (E&O)/ Contractors Professional Liability (CPrL)/ Medical Malpractice Insurance where Agreement involves Florida-regulated professional services (e.g. architect, engineer, design-builder, CM, accountant, appraiser, investment banker medical professional) at any tier, whether employed or independent, vicarious design liability exposure (e.g. construction means & methods, design supervision), value engineering, constructability assessments/reviews, BIM process, and/or performance specifications. Limits of at least \$1M per occurrence and \$2M aggregate; deletion of design/ build liability exclusions, as applicable, and maintained for at least 3 years after completion of work/services and City's acceptance of same. **(IF APPLICABLE)**

H. Railroad Protective Liability (RPL) Insurance for construction within 50ft of operated railroad track(s) or where affects any railroad bridge, trestle, tunnel, track(s) roadbed, or over/under pass. Subject to involved rail road's approval prior to commencement of work. **(IF APPLICABLE)**.

I. Pollution and/or Asbestos Legal Liability Insurance where Agreement involves asbestos and/or environmental hazards/contamination risks (defined broadly, e.g. lead, mold, bacteria, fuel storage, underground work, cleanup (owned or non-owned sites), pollutant generation/transportation, marine/natural resource damage, contamination claim, restitution, business interruption, mold, fungus, lead-based paint, 3rd party claims/removal, etc.), with limits of at least \$1M per occurrence and \$2M aggregate, maintained for at least 3 years after Agreement completion. **(IF APPLICABLE)**

J. Cyber Liability Insurance where Agreement involves portals allowing access to obtain, use, or store data; managed dedicated servers; cloud hosting services; software/hardware; programming; and/or other IT services

¹ "M" indicates million(s), for example \$1M is \$1,000,000

and products are involved. Limits of not less than \$2M per occurrence and \$2M aggregate. Coverage sufficiently broad to respond to duties and obligations undertaken by Firm, and shall include, but not be limited to, claims involving infringement of intellectual property/copyright, trademark, trade dress, invasion of privacy violations, damage to or destruction of electronic information, information theft, release of confidential and/or private information, alteration of electronic information, extortion, virus transmission, and network security. Coverage, as applicable and with sufficient limits to respond, for breach response costs, regulatory fines and penalties, credit monitoring expenses. **(IF APPLICABLE)**

K. Drone/UAV Liability Insurance where Agreements involves unmanned aerial vehicles/drones. Coverage to include products and completed operations, property damage, bodily injury with limits no less than \$1M per occurrence, and \$2M aggregate; may be provided by CGL endorsement subject to City's prior written approval. **(IF APPLICABLE)**

L. Longshore & Harbor Workers' Compensation Act/Jones Act for work being conducted near, above, or on "navigable waters" for not less than the above Employer's Liability Insurance limit. **(IF APPLICABLE)**

M. Garagekeeper/Hangerkeeper/Marina Operator Legal Liability Insurance and/or Hull/P&I Insurance where parking lot, valet, dealership, garage services, towing, etc. and/or operation of a hangar, marina, or air

plane/ship repairer, providing safe berth, air/watercraft storage/docking (on land/ in water), fueling, tours, charters, ferries, dredges, tugs, mooring, towing, boat/aircraft equipment/repair/alteration/maintenance, etc.; coverage against liability for damage to vehicles air/watercraft, their machinery in Firm's care, custody, or control both private & commercial. Limits at least equal to greater of \$1M, value of max number of vehicles that may be in Firm's custody, or of most costly object in Firm's custody. **(IF APPLICABLE)**

N. Property Insurance and Interruption of Business (IOB) Insurance where premises, building, structure, or improved real property is leased, licensed, or otherwise occupied by Firm. Property Insurance against all risks of loss to any occupant/tenant improvements at full replacement cost with no coinsurance penalty, including fire, water, leak damage, and flood, as applicable, vandalism and malicious mischief endorsements. IOB by which minimum monthly rent will be paid to City for up to 1 year if premises are destroyed, rendered inaccessible or untenable, including disruption of utilities, water, or telecommunications. **(IF APPLICABLE)**

O. Liquor Liability/Host Liquor Liability where Firm directly or indirectly provides alcoholic beverages, limits of at least \$1M per occurrence and \$1M aggregate. **(IF APPLICABLE)**

P. Educators Legal Liability Insurance where day care, after school program, recreational activities, etc. limits per G above. **(IF APPLICABLE)**

ADDITIONAL REQUIREMENTS

ACCEPTABILITY OF INSURERS - Insurance is to be placed with insurers admitted in the State of Florida and who have a current A.M. Best rating of no less than **A-:VII** or, if not rated by A.M. Best, as otherwise approved by the City in advance and in writing.

ADDITIONAL INSURED - **City, its elected officials, departments, officers, officials, employees, and volunteers together with, as applicable, any associated lender of the City shall be covered as additional insureds on all liability coverage** (e.g. CGL, AL, and Excess (Umbrella) Liability) as to liability arising out of work or operations performed by or on behalf of Firm including materials, parts, or equipment furnished in connection with such work or operations and automobiles owned, leased, hired, or borrowed by or on behalf of Firm. Coverage can be provided in the form of an endorsement to Firm's insurance (at least as broad as ISO Form CG 20 10 11 85 or **both** CG 10 20, CG 20 26, CG 20 33, or CG 20 38 **and** CG 20 37 if later revisions used).

CANCELLATION/NON-RENEWAL - Each insurance policy shall provide that at least 30 days written notice must be given to City of any cancellation, intent to non-renew, or material reduction in coverage (except aggregate liability limits) and at least 10 days' notice for non-payment of premium. Firm shall also have an independent duty to notify City in like manner, within 5 business days of Firm's receipt from its insurer of any notices of same. If any policy's aggregate limit is reduced, Firm shall directly take steps to have it reinstated. Notice and proof of renewal/continued coverage/certifications, etc. shall be sent to the City's notice (or Award contact) address as stated in the Agreement with a copy to the following:

- Contract Administration Department, 306 E Jackson St, Tampa, FL 33602 Purchasing Department, 306 E Jackson Street, Tampa, FL 33602
 Other: _____

CERTIFICATE OF INSURANCE (COI) - to be provided to City by insurance carrier prior to Firm beginning any work/services or taking occupancy and, if the insurance expires prior to completion of the work or services or Agreement term (as may be extended), a renewal COI at least 30 days before expiration to the above address(es). COIs shall specifically identify the Agreement and its subject (project, lease, etc.), shall be sufficiently comprehensive to insure City (named as additional insured) and Firm and to certify that coverage extends to subcontractors' acts or omissions, and as to permit the City to determine the required coverages are in place without the responsibility of examining individual policies. **Certificate Holder must be The City of Tampa, Florida.**

CLAIMS MADE - If any liability insurance is issued on a claims made form, Firm agrees to maintain such coverage uninterrupted for at least 3 years following completion and acceptance of the work either through purchase of an extended reporting provision or purchase of successive renewals. The Retroactive Date must be shown and be a date not later than the earlier of the Agreement date or the date performance/occupancy began thereunder.

DEDUCTIBLES/ SELF-INSURED RETENTIONS (SIR) - must be disclosed to City and, if over \$500,000, approved by the City in advance and in writing, including at City's option being guaranteed, reduced, or eliminated (additionally if a SIR provides a financial guarantee guaranteeing payment of losses and related investigations, claim administration, and defense expenses). Firm shall be fully responsible for any deductible or SIR (without limiting the foregoing a policy with a SIR shall provide or be endorsed to provide that the SIR may be satisfied by either the City or named insured). In the event of loss which would have been covered but for a deductible or SIR, City may withhold from any payment due Firm, under any agreement with the City, an amount equal to same to cover such loss should full recovery not be obtained under the policy.

PERFORMANCE - All insurance policies shall be fully performable in Hillsborough County, Florida (the County), and construed in accordance with Florida law. Further, all insurance policies must expressly state that the insurance company will accept service of process in the County and that the exclusive venue for any action concerning any matter under those policies shall be in the appropriate state court of the County.

PRIMARY POLICIES - Firm's insurance coverage shall be primary insurance coverage at least as broad as ISO CG 20 01 04 13 as to the City, its elected officials, departments, officers, employees, and volunteers. Any insurance or self-insurance maintained by the City, its elected officials, departments, officers, employees, and volunteers shall be excess of the Firm's insurance and shall not contribute with it.

SUBCONTRACTORS/INDEPENDENT ASSOCIATES/CONSULTANTS/SUBTENANTS/SUBLICENSEE - **Firm shall require and verify that all such entities maintain insurance meeting all requirements stated herein with the City as an additional insured** by endorsement (ISO FORM CG 20 38, or broader) or otherwise include such entities within Firm's insurance policies. Upon City's request, Firm shall furnish complete and certified copies of copies of such entities' insurance policies, forms, and endorsements.

SUBCONTRACTOR DEFAULT INSURANCE, CONTROLLED INSURANCE PROGRAM, WRAP-UP. Use requires express prior written consent of City Risk Manager.

UNAVAILABILITY - To the fullest extent permitted by law, if Firm is out of business or otherwise unavailable at the time a claim is presented to City, Firm hereby assigns to the City all of its right, title and interest (but not any liabilities or obligations) under any applicable policies of insurance.

WAIVER OF SUBROGATION - With regard to any policy of insurance that would pay third party losses, Firm hereby grants City a waiver of any right to subrogation which any insurer of Firm may acquire against the City by virtue of the payment of any loss under such insurance. Firm agrees to obtain any endorsement that may be necessary to affect such waiver, but this provision shall apply to such policies regardless.

WAIVER/RELEASE AGREEMENT - Where Firm has a defined group of persons who might be exposed to harm (e.g. participants in an athletic event/program, volunteers) any waiver or release agreement used by Firm whereby such persons (and their parent/guardian as applicable) discharge Firm from claims and liabilities, shall include the City, its elected officials, departments, officers, officials, employees, and volunteers to the same extent as Firm.

Procurement Guidelines To Implement Minority & Small Business Participation

Underutilized WMBE Primes by Industry Category

FORMAL PROCUREMENT	Construction	Construction-Related	Professional	Non-Professional	Goods
	Black	Asian	Black	Black	Black
	Hispanic	Native Am.	Hispanic	Asian	Hispanic
	Native Am.	Woman	Asian	Native Am.	Asian
	Woman		Native Am.		Native Am.
			Woman		Woman

Underutilized WMBE Sub-Contractors / Sub-Consultants

SUB WORK	Construction	Construction-Related	Professional	Non-Professional	Goods
	Black	Black	Black	Black	Black
		Asian	Hispanic	Asian	Asian
		Native Am.	Asian	Native Am.	Native Am.
		Woman	Native Am.		Woman
			Woman		

Policy

The Guidelines apply to formal procurements and solicitations. WMBE participation will be narrowly-tailored.

Index

- Black = Black/African-American Business Enterprise
- Hispanic = Hispanic Business Enterprise
- Asian = Asian Business Enterprise
- Native Am. = Native American Business Enterprise
- Woman = Woman Business Enterprise (Caucasian)

Industry Categories

Construction is defined as: new construction, renovation, restoration, maintenance of public improvements and underground utilities.

Construction-Related Services are defined as: architecture, professional engineering, landscape architecture, design build, construction management services, or registered surveying and mapping.

Professional Services are defined as: attorney, accountant, medical doctor, veterinarian, miscellaneous consultant, etc.

Non-Professional Services are defined as: lawn maintenance, painting, janitorial, printing, hauling, security guard, etc.

Goods are defined as: all supplies, materials, pipes, equipment, machinery, appliances, and other commodities.

MBD Form-70

SOLICITATION FOR SUBCONTRACTOR QUOTES

From:
OUR COMPANY NAME:
TELEPHONE NUMBER:
ADDRESS:
FAX NUMBER:
E-MAIL ADDRESS:

To Subcontractor:

Our firm is in the process of preparing a bid for a **City of Tampa Contract**. Please accept this notice as our request for quotes for the scope of work identified below. Please respond to this request by filling in the information below and returning via e-mail or fax to the address or number provided. Please contact us if you need any assistance in obtaining bonding, lines of credit, insurance, assistance in obtaining necessary equipment, supplies, materials, participation in a City-sponsored mentor-protégé program, or if you have any questions.

Plans and Specs for this project are posted at:
http://www.tampagov.net/dept_contract_administration/programs_and_services/construction_project_bidding/

CONTRACT NO.:
CONTRACT NAME:
CITY'S BID OPENING DATE:
DEADLINE FOR YOUR SUBCONTRACTOR BID OR RESPONSE:
SPECIFIC SCOPE OF WORK:

Please complete and submit with your subcontract bid or response:

YOUR FIRM'S NAME:
MAILING ADDRESS:
CITY:
STATE:
ZIP:
FAX NUMBER:
E-MAIL ADDRESS:

Yes, my company is interested in quoting this project for the following items of work:

No, my company will not quote this project for the following reason(s):

(Sample Suggested Sub Solicitation 3-9-9 Tampa MBDO)

PROPOSAL

To the Mayor and City Council of the City of Tampa, Florida:

Legal Name of Bidder: _____

Bidder's Fictitious Name, *if applicable*: _____

Bidder is a/an: Individual Partnership* Joint Venture* LLC Corp. Other:

Bidder is organized under the laws of: State of Florida Other:

Bidder Mailing Address: _____

Bidder's Federal Employee Identification No. (FEI/EIN): _____

Bidder's License No.: _____ Bidder's FDOS (SUNBIZ) Doc. No.: _____

(See Ch. 489, FS; use entity's, individual's only if applicable)

Bidder Contact Name**: _____ Email: _____ Phone: (____) _____

Bidder's own initial application for employment has criminal history screening practices similar in nature to the practices contained in Chapter 12, Article VI, City of Tampa Code (*Responses, whether "Yes" or "No", are for informational purposes only and will not be used as a basis of award or denial, nor as a basis for any protest*): Yes No

The below named person, appearing before the undersigned authority and after being first duly sworn, for him/herself and on behalf of the entity submitting this Proposal does hereby affirm and declare as follows:

- (1) He/She is of lawful age and is authorized to act on behalf of Bidder (the individual, partnership, corporation, entity, etc. submitting this Proposal) and that all statements made in this document are true and correct to the best of my knowledge.
- (2) If Bidder is operating under a fictitious name, Bidder has currently complied with any and all laws and procedures governing the operation of businesses under fictitious names in the State of Florida
- (3) No person or entity other than Bidder has any interest in this Proposal or in the Contract proposed to be entered into.
- (4) This Proposal is made without any understanding, agreement, or connection with any person or entity making Proposal for the same purposes, and is in all respects fair and without collusion or fraud.
- (5) Bidder is not in arrears to the City of Tampa, upon debt or contract, and is not a defaulter, as surety or otherwise, upon any obligation to the City of Tampa.
- (6) That no officer or employee or person whose salary is payable in whole or in part from the City Treasury is, shall be or become interested, directly or indirectly, as a contracting party, partner, stockholder, surety or otherwise, in this Proposal, or in the performance of the Contract, or in the supplies, materials, or equipment and work or labor to which it relates, or in any portion of the profits thereof.
- (7) Bidder has carefully examined and fully understands the Solicitation and has full knowledge of the scope, nature, and quality of the work to be performed; furthermore, Bidder has carefully examined the site of the work and that, from his own investigations, he has satisfied himself as to the nature and location of the work, the character, quality, and quantity of materials and the kinds and extent of equipment and other facilities needed for the performance of the work, the general and local conditions and all difficulties to be encountered, and all other items which may, in any way, affect the work or its performance.
- (8) Bidder (including its principals) has | has NOT been debarred or suspended from contracting with a public entity.
- (9) Bidder has | has NOT implemented a drug-free workplace program that meets the requirements of Section 287.087, Florida Statutes.
- (10) Bidder has carefully examined and fully understands all the component parts of the Contract Documents and agrees Bidder will execute the Contract, provide the required Public Construction Bond, and will fully perform the work in strict accordance with the terms of the Contract and Contract Documents therein referred to for the following prices, to wit:

* If a Partnership or Joint Venture, attach Partnership or Joint Venture Agreement.

** Someone the City may contact with questions/correspondence regarding this Solicitation and/or permits.

Contract Item No.	Estimated Quantity	Description and Price in Words	Computed Total Price for Item in Figures
BASE BID	LS	The work includes the furnishing of all labor, equipment, and material to add an asphalt access driveway and retention pond as specified in construction plans, any contingency allowances as stated in SP-60, and with all associated work required for a complete project in accordance with the Contract Documents.	
		_____ _____ dollars and _____ cents	
		(BASE BID) LS	\$ _____

Computed Total Price in Words: _____
 _____ dollars and _____ cents.

Computed Total Price in Figures: \$ _____

Bidder acknowledges that the following addenda have been received and that the changes covered by the addendum(s) have been taken into account in this proposal: #1 ____ #2 ____ #3 ____ #4 ____ #5 ____ #6 ____ #7 ____ #8 ____.

Bidder acknowledges the requirements of the City of Tampa's Equal Business Opportunity Program.

Bidder acknowledges that it is aware of Florida's Trench Safety Act (Sections 553.60-553.64, Florida Statutes), and agrees that Bidder together with any involved subcontractors will comply with all applicable trench safety standards. Bidder further acknowledges that included in the various items of this Proposal and the total bid price (as applicable) are costs for complying with the Trench Safety Act. Bidder further identifies the costs and methods summarized below:

	Trench Safety Measure (Description)	Unit of Measure (LF, SY)	Unit Quantity	Unit Cost	Extended Cost
A.	_____	_____	_____	_____	_____
B.	_____	_____	_____	_____	_____
C.	_____	_____	_____	_____	_____
Total Cost: \$					_____

Accompanying this Proposal is a certified check, cashier's check or Tampa Bid Bond (form included herein must be used) for at least five percent (5%) of the total amount of the Proposal which check shall become the property of the City, or which bond shall become forthwith due and payable to the City, if this Proposal shall be accepted by the City and the Bidder shall fail to enter into a legally binding contract with and to furnish the required Public Construction Bond to the City within twenty (20) days after the date of its receipt of written Notice of Award by the City so to do.

FAILURE TO COMPLETE THE ABOVE MAY RESULT IN THE PROPOSAL BEING DECLARED NON-RESPONSIVE.

[SEAL] Name of Bidder: _____
 Authorized Signature: _____
 Signer's Printed Name: _____
 Signer's Title: _____

STATE OF _____
 COUNTY OF _____

For an entity: The forgoing instrument was sworn (or affirmed) before me this ____ day of _____, 20____ by _____ as _____ of _____, a/n Partnership Joint Venture LLC Corp Other: _____, on behalf of such entity. Such individual is personally known to me or produced a/n _____ state driver's license as identification.

For an individual: The forgoing instrument was sworn (or affirmed) before me this ____ day of _____, 20____ by _____, who is personally known to me or produced a/n _____ state driver's license as identification.

[NOTARY SEAL] _____
 Notary Public, State of _____
 Notary Printed Name: _____
 Commission No.: _____
 My Commission Expires: _____



Good Faith Effort Compliance Plan Guidelines

for Women/Minority Business Enterprise/Small Local Business Enterprise Participation
City of Tampa - Equal Business Opportunity Program
(MBD Form 50 – detailed instructions on page 2 of 2)

Contract Name _____ Bid Date _____

Bidder/Proposer _____

Signature _____ Date _____

Name _____ Title _____

The Compliance Plan with attachments is a true account of Good Faith Efforts (GFE) made to achieve the participation goals as specified for Women/Minority Business Enterprises/Small Local Business Enterprises (WMBE/SLBE) on the referenced contract:

The WMBE/SLBE participation **Goal is Met or Exceeded**. See DMI Forms 10 and 20 which accurately report all subcontractors solicited and all subcontractors to-be-utilized.

The WMBE/SLBE participation Goal is **Not Achieved**. The following list is an overview of the baseline GFE action steps already performed. Furthermore, it is understood that these GFE requirements are weighted in the compliance evaluation based on the veracity and demonstrable degree of documentation provided with the bid/proposal:

(Check applicable boxes below. Must enclose supporting documents accordingly with remarks)

- (1) Solicited through reasonable and available means the interest of WMBE/SLBEs that have the capability to perform the work of the contract. The Bidder or Proposer must solicit this interest within sufficient time to allow the WMBE/SLBEs to respond. The Bidder or Proposer must take appropriate steps to follow up initial solicitations with interested WMBE/SLBEs. See DMI report forms for subcontractors solicited. See enclosed supplemental data on solicitation efforts. Qualifying Remarks:
- (2) Provided interested WMBE/SLBEs with adequate, specific scope information about the plans, specifications, and requirements of the contract, including addenda, in a timely manner to assist them in responding to the requested-scope identified by bidder/proposer for the solicitation. See enclosed actual solicitations used. Qualifying Remarks:
- (3) Negotiated in good faith with interested WMBE/SLBEs that have submitted bids (e.g. adjusted quantities or scale). Documentation of negotiation must include the names, addresses, and telephone numbers of WMBE/SLBEs that were solicited; the date of each such solicitation; a description of the information provided regarding the plans and specifications for the work selected for subcontracting; and evidence as to why agreements could not be reached with WMBE/SLBEs to perform the work. Additional costs involved in soliciting and using subcontractors is not a sufficient reason for a bidder/proposer's failure to meet goals or achieve participation, as long as such costs are reasonable. Bidders are not required to accept excessive quotes in order to meet the goal. DMI Utilized Forms for sub-(contractor/consultant) reflect genuine negotiations This project is an RFO/RFP in nature and negotiations are limited to clarifications of scope/specifications and qualifications. See enclosed documentation. Qualifying Remarks:
- (4) Not rejecting WMBE/SLBEs as being unqualified without justification based on a thorough investigation of their capabilities. The WMBE/SLBEs standing within its industry, membership in specific groups, organizations / associations and political or social affiliations are not legitimate causes for rejecting or not soliciting bids to meet the goals. Not applicable. See attached justification for rejection of a subcontractor's bid or proposal. Qualifying Remarks:
- (5) Made scope(s) of work available to WMBE/SLBE subcontractors and suppliers; and, segmented portions of the work or material consistent with the available WMBE/SLBE subcontractors and suppliers, so as to facilitate meeting the goal. Sub-Contractors were allowed to bid on their own choice of work or trade without restriction to a pre-determined portion. See enclosed comments. Qualifying Remarks:
- (6) Made good faith efforts, despite the ability or desire of Bidder/Proposer to perform the work of a contract with its own forces/organization. A Bidder/Proposer who desires to self-perform the work of a contract must demonstrate good faith efforts if the goal has not been met. Sub-Contractors were not prohibited from submitting bids/proposals and were solicited on work typically self-performed by the prime. Qualifying Remarks:
- (7) Segmented portions of the work to be performed by WMBE/SLBEs in order to increase the likelihood that the goals will be met. This includes, where appropriate, breaking out contract work items into economically feasible units (quantities/scale) to facilitate WMBE/SLBE participation, even when the Bidder/Proposer might otherwise prefer to perform these work items with its own forces. Sub-Contractors were allowed to bid on their own choice of work or trade without restriction to a pre-determined portion. Sub-Contractors were not prohibited from submitting bids/proposals and were solicited on work typically self-performed by the prime. See enclosed comments. Qualifying Remarks:
- (8) Made efforts to assist interested WMBE/SLBEs in obtaining bonding, lines of credit, or insurance as required by the city or contractor. See enclosed documentation on initiatives undertaken and methods to accomplish. Qualifying Remarks:
- (9) Made efforts to assist interested WMBE/SLBEs in obtaining necessary equipment, supplies, materials, or related assistance or services, including participation in an acceptable mentor-protégé program. See enclosed documentation of initiatives and/or agreements. Qualifying Remarks:
- (10) Effectively used the services of the City and other organizations that provide assistance in the recruitment and placement of WMBE/SLBEs. See enclosed documentation. The following services were used:

Note: Provide any unsolicited information that will support the Bid/RFP Compliance Evaluation. Named Documents Are:



Participation Plan: Guidance for Complying with Good Faith Efforts Outreach
(page 2 of 2)

1. All firms on the WMBE/SLBE Goal Setting List must be solicited and documentation provided for email, fax, letters, phone calls, and other methods of outreach/communication with the listed firms. The DMI Solicited and DMI-Utilized forms must be completed for all firms solicited or utilized. Other opportunities for subcontracting may be explored by consulting the City of Tampa MBD Office and/or researching the on-line Diversity Management Business System Directory for Tampa certified WMBE/SLBE firms.
2. Solicitation of WMBE/SLBEs, via written or electronic notification, should provide specific information on the services needed, where plans can be reviewed and assistance offered in obtaining these, if required. Solicitations should be sent a minimum of a week (i.e. 5 business days or more) before the bid/proposal date. Actual copies of the bidder's solicitation containing their scope specific instructions should be provided.
3. With any quotes received, a follow-up should be made when needed to confirm detail scope of work. For any WMBE/SLBE low quotes rejected, an explanation shall be provided detailing negotiation efforts.
4. If a low bid WMBE/SLBE is rejected or deemed unqualified the contractor must provide an explanation and supporting documentation for this decision.
5. Prime shall break down portions of work into economical feasible opportunities for subcontracting. The WMBE/SLBE directory may be useful in identifying additional subcontracting opportunities and firms not listed in the "WMBE/SLBE Goal Setting Firms List."
6. Contractor shall not preclude WMBE/SLBEs from bidding on any part of work, even if the Contractor may desire to self-perform the work.
7. Contractor shall avoid relying solely on subcontracting out work-scope where WMBE/SLBE availability is not sufficient to attain the pre-determined subcontract goal set for the Bid or when targeted sub-consultant participation is stated within the RFP/RFQ.
8. In its solicitations, the Bidder should offer assistance to WMBE/SLBEs in obtaining bonding, insurance, et cetera, if required of subcontractors by the City or Prime Contractor.
9. In its solicitation, the Bidder should offer assistance in obtaining equipment for a specific job to WMBE/SLBEs, if needed.
10. Contractor should use the services offered by such agencies as the City of Tampa Minority and Small Business Development Office, Hillsborough County Entrepreneur Collaborative Center, Hillsborough County Economic Development Department's MBE/SBE Program and the NAACP Empowerment Center to name a few for the recruitment and placement of WMBEs/SLBEs.



Failure to Complete, Sign and Submit Both Forms 10 & 20 SHALL render the Bid or Proposal Non-Responsive

**Page 1 of 4 – DMI Solicited/Utilized Schedules
City of Tampa – Schedule of **All Solicited** Sub-(Contractors/Consultants/Suppliers)
(FORM MBD-10)**

Contract No.: _____ Contract Name: _____
 Company Name: _____ Address: _____
 Federal ID: _____ Phone: _____ Fax: _____ Email: _____

Check applicable box(es). Detailed Instructions for completing this form are on page 2 of 4.

- No Firms were contacted or solicited for this contract.
- No Firms were contacted because: _____
- See attached list of additional Firms solicited and all supplemental information (List must comply to this form)
Note: Form MBD-10 must list ALL subcontractors solicited including Non-minority/small businesses

NIGP Code Categories: Buildings = 909, General = 912, Heavy = 913, Trades = 914, Architects = 906, Engineers & Surveyors = 925, Supplier = 912-77

S = SLBE W=WMBE O = Neither	Company Name Address Phone, Fax, Email	Type of Ownership (F=Female M=Male) BF BM = African Am. HF HM = Hispanic AF AM = Asian Am. NF NM = Native Am. CF CM = Caucasian	Trade or Services NIGP Code (listed above)	Contact Method L=Letter F=Fax E=Email P=Phone	Quote or Response Received Y/N

Failure to Complete, Sign and Submit
this form with your Bid or Proposal
Shall render the Bid Non-Responsive
(Do Not Modify This Form)

It is hereby certified that the information provided is an accurate and true account of contacts and solicitations for sub-contracting opportunities on this contract.

Signed: _____ Name/Title: _____ Date: _____

**Failure to Complete, Sign and Submit Both Forms 10 & 20 SHALL render the Bid or Proposal Non-Responsive
Forms must be included with Bid / Proposal**



Instructions for completing The Sub-(Contractors/Consultants/ Suppliers) Solicited Form (Form MBD-10)

This form must be submitted with all bids or proposals. All subcontractors (regardless of ownership or size) solicited and subcontractors from whom unsolicited quotations were received must be included on this form. The instructions that follow correspond to the headings on the form required to be completed. Note: Ability or desire to self-perform all work shall not exempt the prime from Good Faith Efforts to achieve participation.

- **Contract No.** This is the number assigned by the City of Tampa for the bid or proposal.
- **Contract Name.** This is the name of the contract assigned by the City of Tampa for the bid or proposal.
- **Contractor Name.** The name of your business and/or doing business as (dba) if applicable.
- **Address.** The physical address of your business.
- **Federal ID, FIN.** A number assigned to your business for tax reporting purposes.
- **Phone.** Telephone number to contact business.
- **Fax.** Fax number for business.
- **Email.** Provide email address for electronic correspondence.
- **No Firms were contacted or solicited for this contract.** Checking the box indicates that a pre-determined Subcontract Goal or Participation Plan Requirement was not set by the City resulting in your business not using subcontractors and will self-perform all work. If during the performance of the contract you employ subcontractors, the City must pre-approve subcontractors. Use of the “Sub-(Contractors/Consultants/Suppliers) Payments” form (MBD Form-30) must be submitted with every pay application and invoice. Note: Certified **SLBE or WMBE firms** bidding as Primes **are not exempt** from outreach and solicitation of subcontractors.
- **No Firms were contacted because.** Provide brief explanation why no firms were contacted or solicited.
- **See attached documents.** Check box, if after you have completed the DMI Form in its entirety, you need more space to list additional firms and/or if you have supplemental information/documentation relating to the form. All DMI data not submitted on the MBD Form-10 must be in the same format and have all requested data from MBD Form-10 included.

The following instructions are for information of any and all subcontractors solicited.

- **“S” = SLBE, “W” = WMBE.** Enter “S” for firms Certified by the City as Small Local Business Enterprises and/or “W” for firms Certified by the City as either Women/Minority Business Enterprise; **“O” = Non-certified others.**
- **Federal ID, FIN.** A number assigned to a business for tax reporting purposes. This information is critical in proper identification and payment of the contractor/subcontractor.
- **Company Name, Address, Phone & Fax.** Provide company information for verification of payments.
- **Type of Ownership.** Indicate the Ethnicity and Gender of the owner of the subcontracting business.
- **Trade, Services, or Materials** indicate the trade, service, or materials provided by the subcontractor. NIGP codes aka “National Institute of Governmental Purchasing” are listed at top section of document.
- **Contact Method L=letter, F=fax, E=Email, P=Phone.** Indicate with letter the method(s) of soliciting for bid.
- **Quote or Resp. (response) Rec’d (received) Y/N.** Indicate “Y” Yes if you received a quotation or if you received a response to your solicitation. Indicate “N” No if you received no response to your solicitation from the subcontractor. Must keep records: log, ledger, documentation, etc. that can validate/verify.

If additional information is required or you have questions, please contact the Equal Business Opportunity Program - Minority and Small Business Development Office at (813) 274-5522.



Failure to Complete, Sign and Submit Both Forms 10 & 20 SHALL render the Bid or Proposal Non-Responsive

Page 3 of 4 – DMI Solicited/Utilized Schedules
City of Tampa – Schedule of All To-Be-Utilized Sub-(Contractors/Consultants/Suppliers)
(FORM MBD-20)

Contract No.: _____ Contract Name: _____
Company Name: _____ Address: _____
Federal ID: _____ Phone: _____ Fax: _____ Email: _____

Check applicable box(es). Detailed Instructions for completing this form are on page 4 of 4.

See attached list of additional Firms Utilized and all supplemental information (List must comply to this form)

Note: Form MBD-20 must list ALL subcontractors To-Be-Utilized including Non-minority/small businesses

No Subcontracting/consulting (of any kind) will be performed on this contract.

No Firms are listed to be utilized because: _____

NIGP Code General Categories: Buildings = 909, General = 912, Heavy = 913, Trades = 914, Architects = 906, Engineers & Surveyors = 925, Supplier = 912-77

Enter "S" for firms Certified as Small Local Business Enterprises, "W" for firms Certified as Women/Minority Business Enterprise, "O" for Other Non-Certified

S = SLBE W=WMBE O =Neither	Company Name Address Phone, Fax, Email	Type of Ownership (F=Female M=Male) BF BM = African Am. HF HM = Hispanic Am. AF AM = Asian Am. NF NM = Native Am. CF CM = Caucasian	Trade, Services, or Materials NIGP Code Listed above	\$ Amount of Quote. Letter of Intent (LOI) if available	Percent of Scope or Contract %

Failure to Complete, Sign and Submit
this form with your Bid or Proposal
Shall render the Bid Non-Responsive.
(Do Not Modify This Form)

Total ALL Subcontract / Supplier Utilization \$ _____
Total SLBE Utilization \$ _____
Total WMBE Utilization \$ _____
Percent SLBE Utilization of Total Bid/Proposal Amt. _____% Percent WMBE Utilization of Total Bid/Proposal Amt. _____%

It is hereby certified that the following information is a true and accurate account of utilization for sub-contracting opportunities on this Contract.

Signed: _____ Name/Title: _____ Date: _____

Failure to Complete, Sign and Submit Both Forms 10 & 20 SHALL render the Bid or Proposal Non-Responsive
Forms must be included with Bid / Proposal



Page 4 of 4 DMI – Solicited/Utilized Instructions for completing The Sub-(Contractors/Consultants/ Suppliers) to be Utilized Form (Form MBD-20)

This form must be submitted with all bids or proposals. All subcontractors (regardless of ownership or size) projected to be utilized must be included on this form. Note: Ability or desire to self-perform all work shall not exempt the prime from Good Faith Efforts to achieve participation.

Contract No. This is the number assigned by the City of Tampa for the bid or proposal.

- **Contract Name.** This is the name of the contract assigned by the City of Tampa for the bid or proposal.
- **Contractor Name.** The name of your business and/or doing business as (dba) if applicable.
- **Address.** The physical address of your business.
- **Federal ID.** FIN. A number assigned to your business for tax reporting purposes.
- **Phone.** Telephone number to contact business.
- **Fax.** Fax number for business.
- **Email.** Provide email address for electronic correspondence.
- **No Subcontracting/consulting (of any kind) will be performed on this contract.** Checking box indicates your business will not use subcontractors when no Subcontract Goal or Participation Plan Requirement was set by the City, but will self-perform all work. When subcontractors are utilized during the performance of the contract, the “Sub-(Contractors/Consultants/Suppliers) Payments” form (MBD Form-30) must be submitted with every pay application and invoice. Note: certified **SLBE or WMBE firms** bidding as Primes **are not exempt** from outreach and solicitation of subcontractors, including completion and submitting Form-10 and Form-20.
- **No Firms listed To-Be-Utilized.** Check box; provide brief explanation why no firms were retained when a goal or participation plan requirement was set on the contract. Note: mandatory compliance with Good Faith Effort outreach (GFECP) requirements applies (MBD Form-50) and supporting documentation must accompany the bid.
- **See attached documents.** Check box, if after completing the DMI Form in its entirety, you need more space to list additional firms and/or if you have supplemental information/documentation relating to the scope/value/percent utilization of subcontractors. Reproduce copies of MBD-20 and attach. All data not submitted on duplicate forms must be in the same format and content as specified in these instructions.

The following instructions are for information of Any and All subcontractors To Be Utilized.

- **Federal ID.** FIN. A number assigned to a business for tax reporting purposes. This information is critical in proper identification of the subcontractor.
- **“S” = SLBE, “W” = WMBE.** Enter “S” for firms Certified by the City as Small Local Business Enterprises and/or “W” for firms Certified by the City as Women/Minority Business Enterprise; **“O” = Non-certified others.**
- **Company Name, Address, Phone & Fax.** Provide company information for verification of payments.
- **Type of Ownership.** Indicate the Ethnicity and Gender of the owner of the subcontracting business.
- **Trade, Services, or Materials (NIGP code if Known)** Indicate the trade, service, or material provided by the subcontractor. Abbreviated list of NIGP is available at <http://www.tampagov.net/mbd> “Information Resources”.
- **Amount of Quote, Letters of Intent** (required for both SLBEs and WMBEs).
- **Percent of Work/Contract.** Indicate the percent of the total contract price the subcontract(s) represent. For CCNA only (i.e. Consultant A/E Services) you must indicate subcontracts as percent of total scope/contract.
- **Total Subcontract/Supplier Utilization.** – Provide total dollar amount of all subcontractors/suppliers projected to be used for the contract. (Dollar amounts may be optional in CCNA depending on solicitation format).
- **Total SLBE Utilization.** Provide total dollar amount for all projected SLBE subcontractors/Suppliers used for this contract. (Dollar amounts may be optional in CCNA proposals depending on the solicitation format).
- **Total WMBE Utilization.** Provide total dollar amount for all projected WMBE subcontractors/Suppliers used for this contract. (Dollar amounts may be optional in CCNA proposals depending on the solicitation format).
- **Percent SLBE Utilization.** Total amount allocated to SLBEs divided by the total bid/proposal amount.
- **Percent WMBE Utilization.** Total amount allocated to WMBEs divided by the total bid/proposal amount.

If additional information is required or you have questions, please contact the Equal Business Opportunity Program - Minority and Small Business Development Office at (813) 274-5522.

TAMPA BID BOND
Contract 17-C-00018; Lois Pumping Station Driveway

KNOW ALL MEN BY THESE PRESENTS, that we, _____

_____ (hereinafter called the Principal) and _____

(hereinafter called the Surety) a Corporation chartered and existing under the laws of the State of _____, with its principal offices in the City of _____, and authorized to do business in the State of Florida, are held and firmly bound unto the City of Tampa, a Municipal Corporation of Hillsborough County, Florida, in the full and just sum of 5% of the amount of the (Bid) (Proposal) good and lawful money of the United States of America, to be paid upon demand of the City of Tampa, Florida, to which payment will and truly to be made we bind ourselves, our heirs, executors, administrators, successors, and assigns, jointly and severally and firmly these presents.

WHEREAS, the Principal is about to submit, or has submitted to the City of Tampa, Florida, a Proposal for the construction of certain facilities for the City designated Contract 17-C-00018, Lois Pumping Station Driveway.

WHEREAS, the Principal desires to file this Bond in accordance with law, in lieu of a certified Bidder's check otherwise required to accompany this Proposal.

NOW, THEREFORE: The conditions of this obligation are such that if the Proposal be accepted, the Principal shall, within twenty (20) days after the date of receipt of written Notice of Award, execute a contract in accordance with the Proposal and upon the terms, conditions and price set forth therein, in the form and manner required by the City of Tampa, Florida and execute a sufficient and satisfactory Public Construction Bond payable to the City of Tampa, Florida in an amount of one hundred percent (100%) of the total contract price, in form and with security satisfactory to said City, then this Bid Bond obligation is to be void; otherwise to be and remain in full force and virtue in law, and the Surety shall, upon failure of the Principal to comply with any or all of the foregoing requirements within the time specified above, immediately pay to the aforesaid City, upon demand, the amount thereof, in good and lawful money of the United States of America, not as a penalty, but as liquidated damages.

IN TESTIMONY THEREOF, the Principal and Surety have caused these presents to be duly signed and sealed this _____ day of _____, 20____.

Principal

BY _____

TITLE _____

BY _____

TITLE _____

(SEAL)

Producing Agent

Producing Agent's Address

Name of Agency

The addition of such phrases as "not to exceed" or like import shall render the (Bid) (Proposal) non-responsive.

AGREEMENT

For furnishing all labor, materials and equipment, together with all work incidental thereto, necessary and required for the performance of the work for the construction of Contract 17-C-00018 in accordance with your Proposal dated _____, amounting to a total of \$_____ as completed in accordance with subsections I-2.09 and I-2.10 of the Instruction to Bidders.

THIS AGREEMENT, made and entered into in triplicate, this ____ day of _____, 20____, between the City of Tampa, Florida, hereinafter called the City, and hereinafter called the Contractor.

WITNESSETH that, in consideration of the mutual stipulations, agreements, and covenants herein contained, the parties hereto have agreed and hereby agree with each other, the Party of the First Part for itself, its successors and assigns, and the Party of the Second Part for itself, or himself, or themselves, and its successors and assigns, or his or their executors, administrators and assigns, as follows:

Contract 17-C-00018; Lois Pumping Station Driveway, shall include, but not be limited to, furnishing all labor, materials and equipment to add an asphalt access driveway and retention pond as specified in construction plans with all associated work required for a complete project in accordance with the Contract Documents.

Contract Documents referred to in Article 1.01 of this Agreement also includes this volume, applicable standard drawings, the plans and any provisions referred to whether actually attached or not.

TAMPA AGREEMENT

SECTION 1 GENERAL

ARTICLE 1.01 THE CONTRACT

Except for titles, subtitles, headings, running headlines, and tables of contents (all of which are printed herein merely for convenience), the following, except for such portions thereof as may be specifically excluded, constitute the Contract:

The Notice to Bidders;
The Instructions to Bidders, including Special Instructions and General Instructions;
The Proposal;
The Bid Bond;
The Certification of Nonsegregated Facilities;
The Notice of Award;
The Agreement;
The Performance Bond;
The Notice To Proceed;
The Specifications, including the General Provisions, the Workmanship and Materials, the Specific Provisions or the Contract Items
The Plans;
All Supplementary Drawings Issued after award of the Contract;
All Addenda issued by the City prior to the receipt of proposals;
All provisions required by law to be inserted in this Contract, whether actually inserted or not.

ARTICLE 1.02 DEFINITIONS

The following words and terms, or pronouns used in their stead, shall, wherever they appear in this Contract, be construed as follows, unless different meaning is clear from the context:

(a)"City" shall mean the City of Tampa, Florida, represented by its Mayor and City Council, Party of the First Part, or such other City official as shall be duly empowered to act for the City on matters relating to this Contract.

(b)"Contractor" shall mean the Party of the Second Part hereto, whether corporation, firm or individual, or any combination thereof, and its, their, or his successors, personal representatives, executors, administrators, and assigns, and any person, firm or corporation who or which shall at any time be substituted in the place of the Party of the Second Part under this Contract.

(c)"Engineer" shall mean the Director of the Department or his duly authorized representative.

(d)"Consultant" shall mean the engineering or architectural firm or individual employed by the City to consult with and advise the City in the construction of the project.

(e)"Surety" shall mean any person, firm or corporation that has executed as Surety the Contractor's Performance Bond securing the performance of this Contract.

(f)"The Work" shall mean everything expressly or implied required to be furnished and done by the Contractor under the Contract, and shall include both Contract Work

and Extra Work.

(g)"Contract Work" shall mean everything expressly or implied required to be furnished and done by the Contractor by any one or more of the Contract parts referred to in Article 1.01 hereof, except Extra Work, as hereinafter defined; it being understood that, in case of any inconsistency in or between any part or parts of this Contract, the Engineer shall determine which shall prevail.

(h)"Contract" or "Contract Documents" shall mean each of the various part of the Contract referred to in Article 1.01 hereof, both as a whole and severally.

(i)"Extra Work" shall mean work other than that required either expressly or implied by the contract in its present form.

(j)"Plans" shall mean only those drawings specifically referred to as such in these documents, or in any Addendum. Drawings issued after the execution of the Contract to explain further, or to illustrate, or to show changes in the work, will be known as "Supplementary Drawings" and shall be binding upon the Contractor with the same force as the Plans.

(k)"Specifications" shall mean all of the directions, requirements, and standards of performance applying to the work, as hereinafter detailed and designated as such, or which may be issued in an addendum.

(l)"Addendum or Addenda" shall mean the additional contract provisions issued in writing prior to the receipt of bids.

(m)"Notice" shall mean written notice. Notice shall be served upon the Contractor, either personally or by leaving the said notice at his residence or with any employee found on the work, or addressed to the Contractor at the residence or place of business given in his proposal and deposited in a postpaid wrapper in any post office box regularly maintained by the United States Post Office.

(n)"Project" shall mean the entire improvement package or related work. The "project" may consist of several different, but related, contracts.

(o)"Site" shall mean, and be limited to, the area upon or in which the Contractor's operations are carried on and such other appropriate areas as may be designed as such by the Engineer.

(p)"Subcontractor" shall mean any person, firm, or corporation, other than employees of the Contractor, who or which contracts with the Contractor to furnish, or actually furnishes labor, or labor and materials, or labor and equipment or labor, materials, and equipment at the site.

(q)Whenever in the Contract the words "directed", "required", "permitted", "ordered", "designated", "prescribed", and words of like import are used, they shall imply the direction, requirement, permission, order, designation, or prescription of the Engineer; and "approved", "acceptable", "satisfactory", "in the judgement of", and words of like import shall mean approved by, or acceptable to, or satisfactory to, or in the judgment of the Engineer.

(r)Whenever in the Contract the word "day" is used, it shall mean calendar day.

(s)"Final Acceptance" shall mean acceptance of the

work as evidenced by an official resolution of the City. Such acceptance shall be deemed to have taken place only if and when an approving resolution has been adopted by the City Council. The final acceptance shall be signed only after the City has assured itself by tests, inspection, or otherwise, that all of the provisions of the Contract have been carried out to its satisfaction.

(t)"Eastern Standard Time" shall be construed as the time being observed in the City on the day proposals are received or other documents issued or signed.

SECTION 2 POWERS OF THE CITY'S REPRESENTATIVES

ARTICLE 2.01 THE ENGINEER

It is covenanted and agreed that the Engineer, in addition to those matters elsewhere herein expressly made subject to his determination, direction, or approval, shall have the power, subject to such express provisions and limitations herein contained as are not in conflict herewith, and subject to review by the Mayor and City Council:

(a)To monitor the performance of the work.

(b)To determine the amount, kind, quality, sequence, and location of the work to be paid for hereunder and, when completed, to measure such work for payment.

(c)To determine all questions of an engineering character in relation to the work, to interpret the Plans, Specifications and Addenda.

(d)To determine how the work of this Contract shall be coordinated with the work of other contractors engaged simultaneously on this project.

(e)To make minor changes in the work as he deems necessary, provided such changes do not result in a net increase in the cost to the City or to the Contractor of the work to be done under the Contract.

(f)To amplify the Plans, add explanatory information and furnish additional Specifications and Drawings consistent with the intent of the Contract Documents.

The power of the Engineer shall not be limited to the foregoing enumeration, for it is the intent of this Contract that all of the work shall be subject to his determinations and approval, except where the determination or approval of someone other than the Engineer is expressly called for herein and except as subject to review by the Mayor and City Council. All orders of the Engineer requiring the Contractor to perform work as Contract work shall be promptly obeyed by the Contractor.

The Engineer shall not, however, have the power to issue an extra work order, and the performance of such work on the order of the Engineer without previously obtaining written confirmation thereof from the Mayor in accordance with Article 7.02 hereof may constitute a waiver of any right to extra compensation therefor. The Contractor is warned that the Engineer has no power to change the terms and provisions of this Contract, except minor changes where such change results in no net increase in the Contract Price.

ARTICLE 2.02 DIRECTOR

The Director of the Department in addition to those matters

expressly made subject to his determination, direction or approval in his capacity as "Engineer", shall also have the power:

(a)To review any and all questions in relation to this Contract and its performance, except as herein otherwise specifically provided, and his determination upon such review shall be final and conclusive upon the Contractor.

(b)With the approval of the Mayor and City Council to authorize modifications or changes in the Contract so as to require: (1) the performance of extra work, or (2) the omission of Contract work whenever he deems it in the interest of the City to do so, or both.

(c)To suspend the whole or any part of the work whenever, in his judgment, such suspension is required: (1) in the interest of the City generally, or (2) to coordinate the work of the various Contractors engaged on this project, or (3) to expedite the completion of the entire project, even though the completion of this particular Contract may be thereby delayed, without compensation to the Contractor for such suspension other than extending the time for the completion of the work, as much as it may have been, in the opinion of the City, delayed by such a suspension.

(d)If, before the final acceptance of all the work contemplated herein, it shall be deemed necessary to take over, use, occupy, or operate any part of the completed or partly completed work, the Engineer shall have the right to do so and the Contractor will not, in any way, interfere with or object to the use, occupation, or operation of such work by the City after receipt of notice in writing from the Engineer that such work or part thereof will be used by the City on and after the date specified in such notice. Such taking over, use, occupancy or operation of any part of the completed or partially completed work shall not constitute final acceptance or approval of any such part of the work.

ARTICLE 2.03 NO ESTOPPEL

The City shall not, nor shall any department, officer, agent, or employee thereof, be bound, precluded, or estopped by any determination, decision, acceptance, return, certificate, or payment made or given under or in connection with this Contract by any officer, agent or employee of the City at any time either before or after final completion and acceptance of the work and payment therefor: (a) from showing the true and correct classification, amount, quality, or character of the work done, or that any determination, decision, acceptance, return certificate or payment is untrue, incorrect or improperly made in any particular, or that the work or any part thereof does not in fact conform to the requirements of the Contract Documents, and (b) from demanding and recovering from the Contractor any overpayments made to him or such damages as it may sustain by reason his failure to comply with the requirements of the Contract of Documents, or both.

ARTICLE 2.04 NO WAIVER OF RIGHTS

Neither the inspection, nor any order, measurements or certificate of the City or its employees, officers, or agents, nor by any order of the City for payment of money, nor any money, nor payments for or acceptance of the whole or any part of the work by the City, nor any extension of time, nor any changes in the Contract, Specifications or Plans, nor any possession by the City or its employees shall operate as a

waiver of any provisions of this Contract, nor any power herein provided nor shall any waiver of any breach of this Contract be held as a waiver of any other subsequent breach.

Any remedy provided in this Contract shall be taken and construed as cumulative, namely, in addition to each and every other suit, action, or legal proceeding. The City shall be entitled as of right to an injunction against any breach of the provisions of this Contract.

SECTION 3 PERFORMANCE OF WORK

ARTICLE 3.01 CONTRACTOR'S RESPONSIBILITY

The Contractor shall do all the work and furnish, at his own cost and expense, all labor, materials, equipment, and other facilities, except as herein otherwise provided, as may be necessary and proper for performing and completing the work under this Contract. The Contractor shall be responsible for the entire work until completed and finally accepted by the City.

The work shall be performed in accordance with the true intent and meaning of the Contract Documents. Unless otherwise expressly provided, the work must be performed in accordance with the best modern practice, with materials as specified and workmanship of the highest quality, all as determined by and entirely to the satisfaction of the Engineer.

Unless otherwise expressly provided, the means and methods of construction shall be such as the Contractor may choose, subject, however, to the approval of the Engineer. Only adequate and safe procedure, methods, structures and equipment shall be used. The Engineer's approval or the Engineer's failure to exercise his right thereon shall not relieve the Contractor of obligations to accomplish the result intended by the Contract, nor shall such create a cause of action for damages.

ARTICLE 3.02 COMPLIANCE WITH LAWS

The Contractor must comply with all local, State and Federal laws, rules, ordinances and regulations applicable to this Contract and to the work done hereunder, and must obtain, at his own expense, all permits, licenses or other authorization necessary for the prosecution of the work.

No work shall be performed under this Contract on Sundays, legal holidays or after regular working hours without the express permission of the Engineer. Where such permission is granted, the Engineer may require that such work be performed without additional expense to the City.

ARTICLE 3.03 INSPECTION

During the progress of the work and up to the date of final acceptance, the Contractor shall, at all times, afford the representatives of the City, the Florida Department of Environmental Regulation, and if applicable, the Federal Environmental Protection Agency and the Federal Department of Labor every reasonable, safe and proper facility for inspecting the work done or being done at the

site. The inspection of any work shall not relieve the Contractor of any of his obligations to perform proper and satisfactory work as herein specified. Finished or unfinished work found not to be in strict accordance with the Contract shall be replaced as directed by the Engineer, even though such work may have been previously approved and payment made therefor.

The City shall have the right to reject materials and workmanship which are defective or require their correction. Rejected work and materials must be promptly removed from the site, which must at all times be kept in a reasonably clean and neat condition.

Failure or neglect on the part of the City to condemn or reject bad or inferior work or materials shall not be construed to imply an acceptance of such work or materials, if it becomes evident at any time prior to the final acceptance of the work by the City. Neither shall it be construed as barring the City at any subsequent time from the recovery of damages of such a sum of money as may be needed to build anew all portions of the work in which inferior work or improper materials were used, wherever found.

Should it be considered necessary or advisable by the City at any time before final acceptance of the entire work to make examinations of work already completed, by removing or tearing out all or portions of such work, the Contractor shall, on request, promptly furnish all necessary facilities, labor, and material for that purpose. If such work is found to be defective in any material respect, due to the fault of the Contractor or his subcontractors, he shall defray all expenses of such examination and of satisfactory reconstruction. If, however, such work is found to meet the requirements of the Contract, the cost of examination and restoration of the work shall be considered an item of extra work to be paid for in accordance with the provisions of Article 7.02 hereof.

ARTICLE 3.04 PROTECTION

During performance and until final acceptance, the Contractor shall be under an absolute obligation to protect the finished and unfinished work against any damage, loss, or injury. The Contractor shall take proper precaution to protect the finished work from loss or damage, pending completion and the final acceptance of all the work included in the entire Contract, provided that such precaution shall not relieve the Contractor from any and all liability and responsibility for loss or damage to the work occurring before final acceptance by the City. Such loss or damage shall be at the risk of and borne by the Contractor, whether arising from acts or omissions of the Contractor or others. In the event of any such loss or damage, the Contractor shall forthwith repair, replace, and make good the work without extension of time therefor, except as may be otherwise provided herein.

The provisions of this Article shall not be deemed to create any new right of action in favor of third parties against the Contractor or the City.

ARTICLE 3.05 PRESERVATION OF PROPERTY

The Contractor shall preserve from damage all property along the line of the work, or which is in the vicinity of or is in anywise affected by the work, the removal or destruction of which is not called for by the Plans. This applies, but is not limited, to the public utilities, trees, lawn areas, building monuments, fences, pipe and underground structures, public streets (except natural wear and tear of streets resulting from legitimate use thereof by the Contractor), and wherever such property is damaged due to the activities of the Contractor, it shall be immediately restored to its original condition by the Contractor and at his own expense.

In case of failure on the part of the Contractor to restore such property, or make good such damage or injury, the City may, upon forty-eight (48) hour written notice, proceed to repair, rebuild, or otherwise restore such property as may be deemed necessary, and the cost thereof will be deducted from any monies due or which may become due the Contractor under this Contract. Nothing in this clause shall prevent the Contractor from receiving proper compensation for the removal, damage, or replacement of any public or private property not shown on the Plans, when this is made necessary by alteration of grade or alignment authorized by the Engineer, provided that such property has not been damaged through fault of the Contractor, his employees or agents.

ARTICLE 3.06 BOUNDARIES

The Contractor shall confine his equipment, apparatus, the storage of materials, supplies and apparatus of his workmen to the limits indicated on the plans, by law, ordinances, permits or direction of the Engineer.

ARTICLE 3.07 SAFETY AND HEALTH REGULATIONS

The Contractor shall comply with the Department of Labor Safety and Health Regulations for construction promulgated under the Occupational Safety and Health Act of 1970 (PL 91- 596) and under Section 107 of the Contract Work Hours and Safety Standards Act (PL91-54).

ARTICLE 3.08 TAXES

All taxes of any kind and character payable on account of the work done and materials furnished under this Contract shall be paid by the Contractor and shall be deemed to have been included in his bid. The laws of the State of Florida provide that sales and use taxes are payable by the Contractor upon the tangible personal property incorporated in the work and such taxes shall be paid by the Contractor and shall be deemed to have been included in his bid.

ARTICLE 3.09 ENVIRONMENTAL CONSIDERATIONS

The Contractor, in the performance of the work under this Contract, shall comply with all Local, State and Federal laws, statutes, ordinances, rules and regulations applicable to protection of the environment; and, in the event he violates any of the provisions of same, he shall be answerable to the Local, State and Federal agencies designated by law to protect the environment. In the event the City receives, from any of the environmental agencies, a citation which is occasioned by an act or omission of the Contractor or his

subcontractor or any officers, employees or agents of either, it is understood and agreed that the Contractor shall automatically become a party-respondent under said citation; and the City immediately shall notify the Contractor and provide him with a copy of said citation.

The Contractor shall comply with the requirements of the citation and correct the offending condition(s) within the time stated in said citation and further shall be held fully responsible for all fines and/or penalties.

**SECTION 4
TIME PROVISIONS**

ARTICLE 4.01 TIME OF START AND COMPLETION

The Contractor must commence work within thirty (30) days subsequent to the date of the receipt of the "Notice to Proceed" by the City unless otherwise provided in the Specific Provisions and Special Instructions. Time being of the essence of this Contract, the Contractor shall thereafter prosecute the work diligently, using such means and methods of construction as well as secure its full completion in accordance with the requirements of the Contract Documents no later than the date specified therefor, or on the date to which the time for completion may be extended.

The Contractor must complete the work covered by this Contract in the number of consecutive calendar days set forth in the Instructions to Bidders, unless the date of completion is extended pursuant to the provisions of Article 4.05 hereof.

The period for performance shall start from the date of signing of this Agreement by the City.

The actual date of completion will be established after a final inspection as provided in Article 4.07 hereof.

ARTICLE 4.02 PROGRESS SCHEDULE

To enable the work to be laid out and prosecuted in an orderly and expeditious manner, the Contractor shall submit to the Engineer a proposed progress schedule within fifteen (15) days after the award of this Contract.

The schedule shall state the Contract starting date, time for completion and date of completion and shall show the anticipated time of starting and completion of each of the various operations to be performed under this Contract, together with all necessary and appropriate information regarding sequence and correlation of work and an estimated time required for the delivery of all materials and equipment required for the work. The proposed schedule shall be revised as directed by the Engineer until finally approved by him, and, after such approval, shall be strictly adhered to by the Contractor. The approved progress schedule may be changed only with the written permission of the Engineer.

If the Contractor shall fail to adhere to the approved progress schedule or the schedule as revised, he shall promptly adopt such other or additional means and methods of construction as will make up for the time lost, and will assure completion in accordance with the contract time.

ARTICLE 4.03 APPROVAL REQUESTS

From time to time, as the work progresses and in the sequence indicated by the approved schedule, the Contractor must submit to the Engineer a specific request, in writing, for each item of information or approval required of him by the Contract. These requests must be submitted sufficiently in advance of the date upon which the information or approval is actually required by the Contractor to allow for the time the Engineer may take to act upon such submissions or resubmissions. The Contractor shall not have any right to an extension of time on account of delays due to his failure to submit his requests for the required information or the required approval in accordance with these requirements.

ARTICLE 4.04 COORDINATION WITH OTHER CONTRACTORS

During progress of the work, other Contractors may be engaged in performing other work on this project or on other projects on the site. In that event, the Contractor shall coordinate the work to be done hereunder with the work of such other Contractors in such manner as the Engineer may direct.

ARTICLE 4.05 EXTENSION OF TIME

If such an application is made, the Contractor shall be entitled to an extension of time for delay in completion of the work should the Contractor be obstructed or delayed in the commencement, prosecution or completion of any part of said work by any act or delay of the City, or by acts or omissions of other Contractors on this project, or by a riot, insurrection, war, pestilence, acts of public authorities, fire, lightning, hurricanes, earthquakes, tornadoes, floods, extremely abnormal and excessive inclement weather as indicated by the records of the local weather bureau for a five-year period preceding the date of the Contract, or by strikes, or other causes, which causes of delay mentioned in this Article, in the opinion of the City, are entirely beyond the expectation and control of the Contractor.

The Contractor shall, however, be entitled to an extension of time for such causes only for the number of days of delay which the City may determine to be due solely to such causes and only to the extent that such occurrences actually delay the completion of the project and then only if the Contractor shall have strictly complied with all of the requirements of Articles 4.01, 4.02, 4.03 and 4.04 hereof. It is hereby understood that the determination by the Engineer as to the order and sequence of the work shall not in itself constitute a basis for extension of time.

The determination made by the City on an application for an extension of time shall be binding and conclusive on the Contractor.

Delays caused by failure of the Contractor's materialmen, manufacturers, and dealers to furnish approved working drawings, materials, fixtures, equipment, appliances, or other fittings on time or failure of subcontractors to perform their work shall not constitute a basis of extension of time.

The Contractor agrees to make no claim for damages for delay in the performance of this Contract occasioned by any

act or omission to act of the City or any of its representatives or because of any injunction which may be brought against the City or its representatives and agrees that any such claim shall be fully compensated for by an extension of time to complete performance of the work as provided herein.

ARTICLE 4.06 LIQUIDATED DAMAGES

It is mutually agreed between the parties that time is the essence of this Contract and that there will be on the part of the City considerable monetary damage in the event the Contractor should fail to complete the work within the time fixed for completion in the Contract or within the time to which such completion may have been extended.

The amount per day set forth in the Instructions to Bidders is hereby agreed upon as the liquidated damages for each and every calendar day that the time consumed in completing the work under this Contract exceeds the time allowed.

This amount shall, in no event, be considered as a penalty or otherwise than as the liquidated and adjusted damages to the City because of the delay and the Contractor and his Surety agree that the stated sum per day for each such day of delay shall be deducted and retained out of the monies which may become due hereunder and if not so deductible, the Contractor and his Surety shall be liable therefor.

ARTICLE 4.07 FINAL INSPECTION

When the work has been completed in accordance with the requirements of the Contract and final cleaning up performed, a date for final inspection of the work by the Engineer shall be set by the Contractor in a written request therefor, which date shall be not less than ten (10) days after the date of such request. The work will be deemed complete as of the date so set by the Contractor if, upon such inspection, the Engineer determines that no further work remains to be done at the site.

If such inspection reveals interms of work still to be performed, however, the Contractor shall promptly perform them and then request a reinspection. If, upon such inspection, the Engineer determines that the work is complete, the date of final completion shall be deemed to be the last day of such reinspection.

**SECTION 5
SUBCONTRACTS AND ASSIGNMENTS**

ARTICLE 5.01 LIMITATIONS AND CONSENT

The Contractor shall not assign, transfer, convey, sublet or otherwise dispose of this Contract or of his right, title, or interest therein, or his power to execute such Contract, or to assign any monies due or to become due thereunder to any other person, firm or corporation unless the previous written consent of the City shall first be obtained thereto and the giving of any such consent to a particular subcontract or assignment shall not dispense with the necessity of such consent to any further or other assignment.

Before making any subcontract, the Contractor must submit a

written statement to the Engineer, giving the name and address of the proposed contractor, the portion of the work and materials which he is to perform and furnish and any other information tending to prove that the proposed subcontractor has the necessary facilities, skill, integrity, past experience and financial resources to perform the work in accordance with the terms and conditions of this Contract.

If the City finds that the proposed subcontractor is qualified, the Contractor will be notified in writing. The City may revoke approval of any subcontractor when such subcontractor evidences an unwillingness or inability to perform his work in strict accordance with these Contract Documents. Notice of such revocation of approval will be given in writing to the Contractor.

The Contractor will promptly, upon request, file with the City a conformed copy of the subcontract. The Contractor shall cause appropriate provisions to be inserted in all subcontracts relative to the work to bind subcontractors to the Contractor by the terms of these Contract Documents, insofar as applicable to the work of subcontractors, and to give the Contractor the same power as regards terminating any subcontracts that the City may exercise over the Contractor under provisions of these Contract Documents.

The Contractor shall be required to perform with his own forces at least twenty-five (25) percent of the work, unless written consent to subcontract a greater percentage of the work is first obtained from the City.

ARTICLE 5.02 RESPONSIBILITY

The approval by the City of a subcontractor shall not relieve the Contractor of any of his responsibilities, duties, and liabilities hereunder. The Contractor shall be solely responsible to the City for the acts or defaults or omissions of his subcontractor and of such subcontractor's officers, agents, and employees, each of whom shall for all purposes be deemed to be the agent or employee of the Contractor. Nothing contained in the Contract Documents shall create any contractual relationship between any subcontractor and the City.

**SECTION 6
SECURITY AND GUARANTY**

ARTICLE 6.01 CONTRACT SECURITY

The Contractor shall execute and deliver to the City a Performance Bond on the form as provided herein, in an amount at least equal to one hundred (100) percent of the full Contract price, such Bond to be executed by a surety company acceptable to the City. The surety on such Performance Bond shall be a surety company duly authorized to do business in the State of Florida, and the Bond shall be issued or countersigned by a local resident producing agent of such surety company who is a resident of the State of Florida, regularly commissioned and licensed in said State, and satisfactory evidence of the authority of the person or persons executing such Bond shall be submitted with the Bond. The Performance Bond shall serve as security for the faithful performance of this Contract, including

maintenance and guaranty provisions, and for the payment of all persons performing labor and furnishing materials in connection with the Contract. The premiums on the Performance Bond shall be paid by the Contractor.

If, at any time, the City shall become dissatisfied with any surety or sureties then upon the Performance Bond, or if for any other reason such bond shall cease to be adequate security for the City, the Contractor shall, within five days after notice so to do, substitute an acceptable Bond in such form and sum and signed by such other sureties as may be satisfactory to the City. The premiums on such Bond shall be paid by the Contractor. No further partial payments shall be deemed due or shall be made until the new sureties have qualified.

ARTICLE 6.02 CONTRACTORS INSURANCE

Insurance required shall be as indicated on Special Instructions pages beginning with "INS-1"

ARTICLE 6.03 AGAINST CLAIMS AND LIENS

The City may withhold from the Contractor as much as any approved payments to him as may, in the opinion of the City, be necessary to secure (a) just claims of any persons supplying labor or materials to the Contractor or any of his subcontractors for the work then due and unpaid; (b) loss due to defective work not remedied, or (c) liability, damage, or loss due to injury to persons or damages to the work or property of other contractors, subcontractors, or others, caused by the act or neglect of the Contractor or of any of his subcontractors. The City shall have the right, as agent for the Contractor, to apply any such amounts so withheld in such manner as the City may deem proper to satisfy such claims or to secure such protection. Such application of such money shall be deemed payments for the account of the Contractor.

ARTICLE 6.04 MAINTENANCE AND GUARANTY

The Contractor hereby guarantees all the work furnished under this Contract against any defects in workmanship and materials for a period of one year following the date of final acceptance of the work by the City. Under this guarantee, the Contractor hereby agrees to make good, without delay, at his own expense, any failure of any part of the work due to faulty materials or manufacture, construction, or installation, or the failure of any equipment to perform satisfactorily all the work put upon it within the limits of the Contract Documents, and further, shall make good any damage to any part of the work caused by such failure. It is hereby agreed that the Performance Bond shall fully cover all guarantees contained in this Article.

It is also agreed that all warranties, expressed or implied, inure to the benefit of the City and are enforceable by the City.

**SECTION 7
CHANGES**

ARTICLE 7.01 MINOR CHANGES

The City reserves the right to make such additions, deductions, or changes to this Contract from time to time as

it deems necessary and in a manner not materially affecting the substance thereof or materially changing the price to be paid in order to carry out and complete more fully and perfectly the work herein agreed to be done and performed. This Contract shall in no way be invalidated by any such additions, deductions, or changes, and no claim by the Contractor shall be made for any loss of anticipated profits thereby.

Construction conditions may require that minor changes be made in the location and installation of the work and equipment to be furnished and other work to be performed hereunder, and the Contractor when ordered by the Engineer, shall make such adjustments and changes in said locations and work as may be necessary, without additional cost to the City, provided such adjustments and changes do not alter the character, quantity or cost of the work as a whole, and provided further that Plans and Specifications showing such adjustments and changes are furnished to the Contractor by the City within a reasonable time before any work involving such adjustment and changes is begun. The Engineer shall be the sole judge of what constitutes a minor change for which no additional compensation shall be allowed.

ARTICLE 7.02 EXTRA WORK

The City may at any time by a written order and without notice to the sureties require the performance of such extra work as it may find necessary or desirable. An order for extra work shall be valid only if issued in writing and signed by the Mayor and the work so ordered must be performed by the Contractor.

The amount of compensation to be paid to the Contractor for any extra work as so ordered shall be determined as follows:

(a) By such applicable unit prices, if any, as are set forth in the Proposal; or

(b) If no such unit prices are set forth then by a lump sum or other unit prices mutually agreed upon by the City and the Contractor; or

(c) If no such unit prices are set forth in the Proposal and if the parties cannot agree upon a lump sum or other unit prices then by the actual net cost in money to the Contractor of the extra work performed, which cost shall be determined as follows:

(1) For all labor and foreman in direct charge of the authorized operations, the Contractor shall receive the current local rate of wages to be agreed upon, in writing, before starting such work for each hour that said labor and foremen are actually engaged thereon, to which shall be added an amount equal to 25 percent of the sum thereof which shall be considered and accepted as full compensation for general supervision, FICA taxes, contributions under the Florida Unemployment Compensation Act, insurance, bond, subcontractor's profit and overhead, the furnishing of small tools and miscellaneous equipment used, such as picks, shovels, hand pumps, and similar items.

(2) For all materials used, the Contractor shall receive the actual cost of such materials delivered at the site or previously approved delivery point as established by original receipted bills. No percentage shall be added to this cost.

(3) For special equipment and machinery such as power-driven pumps, concrete mixers, trucks, and tractors, or other equipment, required for the economical performance of the authorized work, the Contractor shall receive payment based on the average local area rental price for each item of equipment and the actual time of its use on the work. No percentage shall be added to this sum.

(4) Records of extra work done under this procedure shall be reviewed at the end of each day by the Contractor or his representative and the Engineer. Duplicate copies of accepted records shall be made and signed by both Contractor or his representative and the Engineer, and one copy retained by each.

Request for payment for approved and duly authorized extra work shall be submitted in the same form as Contract work or in the case of work performed under paragraph (c) (1) above upon a certified statement supported by receipted bills. Such statement shall be submitted for the current Contract payment for the month in which the work was done.

ARTICLE 7.03 DISPUTED WORK

If the Contractor is of the opinion that any work required, necessitated, or ordered violates the terms and provisions of this Contract, he must promptly notify the Engineer, in writing, of his contentions with respect thereto and request a final determination thereof. If the Engineer determines that the work in question is Contract work and not extra work or that the order complained of is proper, he will direct the Contractor to proceed and the Contractor shall promptly comply. In order, however, to reserve his right to claim compensation for such work or damages resulting from such compliance, the Contractor must, within five (5) days after receiving notice of the Engineer's determination and direction, notify the City in writing that the work is being performed or that the determination and direction is being complied with under protest. Failure of the Contractor to notify shall be deemed as a waiver of claim for extra compensation or damages therefor.

Before final acceptance by the City, all matters of dispute must be adjusted to the mutual satisfaction of the parties thereto. Final determinations and decisions, in case any questions shall arise, shall constitute a condition precedent to the right of the Contractor to receive the money therefor until the matter in question has been adjusted.

ARTICLE 7.04 OMITTED WORK

The City may at any time by a written order and without notice to the sureties require the omission of such Contract work as it may find necessary or desirable.

An order for omission of work shall be valid only if signed by the Mayor and the work so ordered must be omitted by the Contractor. The amount by which the Contract price shall be reduced shall be determined as follows:

(a) By such applicable unit prices, if any, as are set forth in the Contract; or

(b) By the appropriate lump sum price set forth in the Contract; or

(c) By the fair and reasonable estimated cost to the City

of such omitted work as determined by the Engineer and approved by the City.

SECTION 8 CONTRACTOR'S EMPLOYEES

ARTICLE 8.01 CHARACTER AND COMPETENCY

The Contractor and his subcontractors shall employ upon all parts of the work herein contracted for only competent, skillful, and trustworthy workers. Should the Engineer at any time give notice, in writing, to the Contractor or his duly authorized representative on the work that any employee in his opinion is incompetent, unfaithful, disorderly, careless, unobservant of instructions, or in any way a detriment to the satisfactory progress of the work, such employee shall immediately be dismissed and not again allowed upon the site.

ARTICLE 8.02 SUPERINTENDENCE

The Contractor shall give his personal supervision to the faithful prosecution of the work and in case of his absence shall have a competent, experienced, and reliable supervisor or superintendent, acceptable to the Engineer on the site who shall follow without delay all instructions of the Engineer in the prosecution and completion of the work and every part thereof, in full authority to supply workers, material, and equipment immediately. He shall keep on hand at all times copies of the Contract Documents.

ARTICLE 8.03 EMPLOYMENT OPPORTUNITIES

The Contractor shall, in the performance of the work required to be done under this Contract, employ all workers without discrimination regarding race, creed, color, sex or national origin and must not maintain or provide facilities that are segregated on the basis of race, color, creed or national origin.

ARTICLE 8.04 RATES OF WAGES

On federally assisted projects, the rates of wages to be paid under this Contract shall not be less than the rates of wages set forth in Section 12 of this Agreement.

On other projects, no wage rate determination is included. Florida's Prevailing Wage Law (Section 215.19, Florida Statutes) was repealed effective April 25, 1979.

ARTICLE 8.05 PAYROLL REPORTS

The Contractor and each subcontractor shall, if requested to do so, furnish to the Engineer a duly certified copy of his payroll and also any other information required by the Engineer to satisfy him that the provisions of the law as to the hours of employment and rate of wages are being observed.

Payrolls shall be prepared in accordance with instructions furnished by the City and on approved forms. The Contractor shall not carry on his payroll any persons not employed by him. Subcontractor's employees shall be carried only on the payrolls of the employing subcontractor.

SECTION 9 CONTRACTOR'S DEFAULT

ARTICLE 9.01 CITY'S RIGHT AND NOTICE

It is mutually agreed that: (a) if the Contractor fails to begin work when required to do so, or (b) if at any time during the progress of the work it shall appear to the Engineer that the Contractor is not prosecuting the work with reasonable speed, or is delaying the work unreasonably and unnecessarily, or (c) if the force of workmen or quality or quantity of material furnished are not sufficient to insure completion of the work within the specified time and in accordance with the Specifications hereto attached, or (d) if the Contractor shall fail to make prompt payments for materials or labor or to subcontractors for work performed under the Contract, or (e) if legal proceedings have been instituted by others than the City in such manner as to interfere with the progress of the work and may subject the City to peril of litigation or outside claims of (f) if the Contractor shall be adjudged a bankrupt or make an assignment for the benefit of creditors, or (g) if in any proceeding instituted by or against the Contractor an order shall be made or entered granting an extension of time of payment, composition, adjustment, modification, settlement or satisfaction of his debts or liabilities, or (h) if a receiver or trustee shall be appointed for the Contractor or the Contractor's property, or (i) if the Contract or any part thereof shall be sublet without the consent of the City being first obtained in writing, or (j) if this Contract or any right, monies, or claim thereunder shall be assigned by the Contractor, otherwise than as herein specified, or (k) if the Contractor shall fail in any manner of substance to observe the provisions of this Contract, or (l) if any of the work, machinery, or equipment shall be defective, and shall not be replaced as herein provided, or (m) if the work to be done under this Contract shall be abandoned, then such fact or conditions shall be certified by the Engineer and thereupon the City without prejudice to any other rights or remedies of the City, shall have the right to declare the Contractor in default and so notify the Contractor by a written notice, setting forth the ground or grounds upon which such default is declared and the Contractor must discontinue the work, either as a portion of the work or the whole thereof, as directed.

ARTICLE 9.02 CONTRACTOR'S DUTY UPON DEFAULT

Upon receipt of notice that his Contract is in default, the Contractor shall immediately discontinue all further operations on the work or such part thereof, and shall immediately quit the site or such part thereof, leaving untouched all plant, materials, equipment, tools, and supplies.

ARTICLE 9.03 COMPLETION OF DEFAULTED WORK

The City, after declaring the Contractor in default, may then have the work completed or the defective equipment or machinery replaced or anything else done to complete the work in strict accordance with the Contract Documents by such means and in such manner, by Contract with or without public letting, or otherwise, as it may deem advisable,

utilizing for such purpose without additional cost to the City such of the Contractor's plant, materials, equipment, tools, and supplies remaining on the site, and also such subcontractors as it may deem advisable.

The City shall reimburse all parties, including itself, for the expense of such completion, including liquidated damages, if any, and the cost of reletting. The City shall deduct this expense from monies due or to become due to the Contractor under this Contract, or any part thereof, and in case such expense is more than the sum remaining unpaid of the original contract price, the Contractor and his sureties shall pay the amount of such deficiency to the City.

ARTICLE 9.04 PARTIAL DEFAULT

In case the City shall declare the Contractor in default as to a part of the work only, the Contractor shall discontinue such part, shall continue performing the remainder of the work in strict conformity with the terms of the Contract, and shall in no way hinder or interfere with any other contractor or person whom the City may engage to complete the work as to which the Contractor was declared in default.

SECTION 10 PAYMENTS

ARTICLE 10.01 PRICES

For the Contractor's complete performance of the work, the City will pay and the Contractor agrees to accept, subject to the terms and conditions hereof, the lump sum prices or unit prices in the Contractor's Proposal and the award made therein, plus the amount required to be paid for any extra work ordered under Article 7.02 hereof, less credit for any work omitted pursuant to Article 7.04 hereof. Under unit price items, the number of units actually required to complete the work under the Contract may be more than stated in the Proposal. The Contractor agrees that no claim will be made for any damages or for loss of profits because of a difference between the quantities of the various classes of work assumed and stated in the Proposal Form as a basis for comparing Proposals and the quantities of work actually performed.

The sum as awarded for any lump sum Contract or lump sum Contract Item shall represent payment in full for all of the various classes of work, including materials, equipment, and labor necessary or required to complete, in conformity with the Contract Document, the entire work shown, indicated or specified under the lump sum Contract or lump sum Contract Item.

The amount as awarded as a unit price for any unit price Contract Item shall represent payment in full for all the materials, equipment, and labor necessary to complete, in conformity with the Contract Documents, each unit of work shown, specified, or required under the said unit price Contract Item.

No payment other than the amount as awarded will be made for any class of work included in a lump sum Contract Item or a unit price Contract Item, unless specific provision is

made therefor in the Contract Documents.

ARTICLE 10.02 SUBMISSION OF BID BREAKDOWN

Within fifteen (15) days after the execution of this Contract, the Contractor must submit to the Engineer in duplicate an acceptable breakdown of the lump sums and unit prices bid for items of the Contract, showing the various operations to be performed under the Contract, as described in the progress schedule required under Article 4.02 hereof, and the value of each of such operations, the total of such items to equal the total price bid. The Contractor shall also submit such other information relating to the bid prices as may be required and shall revise the bid breakdown as directed. Thereafter, the breakdown may be used for checking the Contractor's applications for partial payments hereunder but shall not be binding upon the City or the Engineer for any purpose whatsoever.

ARTICLE 10.03 REPORTS, RECORDS AND DATA

The Contractor shall furnish to the Engineer such schedules of quantities and costs, progress schedules, reports, invoices, delivery tickets, estimates, records, and other data as the Engineer may request concerning work performed or to be performed and the materials furnished under the Contract.

ARTICLE 10.04 PAYMENTS BY CONTRACTOR

The Contractor shall pay (a) for all transportation and utility services not later than the 20th day of the calendar month following that in which such services are rendered, (b) for all materials, tools, and equipment delivered at the site of the project, and the balance of the cost thereof not later than the 30th day following the completion of that part of the work in or on which such materials, tools, and equipment are incorporated or used, and (c) to each of his subcontractors, not later than the 5th day following each payment to the Contractor, the respective amounts allowed the Contractor on account of the work performed by his subcontractors, to the extent of each subcontractor's interest therein; and proof of such payments or releases therefor shall be submitted to the Engineer upon request.

ARTICLE 10.05 PARTIAL PAYMENTS

On or about the first of each month, the Contractor shall make and certify an estimate, on forms prescribed by the City, of the amount and fair value of the work done, and may apply for partial payment therefor. The Contractor shall revise the estimate as the Engineer may direct. When satisfactory progress has been made, and shows that the value of the work completed since the last payment exceeds one percent (1%) of the total Contract price in amount, the Engineer will issue a certificate that such work has been completed and the value thereof. The City will then issue a voucher to the Contractor in accordance with the following schedule:

FOR CONTRACT AMOUNTS UNDER \$250,000

(A) In the amount of ninety percent (90%) of the value of the work completed as certified until construction is one hundred percent (100%) complete (operational or beneficial occupancy), the withheld amount may be reduced below ten percent (10%), at the Engineer's option, to only that amount necessary to assure completion.

FOR CONTRACT AMOUNTS OVER \$250,000

(A) In the amount of ninety percent (90%) of the value of the work completed as certified until construction is fifty percent (50%) complete.

(B) When the dollar value, as determined by the Engineer, of satisfactorily completed work in place is greater than fifty percent (50%) of the original contract price, vouchers for partial payment will be issued by the City to the Contractor in the amount of one hundred percent (100%) of the value of the work, above 50%, completed as certified for that payment period.

(C) If the Contractor has performed satisfactorily and the work is substantially complete (operational or beneficial occupancy) the withheld amount may be reduced, at the Engineer's option, to only that amount necessary to assure completion.

In addition to the Conditions set forth in (A), (B), and (C) above, payments will always be less any sums that may be retained or deducted by the City under the terms of any of the contract documents and less any sums that may be retained to cover monetary guarantees for equipment, materials or progress performance.

Payment on estimates made on or about the first of the month may be expected on or about the 20th of the month.

Unless specified otherwise in the Contract Items, the delivered cost of equipment and nonperishable materials suitably stored at the site of the work and tested for adequacy may be included in the Contractor's application for partial payment provided, however, that the Contractor shall furnish evidence satisfactory to the City that the Contractor is the unconditional owner and in possession of such materials or equipment. The amount to be paid will be 90 percent of the invoice cost to the Contractor which cost shall be supported by receipted bills within 30 days of the date of payment by the City to the Contractor. Such payment shall not relieve the Contractor from full responsibility for completion of the work and for protection of such materials and equipment until incorporated in the work in a permanent manner as required by the Contract Documents.

Before any payment will be made under this Contract, the Contractor and every subcontractor, if required, shall deliver to the Engineer a written, verified statement, in satisfactory form, showing in detail all amounts then due and unpaid by such Contractor or subcontractor to all laborers, workmen, and mechanics, employed by him under the Contract for the performance of the work at the site thereof, for daily or weekly wages, or to other persons for materials, equipment, or supplies delivered at the site of the work during the period covered by the payment under consideration.

ARTICLE 10.06 FINAL PAYMENT

Under determination of satisfactory completion of the work under this Contract as provided in Article 4.07 hereof, the Engineer will prepare the final estimate showing the value of the completed work. This estimate will be prepared within 30 days after the date of completion or as soon thereafter as the necessary measurements and computations can be made.

All prior certificates and estimates, being approximate only, are subject to correction in the final estimate and payment.

When the final estimate has been prepared and certified by Engineer, he will submit to the Mayor and City Council the final certificate stating that the work has been completed and the amount based on the final estimate remaining due to the Contractor. The City will then accept the work as fully completed and will, not later than 30 days after the final acceptance, as defined in Article 1.02, of the work done under this Contract, pay the Contractor the entire amount so found due thereunder after deduction of all previous payments and all percentages and amounts to be kept and retained under provisions of this Contract; provided, however, and it is understood and agreed that, as a precedent to receiving final payment, the Contractor shall submit to the City a sworn affidavit that all bills for labor, service, materials, and subcontractors have been paid and that there are no suits pending in connection with this work. The City, at its option, may permit the Contractor to execute a separate surety bond in a form satisfactory to the City. The surety bond shall be in the full amount of the suit or suits.

Neither the final payment nor any part of the retained percentage shall be paid until the Contractor, if required, shall furnish the City with a complete release from any should remain unsatisfied after all payments are made, the Contractor shall refund to the City all monies which the City may be compelled to pay in discharging such claim, including incidental costs and attorney's fees.

ARTICLE 10.07 ACCEPTANCE OF FINAL PAYMENT

The acceptance by the Contractor, or by anyone claiming by or through him, of the final payment shall operate as and shall be a release to the City and every officer and agent thereof from any and all claims and liability to the Contractor for anything done or furnished in connection with the work or project and for any act or neglect of the Contractor or of any others relating to or affecting the work. No payment, however, final or otherwise, shall operate to release the Contractor or his sureties from any obligations under this Contract or the Performance Bond.

SECTION 11 MISCELLANEOUS PROVISIONS

ARTICLE 11.01 CONTRACTOR'S WARRANTIES

In consideration of, and to induce the award of this contract to him, the Contractor represents and warrants:

- (a) That he is not in arrears to the City upon debt or contract, and he is not a defaulter, as surety, contractor, or otherwise.
- (b) That he is financially solvent and sufficiently experienced and competent to perform the work.
- (c) That the work can be performed as called for by the Contract Documents.
- (d) That the facts stated in his proposal and the information given by him are true and correct in all respects.
- (e) That he is fully informed regarding all the conditions affecting the work to be done and labor and materials to be

furnished for the completion of this Contract, and that his information was secured by personal investigation and research.

ARTICLE 11.02 PATENTED DEVICES, MATERIAL AND PROCESSES

It is mutually understood and agreed that Contract prices include all royalties and costs arising from patents, trademarks, and copyrights in any way involved in the work. Whenever the Contractor is required or desires to use any design, device, material, or process covered by letters of patent or copyright, the Contractor shall indemnify and save harmless the City, its officers, agents and employees from any and all claims for infringement by reason of the use of any such patented design, device, tool, material, equipment, or process, to be performed under the Contract, and shall indemnify the said City, its officers, agents, and employees for any costs, expenses, and damages which may be incurred by reason of such infringement at any time during the prosecution or after completion of the work.

ARTICLE 11.03 SUITS AT LAW

In case any action at law or suit in equity may or shall be brought against the City or any of its officers, agents, or employees for or on account of the failure, omission, or neglect of the Contractor or his subcontractors, employees, or agents, to do or perform any of the covenants, acts, matters, or things by this Contract undertaken to be done or performed by the Contractor or his subcontractors, employees, or agents, or from any injuries done to property or persons and caused by the negligence or alleged negligence of the Contractor or his subcontractors, employees, or agents, or in any other manner arising out of the performance of this Contract, then the Contractor shall immediately assume and take charge of the defense of such actions or suits in like manner and to all intents and purposes as if said actions or suits have been brought directly against the Contractor, and the Contractor shall also indemnify and save harmless the City, its officers, agents, and employees from any and all loss, cost or damage whatever arising out of such actions or suits, in like manner and to all intents and purposes as if said actions or suits have been brought directly against the Contractor.

The Contractor shall and does hereby assume all liability for and agrees to indemnify the City or its Engineer against any or all loss, costs, damages, and liability for any or by reason of any lien, claims or demands, either for materials purchased or for work performed by laborers, mechanics, and others and from any damages, costs, actions, or causes of action and judgement arising from injuries sustained by mechanics, laborers, or other persons by reason of accidents or otherwise, whether caused by the carelessness or inefficiency or neglect of said Contractor, his subcontractors, agents, employees, workmen or otherwise.

ARTICLE 11.04 CLAIMS FOR DAMAGES

If the Contractor shall claim compensation for any damage sustained, other than for extra or disputed work covered by Article 7.02 and 7.03 hereof, by reason of any act or omission of the City, its agents, or any persons, he shall, within five days after sustaining such damage, make and

deliver to the Engineer a written statement of the nature of the damage sustained and of the basis of the claim against the City. On or before the 15th of the month succeeding that in which any damage shall have been sustained, the Contractor shall make and deliver to the Engineer an itemized statement of the details and amounts of such damage, duly verified by the Contractor. Unless such statements shall be made delivered within the times aforesaid, it is stipulated that and all claims for such compensation shall be forfeited and invalidated, and the Contractor shall not be entitled to payment on account of such claims.

ARTICLE 11.05 NO CLAIMS AGAINST INDIVIDUALS

No claim whatsoever shall be made by the Contractor against any officer, agent, employee of the City for, or on account of, anything done or omitted to be done in connection with this Contract.

ARTICLE 11.06 LIABILITY UNAFFECTED

Nothing herein contained shall in any manner create any liability against the City on behalf of any claim for labor, services, or materials, or of subcontractors, and nothing herein contained shall affect the liability of the Contractor or his sureties to the City or to any workmen or materialsmen upon bond given in connection with this Contract.

ARTICLE 11.07 INDEMNIFICATION PROVISIONS

Whenever there appears in this Agreement, or in the other Contract Documents made a part hereof, an indemnification provision within the purview of Chapter 725.06, Laws of Florida, the monetary limitation on the extent of the indemnification under each such provision shall be One Million Dollars or a sum equal to the total Contract price, whichever shall be the greater.

ARTICLE 11.08 UNLAWFUL PROVISIONS DEEMED STRICKEN

If this contract contains any unlawful provisions not an essential part of the Contract and which shall not appear to have a controlling or material inducement to the making thereof, such provisions shall be deemed of no effect and shall, upon notice by either party, be deemed stricken from the Contract without affecting the binding force of the remainder.

ARTICLE 11.09 LEGAL PROVISIONS DEEMED INCLUDED

Each and every provision of any law and clause required by law to be inserted in this Contract shall be deemed to be inserted herein, and the Contract shall be read and enforced as though it were included herein and if, through mistake or otherwise, any such provision is not inserted or is not correctly inserted, then upon application of either party the Contract shall forthwith be physically amended to make such insertion.

ARTICLE 11.10 DEATH OR INCOMPETENCY OF CONTRACTOR

In the event of death or legal incompetency of a Contractor who shall be an individual or surviving member of a contracting firm, such death or adjudication of incompetency

shall not terminate the Contract, but shall act as default hereunder to the effect provided in Article 9.01 hereof and the estate of the Contractor and his surety shall remain liable hereunder to the same extent as though the Contractor had lived. Notice of default, as provided in Article 9.01 hereof, shall not be required to be given in the event of such death or adjudication of incompetency.

ARTICLE 11.11 NUMBER AND GENDER OF WORDS

Whenever the context so admits or requires, all references herein in one number shall be deemed extended to and including the other number, whether singular or plural, and the use of any gender shall be applicable to all genders.

ARTICLE 11.12 ACCESS TO RECORDS

Representatives of Federal Agencies, if applicable, and the State of Florida shall have access to the work whenever it is in preparation of progress. On federally assisted projects the Federal Agency, the Comptroller General of the United States, or any authorized representative shall have access to any books, documents, papers, and records of the Contractor which are pertinent to the project for the purpose of making audit, examination, excerpts, and transcription thereof.

**SECTION 12
LABOR STANDARDS**

ARTICLE 12.01 LABOR STANDARDS

The Contractor shall comply with all of the regulations set forth in "Labor Standards Provisions for Federally Assisted Construction Contracts", which may be attached, and any applicable Florida Statutes.

ARTICLE 12.02 NOTICE TO LABOR UNIONS

If required, the Contractor shall provide Labor Unions and other organizations of workers, and shall post, in a conspicuous place available to employees or applicants for employment, a completed copy of the form entitled "Notice to Labor Unions or Other Organizations of Workers" attached to and made a part of this Agreement.

ARTICLE 12.03 SAFETY AND HEALTH REGULATIONS

The Contractor shall comply with the Department of Labor Safety and Health Regulations for construction promulgated under the Occupational Safety and Health Act of 1970 (PL 91- 596) and under Section 107 of the Contract Work Hours and Safety Standards Act (PL 91-54). Nothing in these Acts shall be construed to supersede or in any manner affect any worker's compensation law or statutory rights, duties, or liabilities of employers and employees under any law with respect to injuries, diseases, or death of employees arising out of, or in the course of, employment.

ARTICLE 12.04 EEO AFFIRMATIVE ACTION REQUIREMENTS

The Contractor understands and agrees to be bound by the equal opportunity requirements of Federal regulations which shall be applicable throughout the performance of work under this Contract. The Contractor also agrees to similarly

bind contractually each subcontractor. In policies, the Contractor agrees to engage in Affirmative Action directed at promoting and ensuring equal employment opportunity in the work force used under the Contract (and the Contractor agrees to require contractually the same effort of all subcontractors whose subcontractors exceed \$100,000). The Contractor understands and agrees that "Affirmative Action" as used herein shall constitute a good faith effort to achieve and maintain minority employment in each trade in the on-site work force used on the Contract.

ARTICLE 12.05 PREVAILING RATES OF WAGES

Florida's prevailing wage law was repealed effective April 25, 1979.

For Federally assisted projects, appropriate prevailing wage rate determinations are indicated on pages beginning with WR-1.

* * * * *

IN WITNESS THEREOF, the parties have hereunto set their hands and seals, and such of them as are corporation have caused these present to be signed by their duly authorized officers.

CITY OF TAMPA, FLORIDA

Bob Buckhorn, Mayor
(SEAL)

ATTEST:

City Clerk

Approved as to Form:
The execution of this document was authorized
by Resolution No. _____

Rachel S. Peterkin, Assistant City Attorney

Contractor

By: _____
(SEAL)

Title:

ATTEST:

Witness

TAMPA AGREEMENT (ACKNOWLEDGMENT OF PRINCIPAL)

STATE OF _____)
) SS:
COUNTY OF _____)

For a Corporation:

STATE OF _____
COUNTY OF _____

The foregoing instrument was acknowledged before me this ___ of _____, 20___ by _____ of _____, a _____ corporation, on behalf of the corporation. He/she is ___ personally known or has ___ produced _____ as identification.

Notary

My Commission Expires:

For an Individual:

STATE OF _____
COUNTY OF _____

The foregoing instrument was acknowledged before me this ___ of _____, 20___ by _____ who is ___ personally known to me or has ___ produced _____ as identification.

Notary

My Commission Expires:

For a Firm:

STATE OF _____
COUNTY OF _____

The foregoing instrument was acknowledged before me this ___ of _____, 20___ by _____ who signed on behalf of the said firm. He/she is ___ personally known or has ___ produced _____ as identification.

Notary

My Commission Expires:

PUBLIC CONSTRUCTION BOND

Bond No. (enter bond number) _____

Name of Contractor: _____

Principal Business Address of Contractor: _____

Telephone Number of Contractor: _____

Name of Surety (if more than one list each): _____

Principal Business Address of Surety: _____

Telephone Number of Surety: _____

Owner is The City of Tampa, Florida

Principal Business Address of Owner: _____ 306 E Jackson St, Tampa, FL 33602

_____ Contract Administration Department (280A4N)

Telephone Number of Owner: _____ 813/274-8456

Contract Number Assigned by City to contract which is the subject of this bond: _____

Legal Description or Address of Property Improved or Contract Number is: _____

General Description of Work and Services: _____

KNOW ALL MEN BY THESE PRESENTS That we, _____

(Name of Contractor)

as Principal, hereinafter called CONTRACTOR, of the State of _____, and

(Name of Surety)

a corporation organized and existing under and by virtue of the laws of the State of _____, and regularly authorized to do business in the State of Florida, as SURETY, are held and firmly bound unto the City of Tampa, a municipal corporation organized and existing under the laws of the State of Florida, hereinafter called Owner, in the penal sum of _____ Dollars and _____ Cents (\$ _____), lawful money of the United States of America, for the payment whereof well and truly to be made, we bind ourselves, our heirs, executors, and administrators, successors and assigns, jointly and severally, firmly by these presents.

THE CONDITION OF THIS BOND is that if Principal:

1. Performs the contract dated _____, _____, 20____, between Principal and Owner for construction of _____, the contract being made a part of this bond by reference, in the time and in the manner prescribed in the contract; and
2. Promptly makes payments to all claimants, as defined in Section 255.05(1) (Section 713.01), Florida Statutes, supplying Principal with labor, materials, or supplies, used directly or indirectly by Principal in the prosecution of the work provided for in the contract; and
3. Pays Owner all losses, damages, expenses, costs, and attorney's fees, including appellate proceedings, that Owner sustains because of a default by Principal under the contract; and
4. Performs the guarantee of all work and materials furnished under the contract for the time specified in the contract, then this bond is void; otherwise it remains in full force.
5. Contractor and Surety acknowledge that the Work for which this bond has been issued may be one of several such contract documents for a group of projects. This bond does not secure covenants to pay for or to perform design services survey or program management services. The Owner/Obligee is expected to reasonably account for damages that are caused to Owner with respect to Principal's (Contractor's) default in performance of the scope of the Work incorporated by reference into the bond, and notwithstanding any contractual or common law remedy permitted to Owner as against Contractor, the obligation of Surety for any damages under this bond shall be determined by the cost of completion of the Work less the contract balance unpaid upon default of Contractor for the Work plus liquidated damages at the rate of \$500.00 per day for delays by the Contractor and/or Surety in reaching substantial completion.
6. The notice requirements for claimants and conditions for entitlement to payment set forth in Section 255.05, Fla. Stat. and the limitations period to actions upon Section 255.05, Fla. Stat. bonds apply to claimants seeking payment from surety under this bond. Any action instituted by a claimant under this bond for payment must be in accordance with the notice and time limitation provisions in Section 255.05, Florida Statutes.
7. The Surety, for value received, hereby stipulates and agrees that no changes, extensions of time, alterations or additions to the terms of the contract documents or other Work to be performed hereunder, or the specifications referred to therein shall in any way affect its obligations under this bond, and it does hereby waive notice of any such changes, extensions of time, alterations or additions to the terms of the Contract or to Work or to the specifications.

8. The above SURETY states that it has read all of the Contract Documents made by the CONTRACTOR with the CITY, hereto attached, and the terms and conditions of the contract and work, and is familiar therewith and in particular those portions of the Agreement concerning the guaranty of such CONTRACTOR for a period of one year following the date of the final acceptance of the completed work under the Contract by the CITY, all of which this BOND includes.

DATED ON _____, 20__

(Name of Principal)

(Name of Surety)

(Principal Business Address)

(Surety Address)

By _____

By _____
(As Attorney in Fact)*

Title _____

Telephone Number of Surety

Telephone Number of Principal

Approved as to legal sufficiency:

Countersignature:

By _____
Assistant City Attorney

(Name of Local Agency)

(Address of Resident Agent)

By _____

Title _____

Telephone Number of Local Agency

*(As Attorney in Fact) attach Power of Attorney and Current Certificate with Original Signature

SPECIFICATIONS GENERAL PROVISIONS

SECTION 1 SCOPE AND INTENT

G-1.01 DESCRIPTION

The work to be done consists of the furnishing of all labor, materials and equipment, and the performance of all work included in this Contract.

G-1.02 WORK INCLUDED

The Contractor shall furnish all labor, superintendence, materials, plant, power, light, heat, fuel, water, tools, appliances, equipment, supplies, and other means of construction necessary or proper for performing and completing the work. He shall obtain and pay for all required permits. He shall perform and complete the work in the manner best calculated to promote rapid construction consistent with safety of life and property and to the satisfaction of the Engineer, and in strict accordance with the Contract Documents. The Contractor shall clean up the work and maintain it during and after construction, until accepted, and shall do all work and pay all costs incidental thereto. He shall repair or restore all structures and property that may be damaged or disturbed during performance of the work.

The cost of incidental work described in these General Provisions, for which there are no specific Contract Items, shall be considered as part of the overhead cost of doing the work and shall be included in the prices for the various Contract Items. No additional payment will be made therefor.

The Contractor shall provide and maintain such modern plant, tools, and equipment as may be necessary, in the opinion of the Engineer, to perform in a satisfactory and acceptable manner all the work required by this Contract. Only equipment of established reputation and proven efficiency shall be used. The Contractor shall be solely responsible for the adequacy of his plant and equipment, prior approval of the Engineer notwithstanding.

G-1.03 PUBLIC UTILITY INSTALLATIONS AND STRUCTURES

Public utility installations and structures shall be understood to include all poles, tracks, pipes, wires, conduits, house service connections, vaults, manholes, and all other appurtenances and facilities pertaining thereto whether owned or controlled by the City, other governmental bodies or privately owned by individuals, firms, or corporations, and used to serve the public with transportation, traffic control, gas, electricity, telephone, sewerage, drainage, water or other public or private property which may be affected by the work.

The Contract Documents contain data relative to existing public utility installations and structures above and below the ground surface. These data are not guaranteed as to their completeness or accuracy and it is the responsibility of the Contractor to make his own investigations to inform himself

fully of the character, condition and extent of all such installations and structures as may be encountered and as may affect the construction operations.

The Contractor shall protect all public utility installations and structures from damage during the work. Access across any buried public utility installation or structure shall be made only in such locations and by means approved by the Engineer. The Contractor shall so arrange his operations as to avoid any damage to these facilities. All required protective devices and construction shall be provided by the Contractor at his expense. All existing public utilities damaged by the Contractor which are shown on the Plans or have been located in the field by the utility shall be repaired by the Contractor, at his expense, as directed by the Engineer. No separate payment shall be made for such protection or repairs to public utility installations or structures.

Public utility installations or structures owned or controlled by the City or other governmental body which are shown on the Plans to be removed, relocated, replaced or rebuilt by the Contractor shall be considered as a part of the general cost of doing the work and shall be included in the prices bid for the various Contract Items. No separate payment shall be made therefor.

Where public utility installations or structures owned or controlled by the City or other governmental body are encountered during the course of the work, and are not indicated on the Plans or in the Specifications, and when, in the opinion of the Engineer, removal, relocation, replacement or rebuilding is necessary to complete the work under this Contract, such work shall be accomplished by the utility having jurisdiction or such work may be ordered, in writing by the Engineer, for the Contractor to accomplish. If such work is accomplished by the utility having jurisdiction it will be carried out expeditiously and the Contractor shall give full cooperation to permit the utility to complete the removal, relocation, replacement or rebuilding as required. If such work is accomplished by the Contractor, it will be paid for as extra work as provided for in Article 7.02 of the Agreement.

The Contractor shall, at all times in performance of the work, employ approved methods and exercise reasonable care and skill so as to avoid unnecessary delay, injury, damage or destruction of public utility installations and structures; and shall, at all times in the performance of the work, avoid unnecessary interference with, or interruption of, public utility services, and shall cooperate fully with the owners thereof to that end.

All City and other governmental utility departments and other owners of public utilities, which may be affected by the work, will be informed in writing by the Engineer within two weeks after the execution of the Contract or Contracts covering the work. Such notice will set out, in general, and direct attention to, the responsibilities of the City and other governmental

utility departments and other owners of public utilities for such installations and structures as may be affected by the work and will be accompanied by one set of Plans and Specifications covering the work under such Contract or Contracts.

In addition to the general notice given by the Engineer, the Contractor shall give written notice to all City and other governmental utility departments and other owners of public utilities of the location of his proposed construction operations, at least forty-eight (48) hours in advance of breaking ground in any area or on any unit of the work. This can be accomplished by making the appropriate contact with the "Underground Utility Notification Center for Excavators (Call Candy)".

The maintenance, repair, removal, relocation, or rebuilding of public utility installations and structures, when accomplished by the Contractor as herein provided, shall be done by methods approved by the Engineer.

SECTION 2 PLANS AND SPECIFICATIONS

G-2.01 PLANS

The Plans referred to in the Contract Documents bear the general project name and number as shown in the Notice To Bidders.

When obtaining data and information from the Plans, figures shall be used in preference to scaled dimensions, and large scale drawings in preference to small scale drawings.

G-2.02 COPIES FURNISHED TO CONTRACTOR

After the Contract has been executed, the Contractor will be furnished with five sets of paper prints, the same size as the original drawings, of each sheet of the Plans and five copies of the Specifications. Additional copies of the Plans and Specifications, when requested, may be furnished to the Contractor at cost of reproduction.

The Contractor shall furnish each of the subcontractors, manufacturers, and material suppliers such copies of the Contract Documents as may be required for his work.

G-2.03 SUPPLEMENTARY DRAWINGS

When, in the opinion of the Engineer, it becomes necessary to explain more fully the work to be done or to illustrate the work further or to show any changes which may be required, drawings known as Supplementary Drawings, with specifications pertaining thereto, will be prepared by the Engineer and five paper prints thereof will be given to the Contractor.

The Supplementary Drawings shall be binding upon the Contractor with the same force as the Plans. Where such Supplementary Drawings require either less or more than the estimated quantities of work, credit to the City or compensation therefor to the Contractor shall be subject to the terms of the Agreement.

G-2.04 CONTRACTOR TO CHECK PLANS AND DATA

The Contractor shall verify all dimensions, quantities, and details shown on the Plans, Supplementary Drawings, Schedules, Specifications, or other data received from the Engineer, and shall notify him of all errors, omissions, conflicts, and discrepancies found therein. Failure to discover or correct errors, conflicts or discrepancies shall not relieve the Contractor of full responsibility for unsatisfactory work, faulty construction or improper operation resulting therefrom nor from rectifying such conditions at his own expense. He will not be allowed to take advantage of any errors or omissions as full instructions will be furnished by the Engineer, should such errors or omissions be discovered. All schedules are given for the convenience of the Engineer and the Contractor and are not guaranteed to be complete. The Contractor shall assume all responsibility for the making of estimates of the size, kind, and quality of materials and equipment included in work to be done under the Contract.

G-2.05 SPECIFICATIONS

The specifications consist of four parts, the General Provisions, the Technical Specifications, the Special Provisions and the Contract Items. The General Provisions and Technical Specifications contain general requirements which govern the work. The Special Provisions and the Contract Items modify and supplement these by detailed requirements for the work and shall always govern, whenever there appears to be conflict.

G-2.06 INTENT

All work called for in the Specifications applicable to this Contract, but not shown on the Plans in their present form, or vice versa, shall be of like effect as if shown or mentioned in both. Work not specified in either the Plans or in the Specifications, but involved in carrying out their intent or in the complete and proper execution of the work, is required and shall be performed by the Contractor as though it were specifically delineated or described.

The apparent silence of the Specifications as to any detail, or the apparent omission from them of a detailed description concerning any work to be done and materials to be furnished, shall be regarded as meaning that only the best general practice is to prevail and that only material and workmanship of the best quality is to be used, and interpretation of these Specifications shall be made upon that basis.

SECTION 3 WORKING DRAWINGS

G-3.01 SCOPE

The Contractor shall promptly prepare and submit layout, detail and shop drawings to insure proper construction, assembly, and installation of the work using those materials and methods as hereafter specified under the Technical Specifications, Special Provisions and Contract Items.

These drawings shall accurately and distinctly present the following:

- a. All working and erection dimensions.
- b. Arrangements and sectional views.
- c. Necessary details, including complete information for making connections between work under this Contract and work under other Contracts.
- d. Kinds of materials and finishes.
- e. Parts listed and description thereof.

Drawings for mechanical equipment shall present, where applicable, such data as dimensions, weight and performance characteristics. These data shall show conformance with the performance characteristics and other criteria incorporated in the Plans and Specifications.

Each drawing shall be dated and shall contain the name of the project, Division number and description, the technical specifications section number, names of equipment or materials and the location at which the equipment or materials are to be installed. Location shall mean both physical location and location relative to other connected or attached material. The Engineer will return unchecked any submittal which does not contain complete data on the work and full information on related matters.

Stock or standard drawings will not be accepted for review unless full identification and supplementary information is shown thereon in ink or typewritten form.

The Contractor shall review all working drawing submittals before transmitting them to the Engineer to determine that they comply with requirements of the Specifications. Drawings which are incomplete or are not in compliance with the Contract Documents shall not be submitted for processing by the Engineer. The Contractor shall place his stamp of approval on all working drawings submitted to the Engineer to indicate compliance with the above.

G-3.02 APPROVAL

If the working drawings show departures from the Contract requirements, the Contractor shall make specific mention thereof in his letter of submittal; otherwise approval of such submittals shall not constitute approval of the departure. Approval of the drawings shall constitute approval of the subject matter thereof only and not of any structure, material, equipment, or apparatus shown or indicated.

The approval of drawings will be general and shall not relieve the Contractor of responsibility for the accuracy of such drawings, nor for the proper fitting and construction of the work, nor for the furnishing of materials or work required by the Contract and not indicated on the drawings. No work called for by working drawings shall be done until such drawings have been approved by the Engineer.

The procedure in seeking approval of the working drawings shall be as follows:

1. The Contractor shall submit four complete sets of drawings

and other descriptive data together with one copy of a letter of transmittal to the Engineer for approval. The letter of transmittal shall contain the name of the project, contract number, technical specifications section number, the name of the Contractor, a list of drawings with numbers and titles, and any other pertinent information.

2. Drawings or descriptive data will be stamped "Approved", "Approved Subject to Corrections Marked", or "Examined and Returned for Correction" and one copy with a letter of transmittal will be returned to the Contractor.

3. If a drawing or other data is stamped "Approved", the Contractor shall insert the date of approval on five additional copies of the document and transmit the five copies to the Engineer together with one copy of a letter of transmittal containing substantially the same information as described in Instruction 1. above.

4. If a drawing or other data is stamped "Approved Subject to Corrections Marked", the Contractor shall make the corrections indicated and proceed as in Instruction 3., above.

5. If a drawing or data is stamped "Examined and Returned for Correction", the Contractor shall make the necessary corrections and resubmit the documents as set forth in Instruction 1., above. The letter of transmittal shall indicate that this is a resubmittal.

The Contractor shall revise and resubmit the working drawings as required by the Engineer, until approval thereof is obtained.

SECTION 4 MATERIALS AND EQUIPMENT

G-4.01 GENERAL REQUIREMENTS

All materials, appliances, and types or methods of construction shall be in accordance with the Specifications and shall, in no event, be less than that necessary to conform to the requirements of any applicable laws, ordinances, and codes.

All materials and equipment shall be new, unused, and correctly designed. They shall be of standard first grade quality, produced by expert personnel, and intended for the use for which they are offered. Materials or equipment which, in the opinion of the Engineer, are inferior or of a lower grade than indicated, specified, or required will not be accepted.

The quality of Workmanship and Materials entering into the work under this Contract shall conform to the requirements of the pertinent sections, clauses, paragraphs, and sentences, both directly and indirectly applicable thereto, of that part of the Technical Specifications, whether or not direct reference to such occurs in the Contract Items.

Equipment and appurtenances shall be designed in conformity with ANSI, ASME, IEEE, NEMA and other

generally accepted standards and shall be of rugged construction and of sufficient strength to withstand all stresses which may occur during fabrication, testing, transportation, installation, and all conditions of operation. All bearings and moving parts shall be adequately protected against wear by bushings or other approved means and shall be fully lubricated by readily accessible devices. Details shall be designed for appearance as well as utility. Protruding members, joints, corners, gear covers, and the like, shall be finished in appearance. All exposed welds shall be ground smooth and the corners of structural shapes shall be mitered.

Equipment shall be of the approximate dimensions as indicated on the Plans or as specified, shall fit the spaces shown on the Plans with adequate clearances, and shall be capable of being handled through openings provided in the structure for this purpose. The equipment shall be of such design that piping and electrical connections, ductwork, and auxiliary equipment can be assembled and installed without causing major revisions to the location or arrangement of any of the facilities.

Machinery parts shall conform exactly to the dimensions shown on the working drawings. There shall be no more fitting or adjusting in setting up a machine than is necessary in assembling high grade apparatus of standard design. The equivalent parts of identical machines shall be made interchangeable. All grease lubricating fittings on equipment shall be of a uniform type. All machinery and equipment shall be safeguarded in accordance with the safety codes of the ANSI and applicable state and local codes.

G-4.02 MANUFACTURER

The names of proposed manufacturers, suppliers, material, and dealers who are to furnish materials, fixtures, equipment, appliances or other fittings shall be submitted to the Engineer for approval, as early as possible, to afford proper investigation and checking. Such approval must be obtained before shop drawings will be checked. No manufacturer will be approved for any materials to be furnished under this Contract unless he shall be of good reputation and have a plant of ample capacity. He shall, upon the request of the Engineer, be required to submit evidence that he has manufactured a similar product to the one specified and that it has been previously used for a like purpose for a sufficient length of time to demonstrate its satisfactory performance.

All transactions with the manufacturers or subcontractors shall be through the Contractor, unless the Contractor shall request, in writing to the Engineer, that the manufacturer or subcontractor deal directly with the Engineer. Any such transactions shall not in any way release the Contractor from his full responsibility under this Contract.

Any two or more pieces of material or equipment of the same kind, type or classification, and being used for identical types of service, shall be made by the same manufacturer.

G-4.03 REFERENCE TO STANDARDS

Whenever reference is made to the furnishing of materials or

testing thereof to conform to the standards of any technical society, organization or body, it shall be construed to mean the latest standard, code, specification or tentative specification adopted and published at the date of advertisement for proposals, even though reference has been made to an earlier standard, and such standards are made a part hereof to the extent which is indicated or intended.

Reference to a technical society, organization or body may be made in the Specifications by abbreviations, in accordance with the following list:

AASHTO for American Association of State Highway and Transportation Officials (formerly AASHO)
ACI for American Concrete Institute
AGMA for American Gear Manufacturer's Association
AFBMA for Anti-Friction Bearing Manufacturer's Association
AISC for American Institute of Steel Construction
AISI for American Iron and Steel Institute
ANSI for American National Standards Institute
ASCE for American Society of Civil Engineers
ASTM for American Society for Testing and Materials
ASME for American Society of Mechanical Engineers
AWS for American Welding Society
AWWA for American Water Works Association
AWPA for American Wood Preservers Association
CEMA for Conveyor Equipment Manufacturers Association
CIPRA for Cast Iron Pipe Research Association
IEEE for Institute of Electrical and Electronic Engineers
IPCEA for Insulated Power Cable Engineers Association
NEC for National Electrical Code
NEMA for National Electrical Manufacturers Association
SAE for Society of Automotive Engineers
SHBI for Steel Heating Boiler Institute
Fed.Spec. for Federal Specifications
Navy Spec. for Navy Department Specifications
U.L.,Inc. for Underwriters' Laboratories, Inc.

When no reference is made to a code, standard or specification, the Standard Specifications of the ANSI, the ASME, the ASTM, the IEEE, or the NEMA shall govern.

G-4.04 SAMPLES

The Contractor shall, when required, submit to the Engineer for approval typical samples of materials and equipment. The samples shall be properly identified by tags and shall be submitted sufficiently in advance of the time when they are to be incorporated into the work, so that rejections thereof will not cause delay. A letter of transmittal, in duplicate, from the Contractor requesting approval must accompany all such samples.

G-4.05 EQUIVALENT QUALITY

Whenever, in the Contract Documents, an article, material, apparatus, equipment, or process is called for by trade name or by the name of a patentee, manufacturer, or dealer or by reference to catalogs of a manufacturer or dealer, it shall be understood as intending to mean and specify the article, material, apparatus, equipment or process designated, or any

equal thereto in quality, finish, design, efficiency, and durability and equally serviceable for the purposes for which it is intended.

Whenever material or equipment is submitted for approval as being equal to that specified, the decision as to whether or not such material or equipment is equal to that specified shall be made by the Engineer.

Upon rejection of any material or equipment submitted as the equivalent of that specifically named in the Contract, the Contractor shall immediately proceed to furnish the designated material or equipment.

Neither the approval by the Engineer of alternate material or equipment as being equivalent to that specified nor the furnishing of the material or equipment specified, shall in any way relieve the Contractor of responsibility for failure of the material or equipment, due to faulty design, material, or workmanship, to perform the functions required of them by the Specifications.

G-4.06 DELIVERY

The Contractor shall deliver materials in ample quantities to insure the most speedy and uninterrupted progress of the work so as to complete the work within the allotted time. The Contractor shall also coordinate deliveries in order to avoid a delay in, or impediment of, the progress of the work of any related Contractor.

G-4.07 CARE AND PROTECTION

The Contractor shall be solely responsible for properly storing and protecting all materials, equipment, and work furnished under the Contract from the time such materials and equipment are delivered at the site of the work until final acceptance thereof. He shall, at all times, take necessary precautions to prevent injury or damage by water, freezing, or by inclemencies of the weather to such materials, equipment and work. All injury or damage to materials, equipment, or work resulting from any cause whatsoever shall be made good by the Contractor.

The Engineer shall, in all cases, determine the portion of the site to be used by the Contractor for storage, plant or for other purposes. If, however, it becomes necessary to remove and restack materials to avoid impeding the progress of any part of the work or interference with the work to be done by any other Contractor, the Contractor shall remove and restack such materials at his own expense.

G-4.08 TOOLS AND ACCESSORIES

The Contractor shall, unless otherwise stated in the Contract Documents, furnish with each type, kind or size of equipment, one complete set of suitably marked high grade special tools and appliances which may be needed to adjust, operate, maintain, or repair the equipment. Such tools and appliances shall be furnished in approved painted steel cases, properly labeled and equipped with good grade cylinder locks and duplicate keys.

Spare parts shall be furnished as specified.

Each piece of equipment shall be provided with a substantial nameplate, securely fastened in place and clearly inscribed with the manufacturer's name, year of manufacture, serial number, weight and principal rating data.

G-4.09 INSTALLATION OF EQUIPMENT

The Contractor shall have on hand sufficient proper equipment and machinery of ample capacity to facilitate the work and to handle all emergencies normally encountered in work of this character.

Equipment shall be erected in a neat and workmanlike manner on the foundations at the locations and elevations shown on the Plans, unless directed otherwise by the Engineer during installation. All equipment shall be correctly aligned, leveled and adjusted for satisfactory operation and shall be installed so that proper and necessary connections can be made readily between the various units.

The Contractor shall furnish, install and protect all necessary anchor and attachment bolts and all other appurtenances needed for the installation of the devices included in the equipment specified. Anchor bolts shall be as approved by the Engineer and made of ample size and strength for the purpose intended. Substantial templates and working drawings for installation shall be furnished.

The Contractor shall, at his own expense, furnish all materials and labor for, and shall properly bed in non-shrink grout, each piece of equipment on its supporting base that rests on masonry foundations. Grout shall completely fill the space between the equipment base and the foundation.

G-4.10 OPERATING INSTRUCTIONS

The Contractor, through qualified individuals, shall adequately instruct designated employees of the City in the operation and care of all equipment installed hereunder, except for equipment that may be furnished by the City.

The Contractor shall also furnish and deliver to the Engineer three complete sets for permanent files, identified in accordance with Subsection G-3.01 hereof, of instructions, technical bulletins and any other printed matter, such as diagrams, prints or drawings, containing full information required for the proper operation, maintenance, and repair, of the equipment installed and the ordering of spare parts, except for equipment that may be furnished by the City.

In addition to the above three copies, the Contractor shall furnish any additional copies that may be required for use during construction and start-up operations.

G-4.11 SERVICE OF MANUFACTURER'S ENGINEER

The Contract prices for equipment shall include the cost of furnishing a competent and experienced engineer or superintendent who shall represent the manufacturer and shall assist the Contractor, when required, to install, adjust, test and place in operation the equipment in conformity with the Contract Documents. After the equipment is placed in

permanent operation by the City, such engineer or superintendent shall make all adjustments and tests required by the Engineer to provide that such equipment is in proper and satisfactory operating condition, and shall instruct such personnel as may be designated by the City in the proper operation and maintenance of such equipment.

SECTION 5 INSPECTION AND TESTING

G-5.01 GENERAL

The Contractor's attention is hereby directed to Article 3.03 of the Agreement.

Inspection and testing of materials will be performed by the City unless otherwise specified.

For tests specified to be made by the Contractor, the testing personnel shall make the necessary inspections and tests and the reports thereof shall be in such form as will facilitate checking to determine compliance with the Contract Documents. Five copies of the reports shall be submitted and authoritative certification thereof must be furnished to the Engineer as a prerequisite for the acceptance of any material or equipment.

If, in the making of any test of any material or equipment, it is ascertained by the Engineer that the material or equipment does not comply with the Contract, the Contractor will be notified thereof and he will be directed to refrain from delivering said material and equipment, or to remove it promptly from the site or from the work and replace it with acceptable material, without cost to the City.

Tests of electrical and mechanical equipment and appliances shall be conducted in accordance with recognized test codes of the ANSI, ASME, or the IEEE, except as may otherwise be stated herein.

The Contractor shall be fully responsible for the proper operation of equipment during tests and instruction periods and shall neither have nor make any claim for damage which may occur to equipment prior to the time when the City formally takes over the operation thereof.

G-5.02 COSTS

All inspection and testing of materials furnished under this Contract will be performed by the City or duly authorized inspection engineers or inspection bureaus without cost to the Contractor, unless otherwise expressly specified.

The cost of shop and field tests of equipment and of certain other tests specifically called for in the Contract Documents shall be borne by the Contractor and such costs shall be deemed to be included in the contract price.

Materials and equipment submitted by the Contractor as the equivalent to those specifically named in the Contract may be tested by the City for compliance. The Contractor shall reimburse the City for the expenditures incurred in making

such tests on materials and equipment which are rejected for noncompliance.

G-5.03 INSPECTIONS OF MATERIALS

The Contractor shall give notice, in writing to the Engineer, sufficiently in advance of his intention to commence the manufacture or preparation of materials especially manufactured or prepared for use in or as part of the permanent construction. Such notice shall contain a request for inspection, the date of commencement and the expected date of completion of the manufacture or preparation of materials. Upon receipt of such notice the Engineer will arrange to have a representative present at such times during the manufacture as may be necessary to inspect the materials or he will notify the Contractor that inspection will be made at a point other than the point of manufacture, or he will notify the Contractor that inspection will be waived. The Contractor must comply with these provisions before shipping any material. Such inspection shall not release the Contractor from the responsibility for furnishing materials meeting the requirements of the Contract Documents.

G-5.04 CERTIFICATE OF MANUFACTURE

When inspection is waived or when the Engineer so requires, the Contractor shall furnish to him authoritative evidence in the form of Certificates of Manufacture that the materials to be used in the work have been manufactured and tested in conformity with the Contract Documents. These certificates shall be notarized and shall include copies of the results of physical tests and chemical analyses, where necessary, that have been made directly on the product or on similar products of the manufacturer.

G-5.05 SHOP TESTS OF OPERATING EQUIPMENT

Each piece of equipment for which pressure, duty, capacity, rating, efficiency, performance, function, or special requirements are specified shall be tested in the shop of the maker in a manner which shall conclusively prove that its characteristics comply fully with the requirements of the Contract Documents. No such equipment shall be shipped to the work until the Engineer notifies the Contractor, in writing, that the results of such tests are acceptable.

Five copies of the manufacturer's actual test data and interpreted results thereof, accompanied by a certificate of authenticity sworn to by a responsible official of the manufacturing company, shall be forwarded to the Engineer for approval.

The cost of the shop tests and of furnishing manufacturer's preliminary and shop test data of operating equipment shall be borne by the Contractor.

G-5.06 PRELIMINARY FIELD TESTS

As soon as conditions permit, the Contractor shall furnish all labor, materials, and instruments and shall make preliminary field tests of equipment. If the preliminary field tests disclose any equipment furnished under this Contract which does not comply with the requirements of the Contract Documents, the Contractor shall, prior to the acceptance tests, make all changes, adjustments, and replacements required.

TEMPORARY STRUCTURES

G-5.07 FINAL FIELD TESTS

Upon completion of the work and prior to final payment, all equipment and appliances installed under this Contract shall be subjected to acceptance tests as specified or required to prove compliance with the Contract Documents.

The Contractor shall furnish labor, fuel, energy, water and all other materials, equipment, and instruments necessary for all acceptance tests, at no additional cost to the City.

G-5.08 FAILURE OF TESTS

Any defects in the materials and equipment or their failure to meet the tests, guarantees or requirements of the Contract Documents shall be promptly corrected by the Contractor by replacements or otherwise. The decision of the Engineer as to whether or not the Contractor has fulfilled his obligations under the Contract shall be final and conclusive. If the Contractor fails to make those corrections or if the improved materials and equipment, when tested, shall again fail to meet the guarantees or specified requirements, the City, notwithstanding its partial payment for work, and materials and equipment, may reject the materials and equipment and may order the Contractor to remove them from the site at his own expense.

In case the City rejects any materials and equipment, then the Contractor shall replace the rejected materials and equipment within a reasonable time. If he fails to do so, the City may, after the expiration of a period of thirty calendar days after giving him notice in writing, proceed to replace such rejected materials and equipment, and the cost thereof shall be deducted from any compensation due or which may become due the Contractor under this Contract.

The City agrees to obtain other equipment within a reasonable time and the Contractor agrees that the City may use the equipment furnished by him without rental or other charges until the new equipment is obtained.

Materials or work in place that fails to pass acceptability tests shall be retested at the direction of the construction engineer all such retests shall be at the Contractor's expense. The rates charged shall be in accordance with the Department of Public Works current annual inspection contract which is available for inspection at the offices of the Department of Public Works.

G-5.09 FINAL INSPECTION

The procedures for final inspection shall be in accordance with the provisions of Article 4.07 of the Agreement. During such final inspections, the work shall be clean and free from water. In no case will the final estimate be prepared until the Contractor has complied with all the requirements set forth and the Engineer has made his final inspection of the entire work and is satisfied that the entire work is properly and satisfactorily constructed in accordance with the requirements of the Contract Documents.

SECTION 6

G-6.01 GENERAL

All false work, scaffolding, ladders, hoistways, braces, pumping plants, shields, trestles, roadways, sheeting, centering forms, barricades, drains, flumes, and the like, any of which may be needed in the construction of any part of the work and which are not herein described or specified in detail, must be furnished, maintained and removed by the Contractor, and he shall be responsible for the safety and efficiency of such works and for any damages that may result from their failure or from their improper construction, maintenance, or operation.

G-6.02 PUBLIC ACCESS

At all points in the work where public access to any building, house, place of business, public road, or sidewalk would be obstructed by any action of the Contractor in executing the work required by this Contract, the Contractor shall provide such temporary structure, bridges or roadway as may be necessary to maintain public access at all times. At least one lane for vehicular traffic shall be maintained in streets in which the Contractor is working. Street closure permits are required from the Department of Public Works.

The Contractor shall provide suitable temporary bridges, as directed by the Engineer, at street intersections when necessary for the maintenance of vehicular and pedestrian traffic.

Prior to temporarily cutting of access to driveways and garages, the Contractor shall give twelve (12) hours notice to affected property owners. Interruptions to use of private driveways shall be kept to a minimum.

G-6.03 CONTRACTOR'S FIELD OFFICE

The Contractor shall erect, furnish and maintain a field office with a telephone at the site during the entire period of construction. He or an authorized agent shall be present at this office at all times while his work is in progress. Readily accessible copies of both the Contract Documents and the latest approved working drawings shall be kept at this field office.

G-6.04 TEMPORARY FENCE

If, during the course of the work, it is necessary to remove or disturb any fence or part thereof, the Contractor shall, at his own expense, if so ordered by the Engineer, provide a suitable temporary fence which shall be maintained until the permanent fence is replaced. The Engineer shall be solely responsible for the determination of the necessity for providing a temporary fence and the type of temporary fence to be used.

G-6.05 RESPONSIBILITY FOR TEMPORARY STRUCTURES

In accepting the Contract, the Contractor assumes full responsibility for the sufficiency and safety of all temporary structures or work and for any damage which may result from their failure or their improper construction, maintenance, or operation and will indemnify and save harmless the City from

all claims, suits or actions and damages or costs of every description arising by reason of failure to comply with the above provisions.

SECTION 7 TEMPORARY SERVICES

G-7.01 WATER

The Contractor shall provide the necessary water supply at his own expense. He shall, if necessary, provide and lay necessary waterlines from existing mains to the place of using, shall secure all necessary permits and pay for all taps to water mains or hydrants and for all water used at the established rates.

G-7.02 LIGHT AND POWER

The Contractor shall provide, at his own expense, temporary lighting and power facilities required for the proper prosecution and inspection of the work. If, in the opinion of the Engineer, these facilities are inadequate, the Contractor will not be permitted to proceed with any portion of the work affected thereby.

G-7.03 SANITARY REGULATIONS

The Contractor shall prohibit and prevent the committing of nuisances on the site of the work or on adjoining property and shall discharge any employee who violates this rule.

Ample washrooms and toilet facilities and a drinking water supply shall be furnished and maintained in strict conformity with the law by the Contractor for use by his employees.

G-7.04 ACCIDENT PREVENTION

Precautions shall be exercised at all times for the protection of persons and property. The safety provisions of applicable laws, building and construction codes shall be observed. The Contractor shall comply with the U. S. Department of Labor Safety and Health Regulations for construction promulgated under the Occupational Safety and Health Act of 1970 (PL 91-596), and under Section 107 of the Contract Work. Hours and Safety Standards Act (PL 91-54), except where state and local safety standards exceed the federal requirements and except where state safety standards have been approved by the Secretary of Labor in accordance with provisions of the Occupational Safety and Health Act.

G-7.05 FIRST AID

The Contractor shall keep upon the site, at each location where work is in progress, a completely equipped first aid kit and shall provide ready access thereto at all times when men are employed on the work.

G-7.06 HEATING

The Contractor shall provide temporary heat, at his own expense, whenever required on account of work being carried on during cold weather and to prevent freezing of water pipes and other damage to the work.

SECTION 8

LINES AND GRADES

G-8.01 GENERAL

All work done under this Contract shall be constructed in accordance with the lines and grades shown on the Plans, or as given by the Engineer. The full responsibility for keeping alignment and grade shall rest upon the Contractor.

The Engineer will establish bench marks and base line controlling points. Reference remarks for lines and grades as the work progresses will be located to cause as little inconvenience to the prosecution of the work as possible. The Contractor shall so place excavation and other materials as to cause no inconvenience in the use of the reference marks provided. He shall remove any obstructions placed by him contrary to this provision.

G-8.02 SURVEYS

The Contractor shall furnish and maintain, at his own expense, stakes and other such materials, and give such assistance, including qualified helpers, as may be required by the Engineer for setting reference marks. The Contractor shall check such reference marks by such means as he may deem necessary and, before using them, shall call the Engineer's attention to any inaccuracies. The Contractor shall, at his own expense, establish all working or construction lines and grades as required from the reference marks set by the Engineer, and shall be solely responsible for the accuracy thereof. He shall, however, be subject to the check and review of the Engineer.

The Contractor shall keep the Engineer informed a reasonable time in advance as to his need for line and grade reference marks, in order that they may be furnished and all necessary measurements made for record and payment with the minimum of inconvenience to the Engineer or of delay to the Contractor.

It is the intention not to delay the work for the establishment of reference marks but, when necessary, working operations shall be suspended for such reasonable time as the Engineer may require for this purpose.

G-8.03 SAFEGUARDING MARKS

The Contractor shall safeguard all points, stakes, grade marks, monuments and bench marks made or established on the work, bear the cost of reestablishing them if disturbed, and bear the entire expense of rectifying work improperly installed due to not maintaining or protecting or to removing without authorization such established points, stakes and marks.

The Contractor shall safeguard all existing and known property corners, monuments and marks adjacent to but not related to the work and, if required, shall bear the cost of reestablishing them if disturbed or destroyed.

G-8.04 DATUM PLANE

All elevations indicated or specified refer to the Mean Sea Level Datum of the U.S.C. & G.S. (N.O.S.) which is 0.80 feet above the Mean Low Water Datum of the U. S. Army

Corps of Engineers.

SECTION 9 ADJACENT STRUCTURES AND LANDSCAPING

G-9.01 RESPONSIBILITY

The responsibility for removal, replacement, relocation, repair, rebuilding or protection of all public utility installations, including poles, tracks, pipes, wires, conduits, house service connections, vaults, manholes, sewers, traffic control and fire alarm signal circuit installations and other appurtenances and facilities shall be in accordance with G-1.02 and G-1.03.

The Contractor shall also be entirely responsible and liable for all damage or injury as a result of his operations to all other adjacent public and private property, structures of any kind and appurtenances thereto met with during the progress of the work. The cost of protection, replacement in their original locations and conditions or payment of damages for injuries to such adjacent public and private property and structures affected by the work, whether or not shown on the Plans, and the removal, relocation, and reconstruction of such items called for on the Plans or specified shall be included in the various Contract Items and no separate payment will be made therefor. Where such public and private property, structures of any kind and appurtenances thereto are not shown on the Plans and when, in the opinion of the Engineer, removal or relocation and reconstruction is necessary to avoid interference with the work, payment therefor will be made as provided for extra work in Article 7.02 of the Agreement.

G-9.02 PROTECTION OF TREES

All trees and shrubs shall be adequately protected by the Contractor with boxes or otherwise and, within the City of Tampa, in accordance with ordinances governing the protection of trees. No excavated materials shall be placed so as to injure such trees or shrubs. Trees or shrubs destroyed by negligence of the Contractor or his employees shall be replaced by him with new stock of similar size and age, at the proper season, and at the sole expense of the Contractor.

Beneath trees or other surface structures, where possible, pipelines may be built in short tunnels, backfilled with excavated materials, except as otherwise specified, or the trees or structures carefully supported and protected from damage.

The City may order the Contractor, for the convenience of the City, to remove trees along the line of trench excavation. If so ordered, the City will obtain any permits required for removal of trees. Such tree removal ordered shall be paid for under the appropriate Contract Items.

G-9.03 LAWN AREAS

Lawn areas shall be left in as good condition as before the starting of the work. Where sod is to be removed, it shall be carefully removed and later replaced, or the area where sod has been removed shall be restored with new sod in the

manner described in the Technical Specifications section.

G-9.04 RESTORATION OF FENCES

Any fence, or part thereof, that is damaged or removed during the course of the work shall be replaced or repaired by the Contractor and shall be left in as good a condition as before the starting of the work. The manner in which the fence is repaired or replaced and the materials used in such work shall be subject to the approval of the Engineer. The cost of all labor, materials, equipment, and work for the replacement or repair of any fence shall be deemed included in the appropriate Contract Item or Items, or if no specific Item is provided therefor, as part of the overhead cost of the work, and no additional payment will be made therefor.

SECTION 10 PROTECTION OF WORK AND PUBLIC

G-10.01 TRAFFIC REGULATIONS

The Contractor shall arrange his work to comply with Article G-6.02. The work shall be done with the least possible inconvenience to the public and to that end the work may be confined by the Engineer to one block at a time.

G-10.02 BARRIERS AND LIGHTS

During the prosecution of the work, the Contractor shall put up and maintain at all times such barriers, and lights, as will effectually prevent accidents. The Contractor shall provide suitable barricades, red lights, "danger" or "caution" or "street closed" signs and watchmen at all places where the work causes obstructions to the normal traffic or constitutes in any way a hazard to the public. Such barriers and signs shall be constructed to State of Florida Department of Transportation standards and placed as recommended by the Traffic Division of the City's Department of Public Works.

No open fires will be permitted.

G-10.03 SMOKE PREVENTIONS

The Contractor shall use hard coal, coke, oil or gas as fuel for equipment generating steam. A strict compliance with ordinances regulating the production and emission of smoke will be required.

G-10.04 NOISE

The Contractor shall eliminate noise to as great an extent as practicable at all times. Air compressing plants shall be equipped with silencers and the exhaust of all gasoline motors or other power equipment shall be provided with mufflers. In the vicinity of hospitals and schools, special care shall be used to avoid noise or other nuisances. The Contractor shall strictly observe all local regulations and ordinances covering noise control.

Except in the event of an emergency, no work shall be done between the hours of 7:00 p.m. and 7:00 a.m., or on Sundays.

If the proper and efficient prosecution of the work requires operations during the night, the written permission of the Engineer shall be obtained before starting such items of the work.

**SECTION 13
CLEANING**

G-10.05 ACCESS TO PUBLIC SERVICES

Neither the materials excavated nor the materials or plant used in the construction of the work shall be so placed as to prevent free access to all fire hydrants, valves or manholes.

G-10.06 DUST PREVENTION

The Contractor shall prevent dust nuisance from his operations or from traffic by keeping the streets sprinkled with water at all times.

G-10.07 PRIVATE PROPERTY

The Contractor shall so conduct the work that no equipment, material, or debris will be placed or allowed to fall upon private property in the vicinity of the work unless he shall have obtained the owner's written consent thereto and shall have shown this consent to the Engineer.

**SECTION 11
SLEEVES AND INSERTS**

G-11.01 COORDINATION

When the Contract requires the placing of conduits, saddles, boxes, cabinets, sleeves, inserts, foundation bolts, anchors, and other like work in floors, roofs, or walls of buildings and structures, they shall be promptly installed in conformity with the construction program. The Contractor who erects the floors, roofs, and walls shall facilitate such work by fully cooperating with the Contractors responsible for installing such appurtenances. The Contractor responsible for installing such appurtenances shall arrange the work in strict conformity with the construction schedule and avoid interference with the work of other contractors.

G-11.02 OPENINGS TO BE PROVIDED

In the event timely delivery of sleeves and other materials cannot be made and to avoid delay, the affected Contractor may arrange to have boxes or other forms set at the locations where the appurtenances are to pass through or into the floors, roofs, walls, or other work. Upon the subsequent installation of these appurtenances, the Contractor erecting the structure shall fill around them with materials as required by the Contract. The necessary expenditures incurred for the boxing out and filling in shall be borne by the Contractor or Contractors required to furnish the sleeves and inserts. Formed openings and later installation of sleeves will not be permitted at locations subject to hydrostatic pressure.

**SECTION 12
CUTTING AND PATCHING**

G-12.01 GENERAL

The Contractor shall do all cutting, fitting, or patching of his portion of the work that may be required to make the several parts thereof join and coordinate in a manner satisfactory to the Engineer and in accordance with the Plans and Specifications. The work must be done by competent workmen skilled in the trade required by the restoration.

G-13.01 DURING CONSTRUCTION

During construction of the work, the Contractor shall, at all times, keep the site of the work and adjacent premises as free from material, debris, and rubbish as is practicable and shall remove the same from any portion of the site if, in the opinion of the Engineer, such material, debris, or rubbish constitutes a nuisance or is objectionable.

The Contractor shall remove from the site all of his surplus materials and temporary structures when no further need therefor develops.

G-13.02 FINAL CLEANING

At the conclusion of the work, all erection plant, tools, temporary structures and materials belonging to the Contractor shall be promptly taken away, and he shall remove and promptly dispose of all water, dirt, rubbish or any other foreign substances.

The Contractor shall thoroughly clean all equipment and materials installed by him and shall deliver such materials and equipment undamaged in a bright, clean, polished, and new appearing condition.

**SECTION 14
MISCELLANEOUS**

G-14.01 PROTECTION AGAINST SILTATION AND BANK EROSION

The Contractor shall arrange his operations to minimize siltation and bank erosion on construction sites and on existing or proposed watercourses and drainage ditches.

G-14.02 EXISTING FACILITIES

The work shall be so conducted to maintain existing facilities in operation insofar as is possible. Work shall be scheduled to minimize bypassing during construction. Requirements and schedules of operations for maintaining existing facilities in service during construction shall be as described in the Special Provisions.

G-14.03 USE OF CHEMICALS

All chemicals used during project construction or furnished for project operation, whether herbicide, pesticide, disinfectant, polymer, reactant or of other classification, must show approval of either EPA or USDA. Use of all such chemicals and disposal of residues shall be in strict conformance with instructions.

SUPPLEMENTARY GENERAL PROVISIONS

1.0 GENERAL:

- 1.1 This Section sets forth modifications to the "General Provisions" of the Contract Documents which are referred to as Specifications, General Provisions.
- 1.2 Paragraph numbers and titles used herein refer to similarly numbered and titled articles in the General Provisions.
- 1.3 Only those paragraphs contained herein shall be assumed to be modified. Paragraphs not appearing herein shall apply as written in the General Provisions.
- 1.4 Any portion of the General Provisions, whether or not modified herein, may be further modified in Special Conditions and in the Instructions to Bidders of these Specifications.
- 1.5 Where the Supplementary General Provisions, Special Conditions and Instructions to Bidders conflict with the General Provisions, the Supplementary General Provisions, Special Conditions and the Instructions to Bidders shall take precedence.

2.0 MODIFICATIONS TO THE GENERAL PROVISIONS AS FOLLOWS:

2.1 SECTION 1 SCOPE AND INTENT

G-1.02 WORK INCLUDED

The first paragraph shall be deleted in its entirety and replaced by the following paragraph:

"The Contractor shall furnish all labor, superintendence, materials, plant, power, light, heat, fuel, water, tools, appliances, equipment, supplies, and other means of construction necessary or proper for performing and completing the work. He shall obtain all required permits. He shall perform and complete the work in the manner best calculated to promote rapid construction consistent with safety of life and property and to the satisfaction of the Engineer, and in strict accordance with the Contract Documents. The Contractor shall clean up the work and maintain it during and after construction, until incidental thereto. He shall repair or restore all during performance of the work."

2.2 SECTION 3 WORKING DRAWINGS

- a. Change to read as follows:

SECTION 3 SHOP DRAWINGS

- b. Replace the existing paragraphs in their entirety with the following paragraphs:

G-3.01 SCOPE

Shop drawings, schedules, etc., shall be submitted to the Engineer and/or Architect in quadruplet, accompanied by a letter of transmittal. Subcontractors and suppliers shall submit shop drawings and make requests for approvals through their respective prime Contractors.

The drawings shall be numbered consecutively and shall accurately and distinctly present the following:

- (1) Names of equipment or materials, and the locations at which the equipment or materials are to be installed in the work.

- (2) All working and erection dimensions.
- (3) Arrangement and sectional views.
- (4) Necessary details, including complete information for making connections between work under this contract and work under other contracts.
- (5) Kinds of materials and finishes.
- (6) Parts list and description thereof.

The Engineer and/or Architect may decline to consider any shop drawing that does not contain complete data on the work and full information of related matters.

Fax submittals will not be reviewed.

G-3.02 APPROVAL:

Shop drawings shall be examined by the Contractor prior to his transmitting them to the Engineer and/or Architect. Shop drawings submitted to the Engineer and/or Architect shall bear the Contractor's stamp of approval evidencing that he has examined and checked each drawing and that he has found said drawings to be in accordance with the Contract requirements. Any drawings submitted without this stamp will not be considered by the Engineer and/or Architect and will be returned to the Contractor for re- submission.

If the shop drawings show departures from the Contract requirements, the Contractor shall make specific mention thereof in his letter of submittal and the following shall be submitted:

- (1) Each request shall include a complete description of the proposed substitute and the name of the material or equipment for which it is to be substituted.
- (2) Furnish drawings, cut, manufacturer's printed specifications, performance and test data and any other data or information necessary for a complete evaluation of both the item specified and the proposed substitute item.

Approval of the drawings shall constitute approval of the subject matter thereof only and not of any structure, material, equipment or apparatus shown or indicated.

Approval of the drawings shall be general and shall not relieve the Contractor of responsibility for the accuracy of such drawings, nor for the quantities of materials and equipment, nor for the proper fitting and construction of the work, nor for the furnishing of materials, tools, equipment, etc., required by this contract and not indicated on the drawings.

No work called for by Shop Drawings shall be done until the said drawings have been approved by the Engineer and/or Architect.

The Contractor shall revise and resubmit the shop drawings as required by the Engineer and/or Architect until approval thereof is obtained.

The City shall retain four (4) copies of all submittals unless the Engineers and/or Architect makes a specific request for additional copies.

<u>Items</u>	<u>Submittals</u>	<u>*Approval</u>
All trade	Fourteen (14) Days	Fourteen (14) Days

*From date of receipt of submittal.

Delays on account of tardy or untimely submittals will not be considered as causes of extension of time of the Contract or increases to the Contract Sum.

G-3.03 JOB SITE:

One (1) copy of all approved submittals SHALL BE available at the Contractor's Office at the job site.

2.3 SECTION 4 MATERIALS AND EQUIPMENT

G-4.01 GENERAL REQUIREMENTS

In the first paragraph, second line, delete the word "specifications" and substitute the words "Contract Documents".

G4.03 REFERENCE TO STANDARDS

The following paragraph shall be added in its entirety:

"Compliance with the Standard Building Code, latest edition, and all local electrical and plumbing codes shall be required. In the event of a conflict in code requirements, the most stringent code or standard shall apply."

G-4.05 EQUIVALENT QUALITY

Add the following sentence to paragraph two: "Any professional fees associated with shop drawing review of materials or equipment submitted for approval as equivalent to that specified shall be borne by the Contractor.

2.4 SECTION 5 INSPECTION AND TESTING

G-5.06 PRELIMINARY FIELD TESTS

G-5.07 FINAL FIELD TEST

A. Add the following sentence to BOTH of the above paragraphs:

The Contractor shall provide, at NO EXTRA COST to the City, ALL labor, tools, equipment, materials, etc., for the Engineer and/or Architect to make any field test that may be required in the judgment of the Engineer and/or Architect.

2.5 SECTION 6 TEMPORARY STRUCTURES

G-6.03 CONTRACTOR'S FIELD OFFICE

A. Delete this paragraph G-6.03 in its entirety.

2.6 SECTION 7 TEMPORARY SERVICES

G-7.07 TELEPHONE

The Contractor shall furnish the Engineer with a telephone number(s) by which the Engineer may contact the site.

2.7 SECTION 14 MISCELLANEOUS

G-14.04 USE OF EXPLOSIVES:

Explosives will not be used on the work except when authorized by the Engineer and/or Architect. The use of same, if authorized, shall conform to laws or ordinances which may pertain to the use of same and the utmost care will be exercised by the Contractor so as not to endanger life or property. The Contractor will assume full responsibility in connection with use of any explosives even though authorized. Explosives will not be stored within the City limits.

G-14.05 OWNERSHIP OF MATERIALS:

The removal of any underground and surface structures as required shall be performed in a careful manner to permit salvaging of as much material, such as pipe and brick, also broken section of sidewalk, as practical for use in repair and maintenance of City-owned facilities.

Such acceptable salvaged material remains the property of the City and shall be placed in stock piles so as not to interfere with new construction work but accessible for loading and hauling by the City or by the Contractor within the free haul limit of six (6) miles. The Engineer and/or Architect shall direct the Contractor as to the location of stockpile.

The paving material, such as vitrified brick, asphalt block and other paving materials removed from the excavated areas and suitable for reuse but not reused in the work, shall also be considered the property of the City. The handling of such materials shall be as set forth elsewhere in the Specifications or Special Provisions.

G-14.06 NOTICE OR SERVICE THEREOF:

All notices, which shall include demands, instructions, requests, approvals and claims, shall be in writing.

Any notice to or demand upon the Contractor shall be sufficiently given if delivered to the office of the Contractor specified in the bid (or to such other office as the Contractor may, from time to time, designate to the City in writing), or if deposited in the United States mail in a sealed, postage-prepaid envelope, or delivered, with charges case addressed to such office.

All notices required to be delivered to the City shall, unless otherwise specified in writing to the Contractor, be delivered to Contract Administration Department – Construction Management Division, 3808 East 26th Avenue, Tampa, Florida 33605, and any notice to or demand upon the City shall be sufficiently given if delivered to the office of the said Engineer and/or Architect, or if deposited in the United States mail in a sealed, postage- prepaid envelope, or delivered with charges prepaid to any telegraph company for transmission, in each case addressed to said Engineer and/or Architect or to such other representative of the City or to such other address as the City may subsequently specify in writing to the Contractor or to its representative at the construction site for such purposes.

Any such notice or demand shall be deemed to have been given or made as of the time of actual delivery or (in the case of mailing) when the same should have been received in due course of post or (in the case of telegram) at the time of actual receipt, as the case may be.

G-14.07 REQUIREMENTS FOR CONTROL OF THE WORK:

Prior to the start of the work included in this contract, a Preconstruction Conference will be held by the Engineer and/or Architect to be attended by the Contractor and representatives of the various utilities and others for the purpose of establishing a schedule of operations which will coordinate the work to be done under this contract with all related work to be done by others within the limits of the project. The Contractor shall be prepared for this meeting and shall present a comprehensive construction schedule for all items of work to be accomplished by him,

which will be used as the basis for the development of an overall operational schedule and a list of subcontractors to be used on this work.

All items of work on this contract shall be coordinated so that progress on each related work item will be continuous from week to week. The progress of the work will be reviewed by the Engineer and/or Architect at the end of each week, and if the progress on any item of work during that week is found to be unsatisfactory, the Contractor shall be required to adjust the rate of progress on that item or other items as directed by the Engineer and/or Architect.

The Contractor shall conduct his operations in such a manner as will result in a minimum of inconvenience to occupants of adjacent homes and business establishments and shall provide temporary access as directed or as conditions in any particular location may require.

G-14.08 WORK DIRECTIVE CHANGE:

"A Work Directive Change is a written directive to the Contractor, issued on or after the date of the execution of the Agreement, and signed by the Engineer on behalf of the City, ordering an addition, deletion or revision in the work, or responding to an emergency. A Work Directive Change will not change the contract price or the time for completion, but is evidence that the parties expect that the change directed or documented by a Work Directive Change will be incorporated in a subsequently issued Change Order following negotiations by the parties as to its effect, if any, on the contract price or the time for completion. "Without invalidating the Agreement, additions, deletions or revisions in the Work may, at any time or from time to time, be authorized by a Change Order or a Work Directive Change. Upon receipt of any such document, the Contractor shall promptly proceed with the work involved."

G-14.10 EROSION AND SEDIMENT CONTROL:

During construction, the Contractor shall provide adequate erosion and sediment controls to prevent adverse effects to the environment and public and private property. He shall construct and maintain control structures necessary to prevent erosion and sediment. He shall conduct and schedule construction operations to avoid, prevent, and minimize erosion and sediment. He shall comply with City, County, State, and Federal codes, laws, and regulations and the plans and specifications for this project pertaining to erosion and sediment prevention and control.

At the Preconstruction Conference, the Contractor shall present a plan for erosion and sediment prevention and control. This plan shall include the operations methods, also temporary and permanent control measures and structures to be used on this project.

G-14.12 PROJECT SIGNS:

The Contractor shall furnish and install, as directed by the Engineer and/or Architect, a project sign of design, size, color, etc., as per drawing page SIGN-1.

G-15.0 NOTIFICATION TO CONTRACTORS:

All Contractors working in City of Tampa buildings and facilities that contain ACM will be provided with a written notice, including contract custodial firms. The notice when applicable will advise Contractors about the possibility of encountering ACM while working for the City and will require Contractors to become familiar with locations of ACM within their work areas. The Contractor Notice shall include the name and phone number of the designated Building Asbestos Contact Person assigned to that building/facility. This notice is provided in Appendix C.

Appendix C

Contractor Notification Requirements

Asbestos-Containing Material (ACM) may be present in the facility. The presence of ACM does not necessarily mean that a hazard exists; however, a hazard may be created when ACM is disturbed and asbestos fibers become airborne. The best way to maintain a safe environment is to avoid the disturbance of ACM.

It is possible that you may encounter ACM while working in the facility. On the bulletin board, there is a summary of known locations of ACM in that building. The summary may or may not be all inclusive. Therefore, workers must exercise caution and be watchful for materials that might contain asbestos. Avoid disturbing ACM or suspected ACM as you carry out your work.

If your work necessitates the disturbance of ACM you shall take whatever precautions that are necessary to protect human health and the environment from asbestos fibers. At minimum, you will comply with all Federal, State, and Local responsible for assuring that you are medically certified, trained, and equipped with the proper personal protective devices for safe handling of ACM. You must notify the designated Building Asbestos Contact Person before disturbing any asbestos-containing materials in City-Owned buildings. The designated Building Asbestos Contact Person is listed on the bulletin board with the asbestos location summary.

If you need additional information regarding ACM in a particular building or would like to see a copy of the Operations and Maintenance Plan, contact the Building Asbestos Contact Person responsible for the building for which you will be working.

Comply with all regulatory requirements for removal and disposal.

SPECIAL CONDITIONS

1.0 PRECONSTRUCTION BRIEFING:

The Contractor, upon receiving notice that he has been awarded the contract for the construction of the project, shall make an appointment with the Engineer and/or Architect for said briefing. The Contractor shall bring to this meeting the following:

1. Contract Documents not yet submitted.
2. A detailed Job Progress Schedule.
3. Samples, questions, etc., he feels necessary.
4. List of subcontractors.

Failure to bring the above items to the meeting will result in cancellation of meeting. Once items have been submitted, meeting will be rescheduled by the City. Site access and commencement of work will not be allowed during period between meetings.

Contractor shall have representatives present at meeting that are familiar with, and conversant on, the scope of the work and Contract Document requirements. Failure to have such persons present will also result in cancellation and rescheduling of meeting until such a time when condition is corrected.

Elapsed time as a result of the Contractor's failure to comply with above will not result in an extension of contract time.

2.0 SITE REVIEW:

Before submitting Proposals, Bidders shall carefully examine the entire site of the proposed work and adjacent premises and the various means of approach and access to the site, and make all necessary investigations to inform themselves thoroughly as to the facilities for delivering, placing and operating the necessary construction equipment, and for delivering and handling materials at the site, and inform themselves thoroughly as to all difficulties involved in the completion of all the work in accordance with the Contract Documents.

The Contractor shall immediately, upon entering project site for the purpose of beginning work, review project site with the Engineer and/or Architect for the purpose of selecting area(s) to place materials for storage.

The Contractor must exercise proper precaution to verify all figures shown or indicated on the drawings, all existing trees, paved areas; utilities, etc., shall be located before beginning any work, and he shall be held responsible for any error resulting from his failure to exercise such precaution.

2.1 LAYING OUT WORK:

The Contractor shall locate all general reference points and take necessary action to prevent their destruction; lay out his own work and be responsible for all lines, elevations, measurements, grading, trenching, backfilling, utilities and other work to be executed by him for a complete project under this contract.

The Contractor shall lay out all work and have final approval by the Engineer and/or Architect before installation begins. Contractor shall be held responsible for any error resulting from his failure to exercise such approval. Said errors shall be corrected by the Contractor at NO EXTRA COST to the City.

The Contractor shall coordinate with the Parks Department and shall identify each and every tree to remain prior to the start of work. The specific trees to remain shall be approved by the Parks Department.

The final location of all work to be performed shall be made jointly by the Engineer and/or Architect and the Contractor at the project site.

3.0 SAFETY AND HEALTH STANDARDS:

The performance of all construction under this contract shall conform to ALL Local, State, Federal Occupation Safety and Health Act Standards.

At the end of each work day, all work areas shall be left in a safe condition. Barricades and/or warning devices shall be provided for at any open excavations or barriers on the project site.

The Contractor's attention is directed to paragraphs Article 3.07 and Article 12.03 of the Agreement, and paragraph G-7.04 of the General Provisions.

4.0 INFORMATION FOR COLOR SCHEDULES:

Not later than thirty (30) calendar days after authorization to proceed with contract work, the Contractor shall submit to the Engineer and/or Architect the names of all manufacturers and trade names for all materials involving selection based upon color or texture or other design appearance features which are to be used in this project. Where samples are necessary for such selection, furnish same.

If such information is not furnished by Contractor within thirty (30) day period, the Engineer and/or Architect will select colors and textures from products named in the Contract Documents.

5.0 RESPONSIBILITY OF CONTRACTOR:

The Contractor shall take all necessary precautions to protect all project surfaces and adjoining areas from mechanical damage from tools, equipment, materials, supports, etc., and shall provide adequate protection from leaking lubricants or fluids from his equipment.

Damage to said project surfaces and adjoining areas caused by a lack of protection or negligence by the Contractor shall be repaired and/or replaced at NO EXTRA COST to the City and to the full satisfaction of the Engineer and/or Architect.

The Contractor and all subcontractors are charged with the protection of the work and property, but the final responsibility for these provisions rests with the Contractor who shall take complete charge of the project site from start to finish of work.

The Contractor shall take particular precautions to protect existing trees and plant material. All trees and other plant material to remain shall be marked by the City prior to start of work.

Excavation, earthwork or sitework within the drip line of existing trees shall be done either manually or by methods approved by the City of Tampa Parks Department.

If the Contractor damages any tree or plant material in any way he shall be required to replace the damaged tree or plant material as follows:

1. Trees
 - a. Replace a 6" caliper or less with a 6" caliper of the same species.
 - b. Replace a 7"-10" caliper with two (2) 6" caliper of the same species.
 - c. Replace a 10"-15" caliper with three 6" caliper of the same species.
 - d. Replace a 16"-20" caliper with five (5) 6" caliper of the same species.

e. Replace a 21"-36" caliper with ten (10) 6" caliper of the same species.

2. Plant Material

Replace any damaged plant material with an equal size and quantity of the same material.

The replaced trees and plant material shall be guaranteed by the Contractor for a period of six (6) months.

6.0 COORDINATION WITH N.I.C. ITEMS:

The Contractor shall give to the Engineer and/or Architect, in writing, a time schedule for the installation or removal of all N.I.C. items at the beginning of the project. Failure of the Contractor to supply the Engineer and/or Architect with said schedule shall not be used for reason of time extension by the Contractor.

7.0 ELECTRICAL SERVICE LOCATION:

The Contractor shall verify and coordinate the service location with the local power company and the Engineer and/or Architect.

The Contractor shall coordinate with the local power company and shall include in his bid all costs for electrical service to work area(s) under this Contract, including but not limited to new service, connections from existing and/or new service and all required labor, equipment, materials etc. and all other associated electrical work.

8.0 SCHEDULING:

The Contractor shall provide the City with a detailed schedule prior to start of work.

The schedule shall be a fully developed, horizontal bar-chart type Contractor's construction schedule. Provide a separate time bar for each significant construction activity. Provide a continuous vertical line to identify the first working day of each week. Use the same breakdown of units of the Work as indicated in the "Schedule of Values".

Unless otherwise directed or approved, prepare schedule on a single 8-1/2" X 14" sheet of plain bond white paper.

Secure time commitments for performing critical elements of the Work from parties involved. Coordinate each element on the schedule with other construction activities; include minor elements involved in the sequence of the Work. Show each activity in proper sequence. Indicate graphically the sequences necessary for completion of related portions of the Work.

Contractor shall also prepare schedule in accordance with applicable portions of Section 4.02 of the Agreement.

9.0 ASSIGNMENT OF CONTRACT: Not applicable.

10.0 WORKMANSHIP AND MATERIALS:

Workmanship and materials shall be installed in accordance with accepted standards of the specific trade, as defined by the applicable recognized trade association(s). In the event of a conflict between these trade standards and the Contract Documents, the conflict shall be brought to the Engineer's and/or Architect's attention writing and the final decision shall be made by the Engineer and/or Architect.

12.0 ON SITE RECYCLABLE CRITERIA:

Contractor shall make reasonable attempts to recycle and/or salvage at least 50% of non-hazardous construction and demolition debris. Contractor shall develop and implement a Construction Waste Management Plan that identifies the materials that are to be diverted from disposal by weight or volume and be directed to a recycling facility. Specific area(s) on the construction site shall be designated for collection and tracking of the designated materials as needed. Location of the recycling area on site shall be coordinated with the project owner's representative on site prior to construction start. The intent of this section is to encourage recycling where practical in the context of the scope of work.

Contractor shall submit the following but not limited to items related to this section:

1. Provide a submittal of the contractor's plan of action to recycle
2. Contractor is required to document all activities with above requirements and provide to the city upon request items that are recyclable, documentation of the quantity of material disposed at a recycling facility.

SPECIFIC PROVISIONS

SP-1.G Scope

The work included under these Contract Documents is described in the Proposal.

The Contractor shall furnish all labor, materials and equipment for the accomplishment of all work as described in the Specifications, as shown on the Plans and as directed by the Engineer in accordance with the obvious or expressed intent of the Contract.

SP-2 Permits

The City will obtain permits required from any State or County agencies having jurisdiction over the roadways and for any railroad or highway crossings shown on the Plans. The Contractor shall be required to comply with all provisions of such permits regarding workmanship, schedules, maintenance of traffic, and notification of starting construction, pavement removal and replacement and other conditions under which the permit is issued.

The City will obtain the Florida Department of Environmental Protection (FDEP) Permit for Constructing a Domestic Wastewater Collection/Transmission System, currently administered by Hillsborough County Environmental Protection Commission (EPC).

The Contractor shall obtain all permits required to comply with Maintenance of Traffic.

The Contractor shall have in his possession the proper license to perform the work before submittal of his bid and shall obtain any required City/County building permits and shall obtain and pay for all other licenses and authorizations required for the prosecution of the work, including the cost of all work performed in compliance with the terms and conditions of such permits, licenses and authorizations, whether by himself or others.

City/County building permit fees will be paid by the City. Right-of-way and maintenance of traffic permit fees shall be paid by the Contractor.

The Contractor shall require all subcontractors to be currently licensed by the City to perform the proposed work in their respective fields and to obtain permits for the execution of said work. All work shall be performed in accordance with the licenses, permits and the requirements of the current Building and Construction Regulations Chapter of the City of Tampa Code.

The Contractor is responsible to schedule and coordinate with the City Construction Services Division of the Department of Housing and Development Coordination all required inspections and tests for all phases of work to obtain final approval thereof.

The Contractor is encouraged to contact the City's Construction Services Division prior to commencement of work to ascertain their respective requirements.

SP-5 Working Drawings

Prior to performing any work requiring working drawings, as specified on the Plans and in the Workmanship and Materials Sections, the Contractor shall submit the working drawings in accordance with the General Provisions section headed "Working Drawings."

SP-6 Environmental Protection

The Contractor will be held liable for the violation of any and all environmental regulations. Violation citations carry civil penalties and in the event of willful violation, criminal penalties. The fact that the permits are issued to the City does not relieve the Contractor in any way of his environmental obligations and responsibilities.

SP-9 Coordination and Cooperation

In performing work under this Contract, the Contractor shall coordinate his work with that of any adjacent contractors for the City, and others, and cooperate with them in every reasonable way, to the end that there shall be the minimum practicable interference with their operations.

SP-10 Connections Between Construction

The Contractor shall provide an approved type masonry bulkhead, spigot plug, bell cap, or standard pipe plug in the sewer, manhole, junction chamber, pipe stub or other location to provide for terminating construction when the work is performed in phases and the connecting phase is not complete.

The Contractor shall remove any such bulkhead or plug encountered when connecting to previously completed work.

The cost of furnishing and removing bulkheads and plugs shall be included in the various classified unit price Contract Items for pipe lines, or in the total Lump Sum Price, as applicable, and no separate payment will be made therefor.

SP-12 Releasing Facilities for Use

It is the intent of these Specifications that all newly constructed sewers and appurtenant facilities be placed in service as rapidly as an integrated portion of the facilities can be constructed, inspected and accepted by the Engineer. Acceptance or use by the City of any portion of the facilities prior to final acceptance shall not relieve the Contractor of any responsibilities, regarding such facilities, included in the Contract.

SP-13 Material and Equipment Approval

The Contractor shall not enter into any subcontracts, or place any order, for the furnishing of any material or equipment until he has received the Engineer's written approval of the manufacturers.

SP-14 Contractor Emergency Response Time

The Contractor must be available to service emergency calls seven (7) days a week, twenty-four (24) hours a day. The response time for emergency calls shall be within two (2) hours. A contact person and telephone number shall be provided to the Engineer for such purposes.

SP-15 Contractor's Field Office

Delete Article G-6.03 Contractor's Field Office from GENERAL PROVISIONS. The Contractor or an authorized agent shall be present at all times while his work is in progress. Readily accessible copies of both the contract documents and the latest approved working drawings shall be kept at the job site.

SP-16.PS Salvage

All salvageable material, as determined by the Engineer, shall be removed by the Contractor and shall remain the property of the City.

All such salvaged items shall be removed by the Contractor, delivered, and unloaded at a location within the Department's service area, as directed by the Engineer. The Contractor shall include all necessary labor and equipment to unload the materials at a location designated by the City. The cost of removing, disposing, delivering, and unloading as salvage items of pipe and appurtenances shall be included in the various Contract Unit Prices or the Lump Sum Price, as applicable, and no separate payment will be made therefor.

SP-17 Sequence of Operations

The Contractor shall develop with the Engineer a complete schedule of operations which, in the opinion of the Engineer, will permit use of the facility at the earliest possible date.

Taking over of parts of the work for operation before completion of the entire project shall not relieve the Contractor of any responsibility for proper integrated operations of all parts of the work, nor shall it act to relieve him of any responsibilities under Article A-6.04 of the Agreement, for guaranty of all parts of the work, for one year after the date of acceptance of all the work on the project.

SP-19 Prevention, Control and Abatement of Erosion and Water Pollution

The Contractor shall be responsible for prevention, control and abatement of erosion, siltation and water pollution resulting from construction of the project until final acceptance of the project.

He shall provide, install, construct, and maintain any covering, mulching, sodding, sand bagging, berms, slope drains, sedimentation structures, or other devices necessary to meet City, County, State and Federal regulatory agency codes, rules and laws.

The Contractor shall take sufficient precautions to prevent pollution of streams, canals, lakes, reservoirs and other water impoundments with fuels, oils, bitumen, calcium chloride or other

harmful materials. Also, he shall conduct and schedule his operations so as to avoid or otherwise minimize pollution or siltation of such streams, and the like, and to avoid interference with movement of migratory fish. No residue from dust collectors or washers shall be dumped into any live stream.

Storm drainage facilities, both open and closed conduit, serving the construction area shall be protected by the Contractor from pollutant and contaminants. If the Engineer determines that siltation of drainage facilities has resulted due to the project, the Engineer will advise the Contractor to remove and properly dispose of the deposited material. Should the Contractor fail to or elect not to remove the deposits, the City will provide maintenance cleaning as needed and will charge all costs of such service against the amount of money due or to become due the Contractor.

Construction operations in rivers, channels, streams, tidal waters, canals and other impoundments shall be restricted to those areas where it is necessary to perform filling or excavation to accomplish the work shown in the Plans and to those areas which must be entered to construct temporary or permanent structures. As soon as conditions permit, rivers, channels, streams and impoundments shall be promptly cleared of all obstructions placed therein or caused by construction operations.

Except as necessary for construction, excavated materials shall not be deposited in rivers, streams, canals or impoundments, or in a position close enough thereto to be washed away by high water or runoff.

The Contractor shall not disturb lands or waters outside the limits of construction except as may be found necessary and authorized by the Engineer.

The location of and methods of operation in all detention areas, borrow pits, material supply pits and disposal areas furnished by the Contractor shall meet the approval of the Engineer as being such that erosion during and after completion of the work will not likely result in detrimental siltation or water pollution.

The Contractor shall comply with the applicable provisions of the Hillsborough County Land Development Code concerning grading, filling, excavation, soil removal, and the like, as amended.

The Contractor shall schedule his operations such that the area of unprotected erodible earth exposed at any one time is not larger than the minimum area necessary for efficient construction operations; and the duration of exposed, uncompleted construction to the elements shall be as short as practicable.

Clearing and grubbing shall be so scheduled and performed that grading operations can follow immediately thereafter and grading operations shall be so scheduled and performed that permanent erosion control features can follow immediately thereafter if conditions on the project permit.

The Engineer may limit the surface areas of unprotected erodible earth exposed by clearing and grubbing, excavation or filling operations and may direct the Contractor to provide immediate

erosion or pollution control measures to prevent siltation or contamination of any river, stream, channel, tidal waters, reservoir, canal or other impoundment or to prevent damage to the project or property outside the project right of way.

SP-20 Project Sign

The Contractor shall furnish a project sign as shown on the detail included herein, and install it in the construction area as directed by the Engineer.

The cost of fabrication, erection, maintenance, removal, and proper disposal of the project sign at the completion of the project, including all labor and materials shall be deemed included in the prices bid for the various Contract Items of this Contract, or in the total Lump Sum Price, as applicable, and no separate payment will be made therefor.

No extra payment will be made for obliterating of certain names and offices and replacement thereof with others because of administrative changes during the course of the Contract.

SP-23 Project Cleanup

Cleanup is extremely important and the Contractor will be responsible for keeping the construction site neat and clean with debris to be removed regularly as the work progresses.

SP-26 Surface Restoration

Where construction activities are conducted in existing grassed areas, the grassed areas shall be restored as specified or directed by sodding or grassing. Such restoration of grassed areas shall conform to the requirements of the specifications.

The Contractor shall replace or repair all ground surfaces damaged during construction. Any bushes, flowers, gardens, patios, or other landscaping and irrigation systems disturbed by the construction project shall be repaired or replaced by the Contractor. The cost of such ground surface repair shall be included in the various classified unit price Contract Items, or in the total Lump Sum Price, as applicable, and no separate payment will be made therefor.

Existing corrugated metal and concrete pipe culverts removed during the construction work shall be stored and maintained in sound, useful condition and replaced upon completion of the work. Culverts damaged by the Contractor shall be replaced with new culverts meeting the applicable requirements of the Standard Specifications for Road and Bridge Construction published by the Florida Department of Transportation. No separate payment will be made for replacement of damaged culverts.

SP-33 Protection of Trees and Shrubs

All trees and shrubs, except where otherwise shown or ordered, shall be adequately protected by boxes, fences, or otherwise carefully supported, as necessary, by the Contractor.

Protective barricades shall be placed around all protected trees and grand trees and shall remain in place until all potentially damaging construction activities are completed (see attached barricade detail). The Parks Department must inspect the site after tree protection devices have been installed and prior to construction. A 48-hour notice must be given to Parks Department to schedule the inspection. No excavated or backfill material shall be placed in a manner which, in the opinion of the Engineer, may result in damage to trees or shrubs. Prior to mobilization, all exposed roots shall be covered with a two (2)-inch layer of mulch. The Contractor shall replace all trees or shrubs which are destroyed or damaged to such extent, in the opinion of the Engineer, to be considered destroyed. Replacement of destroyed trees or shrubs shall be made with new stock conforming to the requirements of the City's Tree Ordinance at the expense of the Contractor, and no separate payment will be made therefor.

Beneath trees within the limits of the excavation, and where possible, pipelines shall be built in short tunnels, except as otherwise shown or specified. When the tree is outside the limits of the excavation but, where the distance from the centerline of the new pipeline to the trunk of any tree is such that, in the opinion of the Engineer, the excavation would result in serious damage to the tree, the pipeline shall be constructed in short tunnel, as ordered in writing by the Engineer. The Contractor shall be responsible for all damage to trees and shrubs as a result of his operations, whether the pipeline is placed on trench, tunnel, or other excavation.

The Contractor shall provide the services of an approved licensed tree professional when it is necessary to trim or cut a branch from a tree.

The cost of protection of trees and shrubs, replacement or repair of trees or shrubs destroyed by the Contractor, short tunnels, and cutting or trimming of tree branches shall be included in the various classified unit price Contract Items for pipelines, or in the total Lump Sum Price, as applicable, and no separate payment will be made therefor.

SP-44 Standard for Filter Fabric

Unless specified otherwise on the Plans, filter fabric shall be nonwoven fabric per D.O.T. Specification Sections 514 and 985. Payment for furnishing and placing the filter fabric shall be included in the contract price for the item or items to which it is incidental.

SP-60 Contingency Allowance

The Contractor shall include a Ten Thousand Dollar (\$10,000) contingency allowance sum, to be included as part of the total bid amount for this contract for City use.

The Ten Thousand Dollar (\$10,000) contingency sum is an upset limit. Any amount of the contingency shall be paid only after negotiation.

SP-73 Work Directive Change

A Work Directive Change is a written directive to the Contractor, issued on or after the date of the execution of the Agreement, and signed by the Engineer on behalf of the City, ordering an addition, deletion or revision in the work, or responding to an emergency. A Work Directive

Change will not change the contract price or the time for completion, but is evidence that the parties expect that the change directed or documented by an Authorization to Proceed with Extra Work letter will be incorporated in a subsequently issued Change Order following negotiations by the parties as to its effect, if any, on the contract price or the time for completion.

Without invalidating the Agreement, additions, deletions or revisions in the work may, at any time or from time to time, be authorized by a Change Order or a Work Directive Change. Upon receipt of any such document, the Contractor shall promptly proceed with the work involved.

SP-85 Storage of Materials

The Contractor may not use that portion of the right-of-way located between the existing/proposed curb lines or existing/proposed edges of pavement to store pipe, structures, materials, surplus excavated fill, or equipment other than that used for excavating or dewatering. The Contractor may use that portion of the right-of-way behind the existing or proposed curb line or off the edge of pavement for storage provided that this use does not obstruct pedestrian or vehicular traffic and conforms to the City's Tree Ordinance. If the area behind the curb line/off the edge of pavement is insufficient in size to accommodate the Contractor's storage needs, the Contractor is required to secure the use of a vacant parcel of land for use as a storage site for the duration of this project. Upon completion of the project, all storage areas will be restored to a condition which meets or exceeds the pre-construction condition of the storage area. Payment for use and restoration of storage areas will be included in the appropriate lump sum pay items and unless the area is within the pipeline pay limits, no separate payment will be made therefor.

SP-88 Notice of Construction (Special Note for all FDOT Projects)

The Contractor shall provide a minimum of 48 hours notice to the Engineer prior to performing any work involving sanitary sewer facilities. In the event that the Contractor ceases operations for more than 3 consecutive working days, he shall again provide a minimum of 48 hours notice to the Engineer prior to performing any work involving sanitary sewer facilities.

SP-91 Project Photographs

The Contractor will not be required to furnish photographs of the project; however, the Engineer may or may not take photographs of the area immediately prior to and after completion of the construction for record and information. To assure that there will not be any conflict with this photography, the Contractor shall not perform clearing operations or action which will disturb any street or area within the project until the Engineer has been advised thereof and has had adequate opportunity to perform the desired photography.

SP-129 As-Built Plans

During manufacture and construction, installation and testing, records shall be kept of any changes or adjustments made in the work. All such changes shall be incorporated in the "As-Built" plans, shown in red.

The Contractor shall provide the City of Tampa with one (1) hardcopy and (1) electronic high resolution unsecured color PDF copy set of "As-Built" plans along with the supporting survey data and CAD files if available. The survey shall be signed and sealed by a licensed Land Surveyor registered with the Florida Department Board of Professional Surveyors and Mappers. Plan sheets shall have all deviations from original design annotated in red to clearly show as-built conditions. Relocation of existing facilities and utilities must be clearly noted and their location identified by station, offset and elevation, when performed by the Contractor.

As-builts shall clearly show installed horizontal and vertical location of all bends & fittings, valves, solid sleeves, hot tap sleeves & valves, lines stop tees permanently capped and left in active pipe, air release valve tap & valve boxes, tees, wyes, horizontal & vertical points of inflection, limits of removed pipes, limits of grouted pipes and limits of concrete encasements. Elevation deviations from the plans shall also be noted. If available, the Contractor shall provide the City with the Surveyor's electronic CAD file of the as-built locations.

Where applicable, As-builts shall conform to the "Record Drawing Requirements" section found in the City of Tampa Wastewater Department Technical Standards Guidelines for Construction of Wastewater Facilities (latest version). A copy of this standard can be found online on the City's Wastewater website.

All relocation of structures and pipelines must be clearly shown on Plans with as-built stations and offsets verified. All as-built inverts for the entire project must be clearly noted on plan sheets. No separate payment shall be made for this work.

All as-built plans shall be submitted within seven (7) calendar days of the final inspection. The final payment will not be issued until the as-built plans have been submitted to, and accepted by the City. Upon request by the Contractor, the City will provide AutoCAD drawings when available.



Page 1 of 2 –DMI Payment
City of Tampa – DMI Sub-(Contractors/Consultants/Suppliers) Payments
(FORM MBD-30)

[] Partial [] Final

Contract No.: _____ WO#,(if any): _____ Contract Name: _____

Contractor Name: _____ Address: _____

Federal ID: _____ Phone: _____ Fax: _____ Email: _____

GC Pay Period: _____ Payment Request/Invoice Number: _____ City Department: _____

Total Amount Requested for pay period: \$ _____ Total Contract Amount(including change orders):\$ _____

Type of Ownership - (F=Female M=Male), BF BM = African Am., HF HM = Hispanic Am., AF AM = Asian Am., NF NM = Native Am., CF CM = Caucasian S = SLBE

Type	Company Name Address Phone & Fax	Total Sub Contract Or PO Amount	Amount Paid To Date	Amount To Be Paid For This Period
Trade/Work Activity			Amount Pending Previously Reported	Sub Pay Period Ending Date
[]Sub []Supplier				
Federal ID				
			\$	\$
			\$	\$
			\$	\$
			\$	\$
			\$	\$
			\$	\$

(Modifying This Form or Failure to Complete and Sign May Result in Non-Compliance)

Certification: I hereby certify that the above information is a true and accurate account of payments to sub – contractors/consultants on this contract.

Signed: _____ Name/Title: _____ Date: _____



Page 2 of 2 – DMI Payment

Instructions for completing The DMI Sub-(Contractors/Consultants/ Suppliers) Payment Form (Form MBD-30)

This form must be submitted with all invoicing or payment requests where there has been subcontracting rendered for the pay period. If applicable, after payment has been made to the subcontractor, “Waiver and Release of Lien upon Progress Payment”, “Affidavit of Contractor in Connection with Final Payment”, or an affidavit of payment must be submitted with the amount paid for the pay period. The following will detail what data is required for this form. The instructions that follow correspond to the headings on the form required to be completed. **(Modifying or omitted information from this form my result in non-compliance).**

- **Contract No.** This is the number assigned by the City of Tampa for the bid or proposal.
- **W.O.#** If the report covers a work order number (W.O.#) for the contract, please indicate it in that space.
- **Contract Name.** This is the name of the contract assigned by the City of Tampa for the bid or proposal.
- **Contractor Name.** The name of your business.
- **Address.** The physical address of your business.
- **Federal ID.** A number assigned to a business for tax reporting purposes.
- **Phone.** Telephone number to contact business.
- **Fax.** Fax number for business.
- **Email.** Provide email address for electronic correspondence.
- **Pay Period.** Provide start and finish dates for pay period. (e.g. 05/01/13 – 05/31/13)
- **Payment Request/Invoice Number.** Provide sequence number for payment requests. (ex. Payment one, write 1 in space, payment three, write 3 in space provided.)
- **City Department.** The City of Tampa department to which the contract pertains.
- **Total Amount Requested for pay period.** Provide all dollars you are expecting to receive for the pay period.
- **Total Contract Amount (including change orders).** Provide expected total contract amount. This includes any change orders that may increase or decrease the original contract amount.
- **Signed/Name/Title/Date.** This is your certification that the information provided on the form is accurate.
- **See attached documents.** Check if you have provided any additional documentation relating to the payment data. Located at the bottom middle of the form.
- **Partial Payment.** Check if the payment period is a partial payment, not a final payment. Located at the top right of the form.
- **Final Payment.** Check if this period is the final payment period. Located at the top right of the form.

The following instructions are for information of any and all subcontractors used for the pay period.

- **(Type) of Ownership.** Indicate the Ethnicity and Gender of the owner of the subcontracting business or SLBE.
- **Trade/Work Activity.** Indicate the trade, service, or material provided by the subcontractor.
- **SubContractor/SubConsultant/Supplier.** Please indicate status of firm on this contract.
- **Federal ID.** A number assigned to a business for tax reporting purposes. This information is critical in proper identification of the subcontractor.
- **Company Name, Address, Phone & Fax.** Provide company information for verification of payments.
- **Total Subcontract Amount.** Provide total amount of subcontract for subcontractor including change orders.
- **Amount Paid To Date.** Indicate all dollars paid to date for the subcontractor.
- **Amount Pending, Previously Reported.** Indicate any amount previously reported that payments are pending.
- **Amount To Be Paid for this Period.** Provide dollar amount of dollars requested for the pay period.
- **Sub Pay Period Ending Date.** Provide date for which subcontractor invoiced performed work.

Forms must be signed and dated or will be considered incomplete. The company authorized representative must sign and certify the information is true and accurate. Failure to sign this document or return the document unsigned can be cause for determining a company is in non-compliance of Ordinance 2008-89.

If any additional information is required or you have any questions, you may call the Minority Business Development Office at (813) 274-5522.

Building a Better Tampa

Downtown Riverwalk

Creates a waterfront pedestrian walkway connecting the south edge of the CapTrust building with MacDill Park.

\$1.5 Million investment
Scheduled for completion in October, 2012

Orion Marine
Construction, Inc.

Improvement Project



Mayor Bob Buckhorn

Project Contact:
Don Cermeno
Contract Administration
City of Tampa
Don.Cermeno@tampagov.net

For information call:
(813) 635-3400



SIGN EXAMPLE ONLY GRAPHIC TO BE DEVELOPED BY CONTRACTOR

scale: 3"

Sign Information

Building a Better Tampa

**David L. Tippin Water Treatment Facility
Caustic Soda Piping Improvements**

Project provides for improvements at the David L. Tippin Water Treatment Facility to improve the reliability and safety of the Sodium Hydroxide System of the water distribution system within the facility.

\$TBD investment
Scheduled for completion in TBD 2014

TBD

Colors

Blue: Sherwin Williams Naval SW6244
Green: Sherwin Williams Center Stage SW6920
White: Sherwin Williams Pure White SW7005

Font

Franklin Gothic

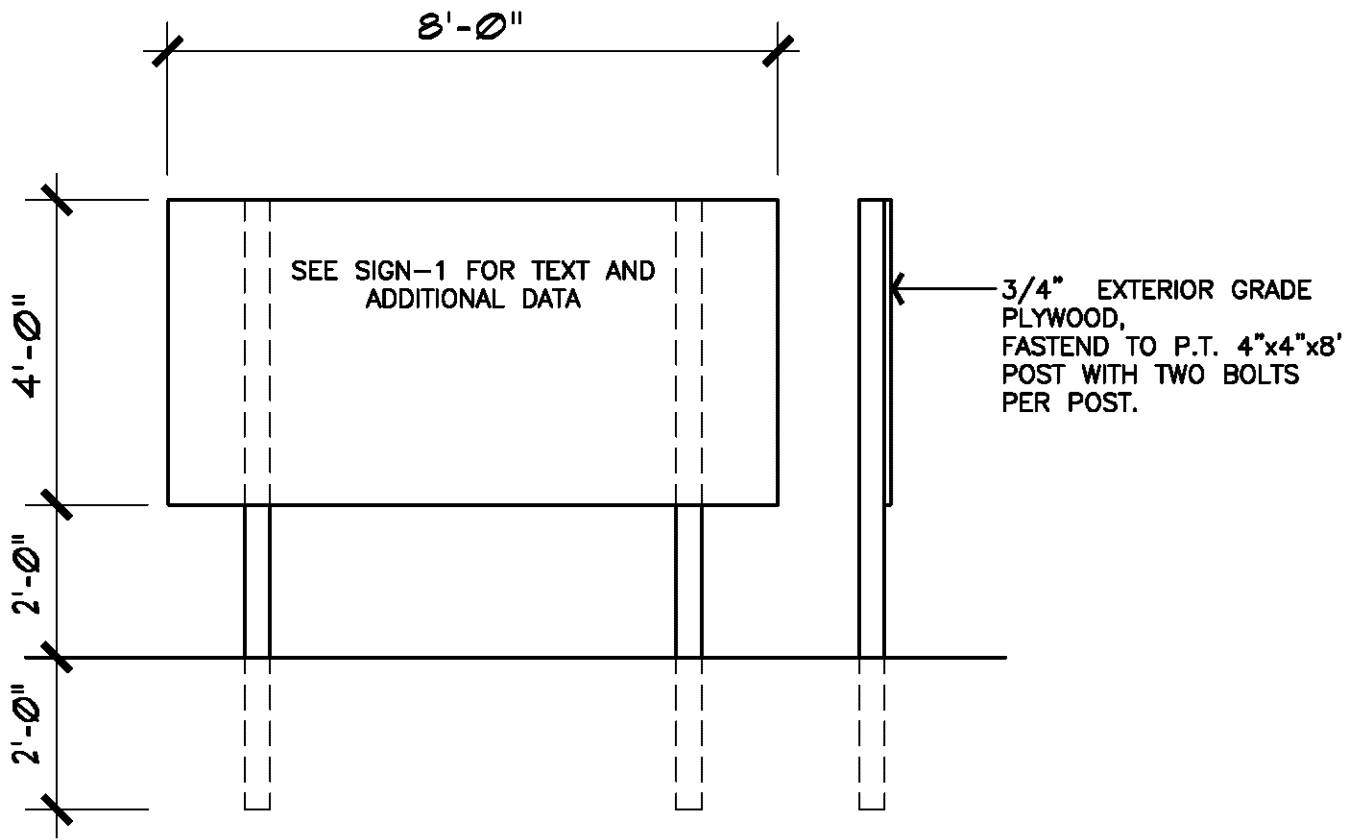

SECTION 01010 - SUMMARY OF WORK

1.0 GENERAL:

The work shall consist of furnishing all materials, labor, equipment, tools, and all items and services required for the complete construction in conformity with Contract Documents of:

Lois Pumping Station Driveway
at
: 4207 W. Oklahoma Ave. Tampa, FL 33616
for the
City of Tampa

All construction work and materials, in addition to complying with requirements of Contract Documents, shall fully comply with all requirements of local building codes, all ordinances, and regulations of other Federal, State and public authorities having jurisdiction over this type of work in the given area.

2.0 SCOPE:

The work shall include but not be limited to, furnishing all labor, materials and equipment to add an asphalt access driveway and retention pond as specified in construction plans, with all associated work required for a complete project, as shown and indicated on the Drawings and in the Specifications.

3.0 LEGAL DESCRIPTION OF PROJECT SITE:

Legal description as shown on the drawings, Sheet G-1.

4.0 VERIFICATION OF OWNER'S SURVEY DATA:

Prior to commencing any work, the Contractor shall satisfy himself as to accuracy of all survey data which shall affect his work as indicated in these plans and specifications and/or provided by the City.

Should the Contractor discover any inaccuracies or errors which will affect his work, he shall notify the Engineer and/or Architect in order that proper adjustments can be ordered.

The exact location of the building and related items shall be determined on site jointly by the Contractor and the Engineer and/or Architect. NO work shall commence until said final approval of the locations is made by the Engineer and/or Architect.

5.0 CONTRACT DOCUMENTS:

- a. BIDDING REQUIREMENTS
- b. GENERAL PROVISIONS, SUPPLEMENTARY GENERAL PROVISIONS, AND SPECIAL CONDITIONS

6.0 SPECIFICATIONS: (DATED: February, 2017)

Divisions: 1, 3, Supplementary General Provisions, Special Conditions and Specific Provisions

7.0 DRAWINGS: (DATED: December , 2016)

Sheets: CX.0, C0.0, C0.1, C1.0, C1.1, C2.0, C2.1, C3.0 and C3.1

8.0 ADDENDA AND LETTERS OF CLARIFICATION:

All addenda and letters of clarification issued prior to bid opening time date.

SECTION 033000

CAST-IN-PLACE CONCRETE

PART 1 - GENERAL

1.01 SCOPE

- A. This Section supplements the project drawings and specifies project technical requirements, and defines workmanship, quality control procedures, and identifies governing codes and standards for placement, consolidation, finishing, curing, testing and final acceptance of cast-in-place concrete for the structural components of this Project. Equipment bases and mechanical pads shown on architectural, structural, civil, mechanical, plumbing or electrical drawings are included under this Section. Note that mechanical pads are not typically shown on structural drawings.

1.02 RELATED DOCUMENTS

- A. The general provisions of the contract, including General Conditions, Supplementary Conditions and General Requirements apply to the work specified in this Section.

1.03 RELATED WORK SPECIFIED ELSEWHERE

- A. Section 033010 - Concrete - General
- B. Section 033020 - Concrete Formwork
- C. Section 033030 - Concrete Reinforcement

1.04 QUALITY ASSURANCE

- A. Codes and Standards: Comply with provisions of the latest edition of the following codes, specifications and standards, except where more stringent requirements are shown or specified:
 - 1. ACI 301-99 "Specifications for Structural Concrete for Buildings."
 - 2. ACI 304R-89 "Guide for Measuring, Mixing, Transporting and Placing Concrete."
 - 3. ACI 305R-91 "Hot Weather Concreting."
 - 4. ACI 309R-96 "Guide for Consolidation of Concrete."
 - 5. ACI 311.4R-95 "Guide for Concrete Inspection."
 - 6. ACI 318-02 "Building Code Requirements for Reinforced Concrete."
 - 7. Florida Building Code 5th Edition 2014
 - 8. CRSI "Recommended Practice for Placing Reinforcing Bars"
 - 9. American Society of Testing and Materials (ASTM)
- B. Concrete Testing Service: Refer to Section 033010, Concrete-General.
- C. Field Reference Manual: Have available at the project field office a copy of ACI SP-15(95) "Standard Specifications for Structural Concrete ACI 301 with Selected ACI and ASTM References."

1.05 DEFINITION

- A. See Section 033010 for definition concrete exposure.

1.06 SUBMITTALS

- A. Coordinate the work of this Section with requirements for submittals specified in Section 033010.
- B. Operations Manual: Sufficiently in advance of concrete placement to allow through review, submit to the Architect and Engineer the following information, bound in the form of a manual:

1. Design mixes and test results for each classification of concrete, including brand names of cement and admixtures, and source and type of aggregates. Refer to Section 033010, Concrete, General.
 2. Description of proposed waterstops, with name of manufacturer, including specifications and instructions for surface preparation, installation and splicing.
 3. Description of reinforcing bar support, with name of manufacturer.
 4. Drawing showing construction joint locations and pour sequence and elapsed time between pours for each classification of concrete.
 5. For each pour sequence, the method of placement.
 6. For each pour sequence, the method of curing the concrete. For wet cures, indicate the method. For curing compounds, submit manufacturer's instructions for application.
 7. Location of cleanouts for wall and column forms, and the method of closing the cleanouts.
 8. Description of shoring and reshoring procedure.
 9. Type of formwork for each pour.
 10. Type of chamfer strips, rustication strips and control joint inserts, if any, for slabs-on-ground.
 11. Type of wall ties, indicating break-off points and cones.
 12. Method of achieving special finishes as called for.
 13. Type and brand name of sealants used.
 14. Description and manufacturer's instructions for application of epoxy-based patching compounds.
 15. Type of non-shrink grout and manufacturer's instructions for application.
- C. Maintain a copy of the "Approved" Operations Manual in the field office at all times.
- D. No deviations will be allowed from products and procedures outlined in the "Approved" Operations Manual, except when permission is requested in writing and approval for same has been given by the Architect and Engineer.

1.07 PRE-CONSTRUCTION CONFERENCE

- A. The Contractor is responsible for scheduling a Pre-Construction Conference prior to the start of concrete construction.
- B. The purpose of the conference is to highlight and discuss concrete aspects contained in this Section and Section 033010 of the Specifications the thorough understanding of which is essential to the success of the Project.
- C. The Agenda for the Pre-Construction Conference will be prepared by the Structural Engineer of Record. All participants will be free to add items for discussion at any time before and during the Conference.
- D. The following participants will attend the Pre-Construction Conference:
 1. Owner's representative
 2. Testing and Inspection Agency representative
 3. Concrete Contractor's representative
 4. Structural Engineer of Record
- E. Refer to Specification Section 033010 for additional details.
- F. This Pre-Construction Conference may be combined with the conference stipulated in Specification Section 033010.

PART 2 - PRODUCTS

2.01 CONCRETE

- A. For concrete materials, refer to Section 033010.

2.02 JOINT MATERIALS

- A. Waterstops:
 - 1. Furnish one of the following waterstops:
 - a. Synko-Flex by Synko-Flex Products, Inc., Houston, TX
 - b. Waterstop RX by American Colloid Co., Arlington Hts., IL
 - c. Swellseal Type CC by De Neef America, Inc., St. Louis, MO
 - 2. Follow manufacturer's requirements for surface preparation, priming, butt-splicing. Submit sample, 12 inches [30 cm] long.

2.03 MOISTURE BARRIER

- A. Provide moisture barrier cover over prepared base material where shown on the project drawings. Note that aquatic concrete pool base slabs do not require moisture barrier. Use only materials which are resistant to decay when tested in accordance with ASTM E 154.
- B. Use polyethylene sheets not less than 6 mils [0,2 mm].

2.04 VAPOR BARRIER

- A. Vapor Barrier: Premolded membrane conforming to ASTM E 96, Method B, O vapor transmission rate.
- B. Provide vapor barrier over prepared base material where shown on the project drawings. Note that aquatic concrete pool base slabs do not require vapor barrier. Use only materials which are resistant to decay.

2.05 BONDING AND PATCHING MATERIALS

- A. Refer to Section 033010 for bonding and patching materials.

2.06 CONCRETE CURING MATERIALS

- A. Moisture-Retaining Cover: One of the following, complying with ASTM C 171.
 - 1. Waterproof paper.
 - 2. Polyethylene film.
 - 3. White burlap-polyethylene sheet.
- B. Liquid Membrane-Forming Curing Compound, complying with ASTM C 309, Type I (clear), Class A & B, or Type II (white pigmented), Class A & B:
 - 1. Use a compound which conforms to Federal Specification TT-C-800A, 30% solids content minimum, and have test data from an independent laboratory indicating a maximum moisture loss of 0.030 grams per sq. cm. when applied at a coverage rate of 300 sq.ft. per gallon [7,5 m²/liter]. Manufacturer's certification is required. Provide liquid membrane-forming compound as manufactured by one of the following:
 - a. Super Floor Coat or Super Pliocure by Euclid Chemical Co.
 - b. Cure-N-Seal HS by Master Builders
 - c. Sealco 30% by W. R. Grace Co.
- C. See Part 3. for curing requirements for aquatic concrete.

2.07 CRYSTALLINE WATERPROOFING SYSTEM

- A. Provide where noted on the drawings.
- B. Cementitious crystalline penetrating waterproofing:
 - 1. AQUAFING-IC Slurry by Aquafin, Inc.
- C. Fast setting waterproof repair and sealing mortar:
 - 1. AQUAFIN MORTAR-IC by Aquafin, Inc.
- D. Fast setting crystalline cementitious waterstop and patching mortar:

1. AQUAFIN-PLUG-IC by Aquafin, Inc.

2.08 CONCRETE SEALER

- A. Provide concrete sealer where scheduled, as manufactured by one of the following:
 1. Euclid Chemical Co.
 2. Master Builders
- B. The manufacturer is to recommend the product best suited for the applied finishes and anticipated use of the surface.
- C. The concrete sealer is to be applied twice. The first application is to be as soon as possible. The second application is to be colored and applied just prior to the building being turned-over to the Owner.

2.09 NON-SHRINK GROUT

- A. For non-shrink grout materials, refer to Section 033010.
- B. Provide for all beam seats bearing on concrete, all equipment bases, and other locations noted on the project drawings. Provide non-metallic type only for exposed conditions or where contact with water is anticipated.
- C. Conform to CRD-C-621-80, "Corps of Engineers Specifications for Non-Shrink Grout.

PART 3 - EXECUTION

3.01 PREPARATION

- A. Before formwork installation and prior to placing concrete, thoroughly inspect and verify that all reinforcing tie wires are bent away from formed surfaces to the specified minimum clearance.
- B. Before placing concrete, inspect and complete the formwork installation, reinforcing steel and items to be embedded or cast-in. Notify other crafts in ample time to permit the installation of their work; cooperate with other trades in setting such work, as required.
- C. Before placing concrete:
 1. Arrange for an on-site review by the Structural Engineer of Record of the in-place construction prior to concrete placement. This on-site review should be timed so that at least 90 percent of the reinforcing, waterstops and embedded items are in place and that the items in place are easily observable. Provide observation ports in the formwork as required for the review. Allow sufficient time for adjustments and changes to reinforcing and other installed items as may be required by the Engineer of record prior to placing concrete.
 2. Inspect construction joints in walls containing waterstops through the inspection and clean-out ports in the formwork
 3. Clean surface of construction joint of all debris, including dust, sawdust, form oil, and all other foreign objects which will impair bond and water tightness in the joint
 4. Inspect, and correct if necessary, the placement, splicing and joining of waterstop
 5. Clean surface of waterstop of all debris and waterstop protective tape
 6. Apply specified bonding agent
 7. Replace, close, support and seal observation and clean-out port closure panel
- D. Do not place concrete until completing all items listed in the sub-paragraph above.
- E. Thoroughly wet wood forms immediately before placing concrete, as required where form coatings are not used.
- F. Where reinforcing bars are exposed to solar radiation, assure that the temperature of the reinforcing bars is less than 140 degrees F. If the reinforcing bars are too hot to touch by the bare hand, cool reinforcing bars with water spray. If water spray is used, do not allow pools of water to collect which might be incorporated into the concrete to be placed, as this will increase the water-

cementitious materials ratio. Covering by water-soaked burlap to lower the steel temperature is permissible.

- G. Coordinate the installation of joint materials and moisture barriers with placement of forms and reinforcing steel.
- H. Before concrete placement, inspect and verify that grades of all earth surfaces used as concrete forms are correct and that the proper specified clearance is maintained to reinforcing bars.

3.02 CONCRETE CONVEYING

- A. Handle concrete from the point of delivery and transfer to the concrete conveying equipment and to the locations of final deposit as rapidly as practicable by methods which will prevent segregation and loss of concrete mix materials.
- B. Use mechanical equipment for conveying concrete to ensure a continuous flow of concrete at the delivery end. Erect runways for wheeled concrete conveying equipment from the concrete delivery point to the locations of final deposit. Keep interior surfaces of conveying equipment, including chutes, free of hardened concrete, debris, water and other deleterious materials.

3.03 PLACEMENT AND CONSOLIDATION OF CONCRETE

- A. Place concrete in compliance with the practice and recommendations of ACI 304, and as herein specified.
- B. Do not use concrete which becomes non-plastic and unworkable, or does not meet the required quality control limits, or which has been contaminated by foreign materials. Do not use re-tempered concrete. Remove rejected concrete from the project site and dispose of in an acceptable location.
- C. Deposit concrete continuously or in layers of such thickness that no concrete will be placed on concrete which has hardened sufficiently to cause the formation of seams or planes of weakness within the section.
- D. Deposit concrete into forms in horizontal layers not deeper than 24 inches and in a manner to avoid inclined construction joints. Where placement consists of several layers, place each layer while preceding layer is still plastic to avoid cold joints.
- E. Do not use consolidation equipment (vibrator) to spread concrete.
- F. If a section cannot be placed continuously, provide construction joints as herein specified. Deposit concrete as nearly as practicable to its final location to avoid segregation due to re-handling or flowing. Do not subject concrete to any procedure which will cause segregation.
- G. Screed concrete which is to receive other construction to the proper level to avoid excessive skimming or grouting.
- H. Remove temporary spreaders in forms when concrete placing has reached the elevation of such spreaders.
- I. Consolidate concrete placed into forms by mechanical vibrating equipment supplemented by hand-spading, rodding, or tamping. Use equipment and procedures for consolidation of concrete in accordance with the recommended practices of ACI 309, to suit the type of concrete and project conditions. Vibration of forms and reinforcing will not be permitted, unless otherwise accepted by the Owner.
- J. Do not use vibrators to transport concrete inside the forms. Insert and withdraw vibrators vertically at uniformly spaced locations not farther than the visible effectiveness of the machine. Place vibrators to rapidly penetrate the layer of concrete and at least 6 inches into preceding layer. Do not insert vibrators into lower layers of concrete that have begun to set. At each insertion,

limit the duration of vibration to the time necessary to consolidate the concrete and complete embedment of reinforcement and other embedded items without causing segregation of the mix.

- K. Do not place concrete in supporting elements until the concrete previously placed in columns and walls is no longer plastic.
- L. Deposit and consolidate concrete slabs in a continuous operation, within the limits of construction joints, until the placing of a panel or section is completed.
- M. Consolidate concrete during placing operations using mechanical vibrating equipment, so that concrete is thoroughly worked around reinforcement and other embedded items and into corners. Where concrete cover in excess of 2 inches is called for in walls and columns, consolidate concrete by inserting the mechanical vibrator between the reinforcing curtain and the face of the formwork.
- N. Consolidate concrete placed in beams and girders of supported slabs, and against bulkheads of slabs on ground, as specified for formed concrete structures. Consolidate concrete in the remainder of slabs by vibrating bridge screeds, roller pipe screeds, or other acceptable methods. Limit the time of vibrating consolidation to prevent bringing an excess of fine aggregate to the surface.
- O. Bring slab surfaces to the correct level with a straightedge and strike off. Use bull floats or darbies to smooth the surface, leaving it free of high or low areas. Do not sprinkle water or cement on the plastic surface. Do not disturb the slab prior to beginning the finishing operations.
- P. Maintain reinforcing steel, tie wires and forms in the proper position continuously during concrete placement operations.

3.04 BONDING

- A. Roughen surfaces of set concrete at all joints by sandblasting or wire brushing using power tools, except where bonding is obtained by use of concrete bonding agent, and clean surfaces of laitance, coatings, loose particles and other foreign matter. Roughen surfaces in a manner to expose bonded aggregate uniformly and to not leave laitance, loose particles of aggregate or damaged concrete at the surface.
- B. Prepare for bonding of fresh concrete to new concrete that has set but is not fully cured, as follows:
 - 1. At joints between footings and walls or columns and between walls or columns and beams or slabs they support, and elsewhere unless otherwise specified herein, dampen but do not saturate, the roughened and cleaned surface of set concrete immediately before placing fresh concrete.
 - 2. At joints in exposed work, at vertical joints in walls, at joints in girders, beams, supported slabs and other structural members and at joints designed to contain liquids; apply to the roughened and cleaned surface of set concrete either a commercial bonding agent or neat cement grout.
 - 3. Apply commercial bonding agent in accordance with printed instructions of the manufacturer.
 - 4. Apply neat cement grout, consisting of equal parts by weight of portland cement and aggregate mixed with water to the consistency of thick cream, to dampen concrete surfaces with a stiff broom or brush to a minimum thickness of 1/16 inch. Deposit fresh concrete before grout has attained its initial set.

3.05 HOT WEATHER PLACING

- A. When hot weather conditions exist (80E F. [26E C] and higher), place concrete in compliance with ACI 305 and as herein specified.
- B. Cool ingredients before mixing to maintain concrete temperature at time of placement that will not cause difficulty from loss of slump, flash sets or cold joints, but not greater than 90E F. [32E C].

Mixing water with chilled or chopped ice may be used to control the concrete temperature, provided the water equivalent of the ice is calculated as part of the total amount of mixing water.

- C. Cover reinforcing steel with water-soaked burlap if it becomes too hot, so that steel temperature will not exceed the ambient air temperature immediately before embedment in concrete.
- D. Wet wood forms thoroughly before placing concrete.
- E. Use set-control admixtures when required and accepted in mix designs.

3.06 CONSTRUCTION JOINTS

- A. Locate and install construction joints, which are not shown on the project drawings, so as not to impair strength and appearance of the structure, as acceptable to the Architect and Engineer. Locate construction joints, if required but not shown, as follows:
 - 1. In walls, columns or piers, at the top of footings; at the top of slabs on ground; and at the underside of the deepest beam or girder framing into the column or pier.
 - 2. In framed slabs and beams, obtain the Engineer's approval for locating between the 1/4 and the 1/3 point of the span.
 - 3. In slabs on ground, at approximately 45-foot [14 m] spacing, so as to divide the slab into square or nearly square areas not in excess of 2000 sq. ft. [180 m²], unless otherwise shown on the project drawings or accepted by the Engineer.
 - 4. In walls, at approximately 60-foot [18 m] spacing.
- B. Provide formed keyways at least 1 1/2 inch [4 cm] deep in construction joints in walls, slabs, and between footings.
- C. Place construction joints perpendicular to the main reinforcement. Continue reinforcement across construction joint.
- D. Install waterstops in construction joints as shown on the project drawings. Install waterstops to form a continuous diaphragm in each joint. Make provisions to support and protect waterstops during the progress of work. Fabricate field joints in waterstops in accordance with manufacturer's printed instructions. Protect waterstop material from damage where it protrudes from any joint.

3.07 CONTROL JOINTS

- A. Walls:
 - 1. Install control joints in concrete retaining walls at the spacing shown on the project drawings or at 20'-0" [6.0 m] intervals.
 - 2. Refer to the project drawings for concrete and reinforcing detail at control joints.
- B. Control joints are not allowed in aquatic concrete water-containing elements.

3.08 FINISH OF FORMED SURFACES

- A. Rough Form Finish: Apply as-cast rough form finish to formed concrete surfaces that are to be concealed in the finish work or by other construction, unless otherwise indicated. Standard rough form finish is defined as the concrete surface having the texture imparted by the form facing material used, with tie holes and defective areas repaired and patched and all fins and other projections exceeding 1/4 inch [6 mm] in height rubbed down or chipped off.
- B. Smooth Form Finish: Apply as-cast smooth form finish for formed concrete structures that are to be exposed-to-view, or that are to be covered with a coating material applied directly to the concrete, or a covering material bonded to the concrete such as waterproofing, damp-proofing, painting or other similar system.

1. Produce smooth form finish by selecting form materials to impart a smooth, hard, uniform texture and orderly and symmetrically arranging them with a minimum of seams. Repair and patch defective areas with all fins or other projections completely removed and smoothed.
- C. Related Unformed surfaces: At tops of walls, tops of railings, horizontal offsets, and other similar unformed surfaces occurring adjacent to formed surfaces, strike off smooth with trowel and finish with texture matching the adjacent formed surfaces. Continue the final surface treatment of formed surfaces. Continue the final surface treatment of formed surfaces uniformly across the adjacent unformed surfaces, unless otherwise shown. Carry vertical rustication joints around the tops of walls, railings and horizontal offsets.
- D. Smooth Rubbed Finish:
1. Provide smooth rubbed finish to scheduled concrete surfaces, which have received smooth form finish treatment, not later than the day after form removal.
 2. Moisten concrete surfaces and rub with a carborundum brick or other abrasive until a uniform color and texture is produced.
 3. Do not apply cement grout other than that created by the rubbing process.

3.09 MONOLITHIC SLAB FINISHES

- A. Float Finish (Flt-Fn): Apply float finish to monolithic slab surfaces that are to receive trowel finish and other finishes as hereinafter specified, and slab surfaces which are to be covered with membrane or elastic waterproofing, membrane or elastic roofing or sand bed terrazzo, and as otherwise shown on project drawings or in schedules.
1. After placing concrete slabs, do not work the surface further until ready for floating. Begin floating when the surface water has disappeared or when the concrete has stiffened sufficiently to permit the operation of a power-driven float, or both. Consolidate the surface with power-driven floats, or by hand-floating if area is small or inaccessible to power units.
 2. Cut down high spots and fill low spots. Uniformly slope surfaces to drains. Immediately after leveling, refloat the surface to a uniform, smooth, granular texture.
- B. Trowel Finish: Apply trowel finish to monolithic slab surfaces that are to be exposed to view, unless otherwise shown.
1. After floating, begin the first trowel finish operation using a power-driven trowel. Begin final trowelling when the surface produces a ringing sound as the trowel is moved over the surface.
 2. Consolidate the concrete surface by the final hand trowelling operation free of trowel marks, uniform in texture and appearance and with surface plane tolerance not exceeding 3/16 inch [5 mm] in 10' [3 m] when tested with a 10' [3 m] straightedge. Grind smooth surface defects
- C. Non-Slip Broom Finish (NsBrm-Fn): Apply non-slip broom finish to top of exposed slabs, platforms, steps, ramps, and also where shown on the project drawings or in schedules.
1. Immediately after trowel finishing, slightly roughen the concrete surface by brooming in the direction perpendicular to the main traffic route or in the pattern shown on the project drawings. Use fiber-bristle broom unless otherwise directed.
 2. Coordinate the required final finish with the Owner before application.

3.10 CONCRETE CURING AND PROTECTION

- A. General: Protect freshly placed concrete from premature drying and excessive cold or hot temperature and maintain without drying at a relatively constant temperature for the period of time necessary for hydration of the cement and proper hardening of the concrete.
- B. Start initial curing as soon as free moisture has disappeared from the concrete surface after placing and finishing. Weather permitting, keep continuously moist for not less than seventy-two hours.

- C. Begin curing procedures immediately following initial curing and before the concrete has dried. Continue final curing for at least 10 days and in accordance with ACI 301 procedures. Avoid rapid drying at the end of the final curing period.
- D. Curing Methods: Perform curing of concrete by moisture curing, by moisture retaining cover curing, membrane curing, or by combinations thereof, as herein specified. For curing, use only water that is free of impurities which could etch or discolor exposed, natural concrete surfaces. Membrane curing is not permitted for aquatic concrete elements, only moisture curing is acceptable.
 - 1. Apply moisture curing by any one of the following methods:
 - a. Keeping the surface of the concrete continuously wet by covering with water.
 - b. Continuous water-fog spray.
 - c. Covering the concrete surface with the specified absorptive cover, thoroughly saturating the cover with water, and keeping the absorptive cover continuously wet. Place absorptive cover so as to provide coverage of the concrete surfaces and edges, with a 4-inch [10 cm] lap over adjacent absorptive covers.
 - 2. moisture-cover curing as follows: Cover the concrete surfaces with the specified moisture retaining cover for curing concrete, placed in the widest practicable width with sides and ends lapped at least 4 inches [10 cm] and sealed by waterproofing tape or adhesive. Immediately repair any holes or tears during the curing period using cover material and waterproof tape.
 - 3. Apply liquid membrane curing as follows:
 - a. Apply specified membrane-forming curing compound to damp concrete surfaces as soon as possible after final finishing operations are complete, but no later than 2 hours. Apply uniformly in a continuous operation by power spray equipment or roller equipment in accordance with the manufacturer's directions. Recoat areas which are subjected to heavy rainfall within 3 hours of initial application. Maintain the continuity of the coating and repair damage to the coat during the entire curing period.
 - b. Do not use membrane curing compounds on exterior, exposed, or aquatic concrete surfaces or on surfaces which are to be covered with a coating material applied directly to the concrete or with a covering material bonded to the concrete, such as other concrete.
- E. Curing Formed Surfaces: Cure formed surfaces, including the undersides of girders, beams, supported slabs, and other similar surfaces by moist curing with the forms in place for the full curing period or until forms are removed. If forms are removed, continue curing by methods specified above, as applicable.
- F. Curing Unformed Surfaces: Initially cure unformed, such as slabs, floor topping, and other flat surfaces by moist curing, whenever possible.
 - 1. Final cure unformed surfaces, unless otherwise indicated, by any one of the methods specified above, as applicable.
 - 2. Final cure concrete surfaces to receive finish flooring by use of moisture-retaining cover, unless otherwise acceptable to the Owner.
- G. Temperature of Concrete During Curing:
 - 1. When the atmospheric temperature is 40E F. [4E C] and below, maintain the concrete temperature between 50E and 70E F. [10E and 20E C] continuously throughout the curing period. When necessary, make arrangements before concrete placing for heating, covering, insulation, or housing as required to maintain the specified temperature and moisture conditions continuously for the concrete curing period.
 - 2. When the atmospheric temperature is 80E F. [25E C] and above, during other climatic conditions which will cause too rapid drying of the concrete, make arrangements before the start of concrete placing for the installation of windbreaks or shading, and for fog spraying, wet sprinkling or moisture-retaining covering. Protect the concrete continuously for the

- concrete curing periods. Provide hot weather protection complying with the requirements of ACI 305.
3. Maintain concrete temperature as uniformly as possible, and protect from rapid atmospheric changes. Avoid temperature changes in concrete which exceed 5E F. [3E C] in any one hour and 50E F. [30E C] in any 24 hour period.
- H. Protection from Mechanical Injury: During the curing period, protect concrete from damaging mechanical disturbances including loading stresses, vibration from heavy rock excavation, and from damage caused by rain or flowing water. Protect finished concrete surfaces from damage by subsequent construction operation.

3.11 MISCELLANEOUS CONCRETE ITEMS

- A. Filling-In: Fill in holes or openings left in concrete members by the passage of work or by other trades, unless otherwise shown or directed, after the work of other trades is in place. Mix, place, and cure epoxy-based patching compound as herein specified, to blend with in-place construction. Provide all other miscellaneous concrete filling shown or required to complete the work.
- B. Tie Holes in Aquatic Concrete: Fill in form tie holes to a minimum depth of 2". Mix, place, and cure epoxy-based patching compound or crystalline cementitious waterstop and patching mortar as herein specified, to blend with in-place construction. Air pockets in the filling are not allowed.
- C. Tie Holes in Non-Aquatic Concrete: fill with dry pack mortar, or one of the specified epoxy based bonding and patching compounds, or use precast cement cone plugs secured in place with bonding agent.
- D. Non-Aquatic Concrete Curbs: Apply monolithic finish to interior curbs by stripping forms while concrete is still green and steel trowelling surfaces to a hard dense finish with corners, intersections, and terminations slightly rounded. Extend rustication strips over the top of the curbs forming one continuous line with the vertical rustication strip.
- E. Equipment Bases and Foundations: Install equipment bases and foundations, as shown on architectural, structural, civil, mechanical, plumbing and electrical drawings. Note that such bases and foundations are not typically shown on the structural drawings. Set anchor bolts for machines and equipment to template at correct elevations, complying with certified diagrams or templates of the manufacturer furnishing the machines and equipment.

3.12 CONCRETE SURFACE REPAIRS

- A. Patching Defective Areas: Repair and patch defective areas with epoxy-based patching compound immediately after removal of forms, but only when directed by the Owner.
- B. Cut out honeycomb, rock pockets, voids over 1/2 inch [1 cm] in any dimension down to solid concrete, but in no case to a depth of less than 1 inch [3 cm]. Make edges of cuts perpendicular to the concrete surface. Before placing epoxy-based patching compound, thoroughly clean surfaces to be repaired as required by manufacturer's specifications. Compact in place and strike off slightly higher than the surrounding surface.
- C. Repair of Formed Surfaces: Repair exposed-to-view formed concrete surfaces, where possible, that contain defects which adversely affect the appearance of the finish. Remove and replace the concrete having defective surfaces if the defects cannot be repaired to the satisfaction of the Architect. Surface defects, as such, include color and texture irregularities, cracks, spalls, air bubbles larger than 1/4 inch [6 mm], honeycomb, rock pockets, fins, and other projections on the surface; and stains and other discolorations that cannot be removed by cleaning.
 1. Flush out form tie holes in non-aquatic concrete, fill with dry pack mortar or precast cement cone plugs secured in place with bonding agent.
 2. Repair concealed formed concrete surfaces, where possible, that contain defects that adversely affect the durability of the concrete. If defects cannot be repaired, remove and replace the concrete having defective surfaces. Surface defects, as such, include cracks of

- any width and other surface deficiencies which penetrate to the reinforcement or completely through non-reinforced sections, honeycomb, rock pockets, and spalls, except minor breakage at corners.
- D. Repair of Unformed Surfaces: Test unformed surfaces, such as monolithic slabs, for smoothness and to verify surface plane to the tolerances specified for each surface and finish. Correct high areas as herein specified.
1. Test unformed surfaces sloped to drain for trueness of slope, in addition to smoothness, using a template having the required slope.
 2. Correct high and low areas as herein specified.
 3. Repair finished unformed surfaces that contain defects which adversely affect the durability of the concrete. Surface defects, as such, including crazing, cracks in excess of 0.01 inch [0,25 mm] wide or which penetrate to the reinforcement or completely through non-reinforced sections regardless of width, spalling, popouts, honeycomb, rock pockets, and other objectionable conditions.
- E. High and Low Areas: Test floor areas for high and low spots. A maximum variation of 1/4 inch [6 mm] in 10' [3 m] is permitted, with a 3/4 inch [2 cm] maximum in 45' [13,5 m], as determined by a 10' straightedge placed anywhere on the floor slab, or as directed by the Owner, Architect or Engineer.
1. high areas in unformed surfaces by grinding, after the concrete has cured sufficiently so that repairs can be made without damage to adjacent areas.
 2. Correct low areas in unformed surfaces during, or immediately after completion of surface finishing operations by cutting out the low areas and replacing with fresh concrete. Proprietary compounds may be used when acceptable to the Owner.
- F. Repair defective areas, except random cracks and single holes not exceeding 1 inch in diameter, by cutting out and replacing with epoxy-based patching compound. Architect and Engineer may direct that defects in certain concrete areas not in contact with salt water to be repaired through replacement with fresh concrete. Remove defective areas to sound concrete with clean, square cuts and expose reinforcing steel with at least 3/4 inch clearance all around. Follow manufacturer's instructions for application of epoxy-based patching compound. Where Owner, Architect or Engineer permits patching with fresh concrete, dampen concrete surfaces in contact with patching concrete and brush with a neat cement grout coating, or use concrete bonding agent. Place patching concrete before concrete takes its initial test. Mix patching concrete of the same materials to provide concrete of the same type or class as the original adjacent concrete. Cure in the same manner as adjacent concrete.
- G. Repair cracks, holes, and other defects in pools, tanks and pits by the epoxy-injection method as directed by the Owner, Architect and Engineer.

3.13 CLEAN DOWN AND WATER REPELLENT

- A. Clean all concrete surfaces, interior and exterior, with a mild solution of detergent and water. Apply the solution by scrubbing vigorously with a soft bristle brush, and then flush with water.
- B. Coat all non-aquatic concrete surfaces exposed to weather with a clear acrylic sealer in accordance with manufacturer's printed directions. Use the following, or equivalent:
1. Thoroglaze (2 coats) by Standard Dry Wall Products
 2. Rez-Seal by Euclid Chemical Co.
 3. Rheomix 235 by Master Builders

3.14 QUALITY CONTROL TESTING

- A. Refer to Section 033010 for testing of cast-in-place concrete.

END OF SECTION 033000

SECTION 033010

CONCRETE - GENERAL

PART 1 - GENERAL

1.01 SCOPE

- A. This Section supplements the project drawings and specifies project technical requirements, and defines workmanship, quality control procedures, and identifies governing codes and standards for concrete and concrete materials, ingredients, admixtures and their delivery to the project.

1.02 RELATED DOCUMENTS

- A. The general provisions of the Contract, including General Conditions, Supplementary Conditions and General Requirements apply to the work specified in this section.

1.03 RELATED WORK SPECIFIED ELSEWHERE

- A. Section 033020 - Concrete Formwork
- B. Section 033030 - Concrete Reinforcement
- C. Section 033000 - Cast-In-Place Concrete

1.04 QUALITY ASSURANCE

- A. Codes and Standards: Comply with the provisions of the following codes, specifications and standards, except where more stringent requirements are shown or specified:
 - 1. ACI 211.1-91 "Standard Practice for Selecting Proportions for Normal, Heavyweight, and Mass Concrete."
 - 2. ACI 211.2-91 "Standard Practice for Selecting Proportions for Structural Lightweight Concrete."
 - 3. ACI 214-77 "Recommended Practice for Evaluation of Strength Test Results of Concrete. (Re-approved 1989)"
 - 4. ACI 301-99 "Specifications for Structural Concrete for Buildings."
 - 5. ACI 304R-89 "Guide for Measuring, Mixing, Transporting and Placing Concrete."
 - 6. ACI 305R-91 "Hot Weather Concreting."
 - 7. ACI 309R-96 "Guide for Consolidation of Concrete."
 - 8. ACI 311.4R-95 "Guide for Concrete Inspection."
 - 9. ACI 318-02 "Building Code Requirements for Reinforced Concrete."
 - 10. Florida Building Code 5th Edition 2014

1.05 CONCRETE DEFINITIONS

- A. Aquatic concrete: impervious concrete with low coefficient of permeability and high durability used in members, exterior or interior, which will contain or be in contact with water, salt water or exposed to chlorides in service. This concrete is designed and detailed to be watertight without an elastomeric membrane or liner. Note that acrylic coatings which may be required elsewhere by the Documents do not constitute an elastomeric liner. Aquatic concrete includes the following:
 - 1. all pools, basins, vessels, channels, skimmers, pits,
 - 2. all concrete members located within 10 feet of the above
 - 3. LSS filter area pads

1.06 WORKMANSHIP

- A. The Contractor is responsible for correction of concrete work which does not conform to the specified requirements, including strength, slump, workability, setting time. Correct deficient concrete as directed by the Owner.

1.07 PRE-CONSTRUCTION CONFERENCE

- A. The Contractor is responsible for scheduling a Pre-Construction Conference.
- B. The purpose of the conference is to highlight and discuss concrete aspects contained in this Section and Section 033000 of the Specifications the thorough understanding of which is essential to the success of the Project.
- C. The Agenda for the Pre-Construction Conference will be prepared by the Structural Engineer of Record. All participants will be free to add items for discussion at any time before and during the Conference.
- D. The following participants will attend the Pre-Construction Conference:
 - 1. Owner's representative
 - 2. Testing and Inspection Agency representative
 - 3. Concrete Supplier's representative
 - 4. Concrete Contractor's representative
 - 5. Structural Engineer of Record
- E. Refer to Specification Section 033000 for additional details.
- F. This Pre-Construction Conference may be combined with the conference stipulated in Specification Section 033000.

1.08 PRE-CONSTRUCTION TESTING AND MIX DESIGN

- A. Pre-Construction Material Testing Service: Employ, at Contractor's expense, a testing laboratory acceptable to Owner to perform material evaluation tests and to design concrete mixes and to conduct tests on laboratory trial batches for all classes of concrete. These tests are not part of on-site quality control testing, which is specified as part of Field Quality Control.
- B. Testing agency shall meet the requirements of ASTM E 329.
- C. Materials may require testing and retesting, as directed by the Owner, at any time during the progress of the work. Allow free access to material stockpiles and facilities at all times. Tests, not specifically indicated to be done at Owner's expense, including the retesting of rejected materials including installed work, shall be done at Contractor's expense.
- D. Tests for Concrete Materials:
 - 1. Test aggregates by method of sampling and testing of ASTM C 33.
 - 2. For portland cement, sample the cement and determine the properties by the methods of test ASTM C 150.
 - 3. Test concrete, and submit test reports, for shrinkage length change in accordance with ASTM C 157, with the following modifications:
 - a. Wet cure specimens for a period of 7 days (including the period of time the specimens are in the mold). Wet cure may be achieved either through storage in a moist cabinet or room in accordance with ASTM C 511, or through storage in lime-saturated water.
 - b. Slump of concrete for testing shall match job requirements and need not be limited to restrictions as stated in ASTM C 157, Section 7.4.
 - c. Report results in accordance with ASTM C 157 at 0, 7, 14 and 28 days of drying.
 - 4. Submit written reports to the Owner, for each sample tested, prior to the start of work. Provide the project identification name and number, date of report name of Contractor, name of concrete testing service, source of concrete aggregates, material manufacturer and brand

name for manufactured materials, values specified in the referenced specification for each material, and test results. Indicate whether or not material is acceptable for intended use.

5. Certificates of material properties and compliance with specified requirements may be submitted in lieu of testing, when acceptable to the Owner. Certificates of compliance must be signed by the materials producer and the Contractor.

1.09 SUBMITTALS

- A. **Manufacturer's Data:** Submit manufacturer's product data and specifications with application and installation instructions for proprietary materials and items, including admixtures, curing compounds, patching compounds, and others as requested by the Architect.
- B. **Laboratory Test Reports:** Submit two copies of laboratory test reports for pre-construction testing of concrete materials and mix design, as specified.
- C. **Material Certificates:** Provide materials certificates in lieu of materials laboratory test reports only when permitted by the Architect. Material certificates shall be signed by the manufacturer and the Contractor, certifying that each material item complies with, or exceeds, the specified requirements.
- D. **Submit Contractor's proposed method of concrete placement** when submitting mix designs. When a pump mix is submitted, indicate the design slump of the as-delivered concrete and the anticipated slump at the point of placement.

PART 2 - PRODUCTS

2.01 CONCRETE MATERIALS

- A. **Portland Cement:** ASTM C 150, Type I. Use only one brand of cement throughout the project unless otherwise acceptable to the Owner.
- B. **Normal Weight Aggregates:**
 1. ASTM C 33, and as herein specified. Provide aggregates from a single source for all exposed concrete.
 2. Do not use aggregates containing soluble salts or other substances such as iron sulfides, pyrite, marcasite or ochre, which can cause stains on exposed concrete surfaces.
 3. Local aggregates not complying with ASTM C 33 but which have shown by special test or actual service to produce concrete of adequate strength or service and durability may be used when acceptable to the Owner.
- C. **Aggregate:**
 1. Clean, sharp, natural sand free from loam, clay, lumps, or other deleterious substances.
 2. Dune sand, bank-run sand and manufactured sand are not acceptable.
- D. **Coarse Aggregates:**
 1. Clean, uncoated, processed aggregate containing no clay, mud, loam or foreign matter, as follows:
 - a. Crushed stone, processed from natural rock or stone.
 - b. Washed gravel, either natural or crushed. Use of pit or bankrun gravel is not permitted.
 2. **Maximum Aggregate Size:** Not larger than one-fifth of the narrowest dimension between sides of forms, one-third of the depth of slabs, nor three-fourths of the minimum clear spacing between individual reinforcing bars or bundle of bars.
- E. **Supply of Aggregates:** Use aggregates from one source of supply to ensure uniformity in color, size and shape.
- F. **Pozzolans:** Flyash, Class F, per ASTM C 618, allowed on a one-to-one replacement for up to 15% of portland cement content. Class C Flyash may be approved by the Architect for use. Flyash in amounts greater than 20% of the weight of portland cement content is not permitted.
- G. **Water:** Clean, fresh, potable.

2.02 CALCIUM CHLORIDE

- A. Maximum water soluble chloride ion concentrations as a percent by weight of cement, contributed from the ingredients, including cementitious materials, aggregates, water, and admixtures shall not exceed the limits below, when tested in accordance with AASHTO T 260:
1. 0.10% maximum: for concrete members in contact with water or exposed to chlorides in service.

2.03 CONCRETE ADMIXTURES

- A. Air-Entraining Admixture: Conform to ASTM C 260.
1. Air Mix by Euclid Chemical Co.
 2. Daravair Series or Darex II AEA by W. R. Grace Co.
 3. MB AE 90 or Micro Air by Master Builders
 4. AER by Sika Chemical Corp.
- B. Water-Reducing Admixture: Conform to ASTM C 494, Type A.
1. Eucon WR 75 by Euclid Chemical Co.
 2. WRDA Series by W.R. Grace Co.
 3. Daracem - 55 or 65 by W.R. Grace Co.
 4. Polyheed 997 by Master Builders
 5. Plastocrete 161 by Sika Chemical Corp.
- C. High Range Water-Reducing Admixture (superplasticizer): Conform to ASTM C 494, Type F or G:
1. Eucon 37 by Euclid Chemical Corp.
 2. ADVA Flow by W. R. Grace and Company
 3. Pozzolith 400N by Master Builders
 4. Rheobuild 1000 by Master Builders
 5. Sikament by Sika Chemical Corp.
- D. Water-Reducing, Retarding Admixture: Conform to ASTM C 494, Type D.
1. Eucon Retarder 75 by Euclid Chemical Co.
 2. Daratard Series by W. R. Grace Co.
 3. Pozzolith 100-XR by Master Builders.
 4. Plastiment by Sika Chemical Co
- E. Non-Chloride Accelerator: Conform to ASTM C 494, Type C or E.
1. Accelguard 80 by Euclid Chemical Co.
 2. PolarSet by W.R. Grace Co.
 3. Pozzutec 20 by Master Builders
- F. Calcium Chloride: Refer to Paragraph 2.02 for maximum water soluble chloride ion concentrations in concrete, contributed from the ingredients, including admixtures, cementitious materials, aggregates, and water.
- G. Certification: Provide the manufacturer's product data sheets for the proposed admixtures and a letter written by a technical representative of the admixture manufacturer. The letter is to state that the proposed admixtures have been selected specifically for this project based on this specifications, on the intended use of the concrete, and on the chemical compositions of the local materials. In the event any proposed admixture is not specified above, the letter is to provide a brief explanation why the proposed admixture should be considered in lieu of the specified product. Written conformance to above mentioned requirements and the chloride ion content is required and must be submitted by the admixture manufacturer prior to mix design review.

2.04 RELATED MATERIALS

- A. Bonding and Patching Agents.
1. Structural Bonding Compound: Epoxy adhesive, 100% solids, two component material suitable for use on dry or damp surfaces.
 - a. Euco Epoxy #452 by Euclid Chemical Co.

Contract 17-C-00018; Lois Pumping Station Driveway

- b. Sikadur Hi-Mod by Sika Chemical Corp.
- c. Sikadur Armatec 110 by Sika Chemical Corp.

- 2. Patching Compound: 100% solids, suitable for use on dry or damp surface.
 - a. Euco Epoxy # 460 mortar by Euclid Chemical Co.
 - b. Thin Coat by Euclid Chemical Co.
 - c. Sikadur Lo-Mod mortar by Sika Chemical Corp.

- B. Structural Repair Patching Compounds:
 - 1. EMACO S88 CI by Master Builders
 - 2. EMACO S66 CI by Master Builders

- C. Crystalline Waterproofing System, where noted on the drawings:
 - 1. AQUAFIN-IC Slurry by Aquafin, Inc.
 - 2. AQUAFIN MORTAR-IC by Aquafin, Inc.
 - 3. AQUAFIN PLUG-IC by Aquafin, Inc.

2.05 NON-SHRINK GROUT

- A. Furnish one of the following pre-mixed non-shrink non-metallic grouts for all construction where grout is exposed to weather, water or exposed to view in the finished product:
 - 1. Euco N-S by The Euclid Chemical Co
 - 2. Gilco Const. Grout by W.R. Grace & Co.
 - 3. Set-Grout by Master Builders
 - 4. SonogROUT by Sonneborn Building Products Div.
 - 5. 1107 Advantage Grout by Dayton Superior

- B. Furnish one of the following pre-mixed non-shrink metallic grouts for all construction where the grout is not exposed to water, weather or view in the finished product:
 - 1. Supreme Plus by W.R. Grace & Co.
 - 2. Embeco 885 by Master Builders
 - 3. Ferrolith G by Sonneborn Building Products Div.

2.06 PROPORTIONING AND DESIGN OF MIXES

- A. Prepare design mixes for each type and strength of concrete in accordance with applicable provisions of ASTM C 94. Use an independent testing facility acceptable to the Architect for preparing and reporting proposed mix designs. The testing facility shall not be the same as used for field quality control testing unless otherwise acceptable to the Owner.

- B. All concrete shall contain the specified water-reducing admixture, except aquatic concrete for walls, columns and other vertical elements which concrete shall contain the specified high-range water-reducing admixture (superplasticizer). All concrete shall contain the specified air-entraining admixture.

- C. Proportion mixes by either trial batch method or field experience method, using materials to be employed on the project for each class of concrete required, complying with ACI 211.1 for normal weight concrete, and report to the Owner the following:
 - 1. Complete identification of aggregate supply source.
 - 2. Scale weight of each aggregate.
 - 3. Brand, plant location, type and composition of cement.
 - 4. Brand, type and amount of each admixture,
 - 5. Amount of water used in trial mixes.
 - 6. Proportion of each material per cu.yd. of concrete.
 - 7. Gross weight and yield per cu.yd. of trial mixes.
 - 8. Measured slump.
 - 9. Measured air content.
 - 10. Contractor's proposed method of placement.

11. Compressive strengths developed at 7 days and 28 days, from not less than 6 test cylinders cast for each 7 and 28 day test, and for each design mix.
- D. Laboratory Trial Batches:
1. Prepare test specimens in accordance with ASTM C 192 and conduct strength tests in accordance with ASTM C 39, as specified in ACI 301.
 2. Establish a curve showing relationship between water-cement ratio for cement content and compressive strength, with at least 3 points representing batches which produce strengths above and below that required. Use not less than 3 specimens tested at 28 days, or at an earlier age when acceptable to the Owner, to establish each point on the curve.
- E. Submit written reports to the Owner of each proposed mix for each class of concrete at least 15 days prior to the start of work.
- F. Do not begin concrete production until mixes have been approved by the Owner.
- G. Adjustment to Concrete mixes: Contractor may request design mix adjustments when characteristics of materials, job conditions, weather, test results, or other circumstances warrant; at no additional cost to the Owner and as accepted by the Owner. Submit laboratory test data for revised mix design and strength results for the Architect's acceptance before use.
- H. Admixtures:
1. Use air-entraining admixture in all exterior, exposed and aquatic concrete.
 - a. Add air-entraining admixture at the manufacturer's prescribed rate to result in concrete at the point of placement having air content of 5% (±1%) for 1 1/2 inch [4 cm] aggregates and 6% (±1%) for 1 inch [2,5 cm] aggregates, as determined in accordance with ASTM C 231 or C 173. Provide 4% to 6% air content for all other concrete.
 2. Use admixtures for water-reducing and set-control in strict compliance with the manufacturer's directions.
 3. Use the specified Shrinkage Reducing Admixture in all slabs-on-grade concrete of the Concourse.
 - a. Add shrinkage reducing admixture at the manufacturer's prescribed rate or at a dosage rate not to exceed 2.5% by weight of cementitious material.
 - b. Have a representative of the admixture manufacturer present during the initial concrete placement, unless Contractor provides sufficient evidence that Producer and Finisher have adequate experience with admixture required.
 4. Use amounts of admixtures as recommended by the manufacturer for climatic conditions prevailing at the time of placing. Adjust quantities and types of admixtures as required to maintain quality control.

2.07 CLASSIFICATION OF CONCRETE

Use	28-day Strength	Maximum Aggregate Size	W/C ^(*) Ratio	Slump ^(**)
Footings	4,000 psi	#57	N.A.	4" – 6"
Walls	4,000 psi	#57	N.A.	3" – 5"
<u>Aquatic Concrete:</u>				
Base Slabs	5,000 psi	#57	0.40	3" – 5"
Walls, Skimmers, Channel	5,000 psi	#57	0.40	3" – 5"
Pool Deck Retaining Walls	5,000 psi	#57	0.40	3" – 5"
Pits, Basins and Pads	5,000 psi	#57	0.40	3" – 5"
Filter Supports and Pads	5,000 psi	#57	0.40	3" – 5"

- (*) water-cementitious ratio
- (**) except as modified by High Range Water Reducing Admixture

Conversions:	5,000 psi	350 kg/cm ² , 35 MPa
	# 57 aggregate	2,5 cm nominal maximum size
	3" - 5" slump	8 to 12 cm

2.08 WATER-CEMENTITIOUS RATIO

- A. Deliver all concrete with the specified water-cementitious ratio. Submit copies of batch tickets to Owner when requested.
- B. Calculate ratios by weight.
- C. Include in the weight of water the following:
 - 1. weight of batch water
 - 2. weight of moisture on surfaces of coarse and fine aggregate
 - 3. weight of water introduced by all admixtures
 - 4. weight of water to be added at point of delivery
- D. Include in the weight of cementitious materials the following:
 - 1. cement
 - 2. pozzolans, up to 15% of weight of total cementitious materials

2.09 SLUMP

- A. Deliver all concrete containing the high-range water-reducing admixture (superplasticizer), with a slump between 2 and 3 inches [*5 to 8 cm*] upon arrival at the jobsite and a maximum slump of 9 inches [*25 cm*] at the concrete delivery truck discharge point, unless otherwise directed by the Architect, or otherwise indicated in the approved mix design.

PART 3 - EXECUTION

3.01 CONCRETE MIXING AND DELIVERY

- A. Concrete may be mixed at batch plants or it may be transit-mixed as herein specified. Batch plants must comply with the requirements of ACI 304, with sufficient capacity to produce concrete in the quantities required to meet the construction schedule. All plant facilities are subject to testing laboratory inspection and acceptance of the Owner.
- B. Comply with the requirements of ASTM C 94, and as herein specified, provided the quantity and rate of delivery will permit unrestricted progress of the work in accordance with the concrete placement schedule. During hot weather, or under conditions contributing to rapid setting of concrete, a shorter mixing time than specified in ASTM C 94 may be required, as specified below. Proposed changes in mixing procedures, other than those herein specified, must be accepted by the Architect before implementation.
- C. Plant equipment and facilities: Conform to National Ready-Mix Concrete Association "Checklist for Certification of Ready-Mix Concrete Production Facilities".
- D. Modification to ASTM C 94 are as follows:
 - 1. Quality of Concrete: Use concrete materials, proportions, and properties as herein specified, in lieu of Section 4.
 - 2. Tolerances in Slump: Use slump within the ranges as herein specified, in lieu of Section 6.1. Comply with other criteria of Section 6.
 - 3. Mixing and Delivery: Delete the reference for allowing additional water to be added to the batch for material with sufficient slump. Addition of water to the batch will not be permitted as specified in Section 11.7, but may be permitted only upon the Architect's approval. In addition to the requirements of Section 11.7, when the air temperature is between 85E F. [*30E C*] and

90E F. [33E C], reduce the mixing and delivery time from 90 minutes to 75 minutes, and when air temperature is above 90E F. [33E C], reduce the mixing and delivery time to 60 minutes. When a truck mixer is used for the complete mixing of concrete, begin the mixing operation within 30 minutes after the cement has been intermixed with the aggregates.

- E. Submit duplicate batching tickets with each load of concrete delivered to the site, one for the Owner and one for the Contractor. In addition to the requirements of ASTM C 94 Section 16.1, provide the following information on batching tickets:
1. Type and brand of cement.
 2. Cement content per cu.yd. of concrete.
 3. Quantities and maximum size of aggregate.
 4. Total water in gallons and expressed as water/cementitious materials ratio.
 5. Quantities of all admixtures, including air entrainment and fly ash.

3.02 STRENGTH

- A. Delete ASTM C 94 Section 17; comply with concrete testing requirements as herein specified.

3.03 DELIVERY EQUIPMENT

- A. Maintain equipment in proper operating condition, with drums cleaned before charging each batch. Schedule rates of delivery in order to prevent delay of placing the concrete after mixing, or holding dry-mixed materials too long in the mixer before the addition of water and admixtures.

3.04 FIELD QUALITY CONTROL

- A. The owner will employ a separate testing laboratory to perform field quality control testing and to submit test reports.
- B. Quality Control Testing During Construction: Sampling and testing for quality control during the placement of concrete include the following, as directed by the Owner:
1. Sampling Fresh Concrete: ASTM C 172, except modified for slump to comply with ASTM C 94.
 2. Slump: ASTM C 143; one test for each concrete load at point of discharge; and one test for each set of compressive strength test specimens.
 3. Air content: ASTM C 173, volumetric method for lightweight concrete; ASTM C 231 pressure for normal weight concrete; one test for every other concrete load at the point of discharge, or when the indication of change requires.
 4. Concrete Temperature: Test hourly when air temperature is 40E F. [4E C] and below, and when 80E F. [25E C] and above; and each time a set of compression test specimens are made.
 5. Compression Test Specimen: ASTM C 31; one set of five standard cylinders for each compressive strength test, unless otherwise directed. Mold and store cylinders for laboratory cured test specimens except when field-cure test specimens are required.
 6. Compressive Strength Tests:
 - a. ASTM C 39; one set for each 100 cu. yds. [70 m³] or fraction thereof, of each concrete class placed in any one day for each 5,000 sq. ft. [450 m²] of surface area placed; 1 specimen tested at 7 days, 3 specimens tested at 28 days, and one specimen retained in reserve for later testing if required.
 - b. When the frequency of testing will provide less than 5 strength tests for a given class of concrete, conduct testing from at least 5 randomly selected batches or from each batch if fewer than 5 are used.
 - c. When the total quantity of a given class of concrete is less than 50 cu. yds., the strength test may be waived by the Architect if, in his/her judgment, adequate evidence of satisfactory strength is provided.
 - d. When the strength of field cured cylinders is less than 85% of companion laboratory cured cylinders, evaluate current operations and provide corrective procedures for protecting and curing the in-place concrete.

- e. Test results will be reported in writing to the Architect and the Contractor on the same day that tests are made.
 - f. Reports of compressive strength tests shall contain the project identification name and number, date of concrete placement, name of concrete testing service, concrete type and class, location of concrete batch in the structure, design compressive strength at 28 days, concrete mix proportions and materials; compressive breaking strength and type of break for both 7 day and 28 day tests.
- C. Additional Tests: The testing service will make additional tests of in-place concrete when test results indicate the specified concrete and other characteristics have not been attained in the structure, as directed by the Architect. The testing service may conduct tests to determine adequacy of concrete by cored cylinders complying with ASTM C 42 or by other methods as directed. Contractor shall pay for such tests as may be required, when unacceptable concrete is verified.

3.05 EVALUATION OF QUALITY CONTROL TESTS

- A. Do not use concrete delivered to the final point of placement which has slump or total air content outside the specified values.
- B. Compressive strength tests for laboratory-cured cylinders will be considered satisfactory if the averages of all sets of three consecutive compressive strength test results equal or exceed the 28-day design compressive strength of the type of class of concrete, and if no individual strength test falls below the required compressive strength by more than 500 psi [35 kg/cm^2 , $3,5 \text{ MPa}$].
- C. Strength test of specimens cured under field conditions may be required by Architect to check the adequacy of curing and protection of already placed concrete. Specimens shall be molded by the field quality control laboratory at the same time and from the same samples as the laboratory-cured specimens.
- D. Improve means and procedures for curing and protecting concrete when the 28-day compressive strength of field-cured cylinders is less than 85% of companion laboratory-cured specimens.
- E. If individual test of laboratory-cured specimens produce strengths more than 500 psi [35 kg/cm^2 , $3,5 \text{ MPa}$] below the required minimum compressive strength, or if tests of field-cured cylinders indicate deficiencies in protection and curing, use additional measures to assure that the load-bearing capacity of the structure is not less than that intended by design.

END OF SECTION 033010

SECTION 033020

CONCRETE FORMWORK

PART 1 - GENERAL

1.01 SCOPE

- A. This Section supplements the Drawings and specifies project technical requirements, and defines workmanship, quality control procedures, and identifies governing codes and standards for formwork, and the design, installation and removal of shoring and reshoring for cast-in-place concrete structural components of this Project.

1.02 RELATED DOCUMENTS

- A. The provisions of the Contract, including General Contract Conditions and General Requirements apply to the work specified in this Section.

1.03 RELATED WORK SPECIFIED ELSEWHERE

- A. Section 033030 - Concrete Reinforcement
- B. Section 033010 - Concrete - General
- C. Section 033000 - Cast-In-Place Concrete

1.04 QUALITY ASSURANCE

- A. Comply with the requirements of the latest edition of the following codes, specifications and standards, except where more stringent requirements are shown or specified:
 - 1. American Concrete Institute ACI 347R-94 - "Guide to Formwork for Concrete."
 - 2. U.S. Department of Commerce: U.S. Voluntary Product Standard PS 1-83 "Construction and Industrial Plywood."
- B. Design, construct, erect, maintain and remove forms and related structures for cast-in-place concrete work in compliance with ACI 347.

1.05 ALLOWABLE TOLERANCES

- A. Construct formwork to provide completed cast-in-place concrete surfaces complying with the tolerances specified in ACI 347 and as follows:
 - 1. Variation from level or grade in slab surfaces, ceilings, beam soffits and in arrises: 1/4 inch [5 mm] in 10 feet [3 m], 3/8 inch [10 mm] in any bay or 20 feet [6 m] maximum, and 3/4 inch [20 mm] in 40 feet [12 m] or more. For exposed sills, horizontal grooves and other conspicuous lines: 1/4 inch [5 mm] in any bay or 20 feet [6 m] maximum and 1/2 inch [10 mm] in 40 feet [12 m] or more.
 - 2. Variation from position of the linear building lines and related columns: 1/2 inch [10 mm] in any bay or 20 feet [6 m] maximum, and 1 inch [25 mm] in 40 feet [12 m] or more.
 - 3. Variation in sizes and locations of sleeves, floor openings and wall openings: 1/4 inch [5 mm].
 - 4. Variation in thickness of slabs and walls: minus 1/4 inch [5 mm] and plus 1/2 inch [10 mm].
 - 5. Variation in footing plan dimensions: minus 1/2 inch [10 mm] and plus 2 inches [50 mm]; misplacement or eccentricity: 2% of the footings width in direction of misplacement but not more than 2 inches [50 mm]; thickness reduction: minus 5%.

0.1 INSPECTION

- A. Before concrete placement: check the lines and levels of erected formwork. Make corrections and adjustments to ensure proper size and location of concrete members and stability of forming systems.
- B. During concrete placement: check formwork and related supports to ensure that forms are not displaced and that completed work will be within specified tolerances.

PART 2 - PRODUCTS

2.01 FORM MATERIALS

- A. Forms for Exposed Finish Concrete: Unless otherwise indicated, construct formwork for exposed concrete surfaces with plywood, metal, metal-framed, plywood-faced or other type panel materials to provide continuous, straight, as-cast surfaces. Furnish in largest practicable sizes to minimize number of joints and to conform to joint system on the Drawings. Provide form material with sufficient thickness to withstand pressure of placed concrete without bow or deflection beyond allowable tolerances.
- B. Use overlaid plywood complying with U.S. Product Standard PS-1, "B-B High Density Overlaid Concrete Form", Class 1, or "B-B Plyform", Class 1, at architecturally exposed surfaces.
- C. Forms for Unexposed Finish Concrete: Form concrete surfaces which will be unexposed in the finish structure with plywood, lumber, metal, or other acceptable material. Provide lumber that is dressed on at least 2 edges and 1 side for tight fit.

2.02 FORM TIES

- A. Provide factory-fabricated, adjustable-length, removable or snap-off form ties, designed to prevent deflection, and to prevent spalling concrete surfaces upon removal.
- B. Unless otherwise indicated, provide form ties which will leave a hole with a diameter equal to $\frac{1}{2}$ to $\frac{2}{3}$ of the break-back point distance in the concrete surfaces. Provide ties so that portion remaining within concrete after removal of exterior parts is distant from the outer concrete surface by the following minimum amounts:
 - 3 inches [7.5 cm] for all aquatic concrete

2.03 FORM COATINGS

- A. Provide V.O.C. compliant commercial formulation form-coating compounds that will not bond with, stain nor adversely affect concrete surfaces, and will not impair subsequent treatment of concrete surfaces requiring bond or adhesion nor impede the wetting of surfaces to be cured with water or curing compounds.
 - 1. V.O.C. content shall be a maximum 2.8 lbs/gal. [340 gm/liter], unless more stringent codes or laws apply.

2.04 INSERTS

- A. Provide inserts and other embedded items as required for anchorage of materials or equipment to concrete construction, not supplied by other trades and as required for the work.

2.05 DESIGN OF FORMWORK

- A. Design, erect, support, brace and maintain formwork so that it will safely support vertical and lateral loads that might be applied, until such loads can be supported by the concrete structure. Carry vertical and lateral loads to the ground by formwork system and in-place construction that has attained adequate strength for that purpose.
- B. Design formwork to be readily removable without impact, shock or damage to cast-in-place concrete surfaces and adjacent materials.
- C. Provide formwork sufficiently tight to prevent leakage of cement paste during concrete placement. Solidly butt joints and provide backup material at joints as required to prevent leakage and fins.

PART 3 - EXECUTION

3.01 INSPECTION

- A. The installer must examine the substrate and the conditions under which concrete formwork is to be performed and notify the Contractor in writing of unsatisfactory conditions. Do not proceed with the work until unsatisfactory conditions have been corrected in a manner acceptable to the Installer.

3.02 FORM CONSTRUCTION

- A. Construct forms complying with ACI 347, to the sizes, shapes, lines, and dimensions shown and as required to obtain accurate alignment, location, grades, level, and plumb work in finished structure. Provide for openings, offsets, sinkages, keyways, recesses, chamfers, blocking, screeds, bulkheads, anchorages, and inserts and other features required. Use selected materials to obtain required finishes.
- B. Fabricate forms for easy removal without hammering or prying against concrete surfaces. Provide crush plates or wrecking plates where stripping may damage cast concrete surfaces. Provide top forms for inclined surfaces where the slope is too steep to place concrete with bottom forms only. Kerf wood inserts for forming keyways, reglets, recesses and the like, to prevent swelling and assure ease of removal.
- C. Form intersecting planes to provide true, clean-cut corners, with edge of plywood not exposed as form for concrete.
- D. Correct conditions which could cause an unsatisfactory finished product. If conditions are severe enough to endanger the safety of personnel in the area, stop the concrete placement until the unsafe condition has been corrected.
- E. When temporary drilled-in anchors are used to facilitate supporting or bracing of forms, the embedment of such inserts into previously placed and hardened concrete is limited to 2½ inches. Fill all holes left by such drilled-in anchors with a patching compound specified in Section 03300.

3.03 FORMS FOR EXPOSED CONCRETE

- A. Drill forms to suit ties used and to prevent leakage of concrete mortar around tie holes. Do not splinter forms by driving ties through improperly prepared holes.
- B. Do not use metal cover plates for patching holes on defects in forms.
- C. Provide sharp, clean corners at intersecting planes, without visible edges or offsets. Back joints with extra studs or girts to maintain true square intersections.
- D. Use extra studs, walers and bracing to prevent bowing of forms between studs and to avoid bowed appearance in concrete. Do not use narrow strips to form materials which will produce bow.
- E. Assemble forms so they may be readily removed without damage to exposed concrete surfaces.
- F. Form chamfers with 3/4 inch x 3/4 inch [2 cm x 2 cm] strips, accurately formed and surfaced to produce uniformly straight lines and tight edge joints. Extend terminal edges to required limit and miter chamfer at changes in direction.
- G. See 03300-Series Sections for treatment of control and construction joints, including wood screeds, metal keyways and saw cuts. Locate as indicated or specified.

3.04 PROVISIONS FOR OTHER TRADES

- A. Provide openings in concrete formwork to accommodate work of other trades, including those under separate prime contracts (if any). Size and location of openings, recesses and chases are

the responsibility of the trade requiring such items. Accurately place and securely support items to be built into forms.

3.05 CLEANING AND TIGHTENING

- A. Thoroughly clean forms and adjacent surfaces to receive concrete. Remove chips, wood, sawdust, dirt or other debris just before concrete is to be placed. Re-tighten forms immediately after concrete placement as required to eliminate mortar leaks.

3.06 FORM COATINGS

- A. Coat form contact surfaces with form-coating compound before reinforcement is placed. Do not allow excess form coating material to accumulate in the forms or to come into contact with reinforcement or surfaces which will be bonded to fresh concrete. Apply in compliance with manufacturer's instructions.
- B. Coat steel forms with a non-staining, rust-preventative form oil or otherwise protect against rusting. Rust-stained steel formwork is not acceptable.

3.07 EMBEDDED ITEMS

- A. Set and build into the work anchorage devices and other embedded items required for other work that is attached to, or supported by, cast-in-place concrete. Use setting drawings, diagrams, instructions and directions provided by suppliers of the items to be attached thereto.

3.08 EDGE FORMS AND SCREED STRIPS FOR SLABS

- A. Set edge forms or bulkheads and intermediate screed strips for slabs to obtain required elevations and contours in the finished slab surface. Provide and secure units to support types of screeds required.

3.09 REMOVAL OF FORMS

- A. Formwork not supporting concrete, such as sides of walls, may be removed after cumulatively curing at not less than 50 degrees F. for 24 hours after placing concrete; provided concrete is sufficiently hard to not be damaged by form removal operations and provided that curing and protection operations are maintained.

3.10 RE-USE OF FORMS

- A. Clean and repair surfaces of forms to be re-used in the work. Split, frayed, delaminated or otherwise damaged form facing material will not be acceptable. Apply new form coating compound material to concrete contact surfaces as specified for new formwork.
- B. When forms are extended for successive concrete placements, thoroughly clean surfaces, remove fins and laitance, and tighten forms to close all joints. Align and secure joints to avoid offsets. Do not use "patched" forms for exposed concrete surfaces, except as acceptable to the Owner.

END OF SECTION 033020

SECTION 033030

CONCRETE REINFORCEMENT

PART 1 - GENERAL

1.01 SCOPE

- A. This Section supplements the Drawings and specifies project technical requirements, and defines workmanship, quality control procedures, and identifies governing codes and standards for fabrication, placement, supports, inspection and final acceptance of reinforcing for the cast-in-place concrete structural components of this Project.

1.02 RELATED DOCUMENTS

- A. The general provisions of the Contract, including General Contract Conditions and General Requirements apply to the work specified in this Section.

1.03 RELATED WORK SPECIFIED ELSEWHERE

- A. Section 033020 - Concrete Formwork
- B. Section 033010 - Concrete - General
- C. Section 033000 - Cast-in-place Concrete

1.04 QUALITY ASSURANCE

- A. Codes and Standards: Comply with requirements of the latest edition of the following codes, specifications and standards, except where more stringent requirements are shown or specified:
 - 1. American Welding Society, (AWS) D1.4 "Structural Welding Code - Reinforcing Steel."
 - 2. Concrete Reinforcing Steel Institute, (CRSI):
 - a. "Manual of Standard Practice"
 - b. "Placing Reinforcing Bars"
 - 3. American Concrete Institute
 - a. ACI 315-99 "Details and Detailing of Concrete Reinforcement."
 - b. ACI 318-99 "Building Code Requirements for Reinforced Concrete."
 - c. SP-66 "ACI Detailing Manual - 1994."
 - 4. Florida Building Code 5th Edition 2014

1.05 SUBMITTALS

- A. Submit under the provisions of Section 01300, Submittals.
- B. Shop Drawings: Submit shop drawings for fabrication, bending and placement of concrete reinforcement. Comply with the SP-66. Show bar schedules, stirrup spacing, diagrams of bent bars, arrangements and assemblies, type and quantity of bar supports, as required for the fabrication and placement of concrete reinforcement.

1.06 DELIVERY, STORAGE AND HANDLING

- A. Deliver reinforcement to the project site bundled, tagged and marked. Use durable, permanently marked tags indicating bar size, lengths and other information corresponding to markings shown on placement diagrams.
- B. Store concrete reinforcement materials at the site to prevent damage and accumulation of dirt or excessive rust.

PART 2 - PRODUCTS

2.01 MATERIALS

- A. Reinforcing Bars: ASTM A 615, Including Supplement S1, Grade 60 for all sizes.
- B. Welded Wire Fabric: ASTM A 185, flat sheets only.
- C. Supports for Reinforcement: Bolsters, chairs, spacers and other devices for spacing, supporting and fastening reinforcement in place.
 - 1. Use wire bar type supports complying with CRSI recommendations, unless otherwise indicated. Do not use wood, brick and other unacceptable materials, except as permitted herein.
 - 2. For footings and mats whose minimum thickness is 10 inches, use concrete brick supports of adequate thickness for the clearances specified.
 - 3. For exposed-to-view concrete surfaces, where legs of supports are in contact with forms, provide supports with plastic-tipped legs.
 - 4. For concrete surfaces exposed to fresh water, fresh water spray and/or rain in the finished project, and for surfaces which will be sandblasted, use supports with stainless steel legs. Welded stainless steel leg tips are unacceptable.
 - 5. For all aquatic concrete and for other concrete surfaces exposed to salt water or salt water spray in the finished project, use stainless steel bar supports. Welded stainless steel leg tips are unacceptable.
 - 6. Over waterproof membranes, use concrete brick supports to prevent penetration of the membrane.

2.02 WELDING OF REINFORCING BARS

- A. Do not weld reinforcing bars.
- B. Do not weld stirrups, ties, inserts or other similar elements to longitudinal reinforcing bars.
- C. Metal filled sleeves or mechanical butt splices in which filler metal interlocks the grooves inside the splice sleeve with the reinforcing bar deformations may be used with the Owner's approval. Mechanical butt splices shall develop the full reinforcing bar section in compression and the specified ultimate tensile strength of the reinforcing bars.

2.03 FABRICATION

- A. Fabricate reinforcing bars to conform with required shapes and dimensions, with fabrication tolerances complying with CRSI "Manual of Standard Practice" and with ACI 315. In case of fabricating errors, do not re-bend or straighten reinforcement in a manner that will injure or weaken the material.
- B. Unacceptable Materials: Reinforcement with any of the following defects will not be permitted in the work:
 - 1. Bar lengths, depths and bends exceeding CRSI fabrication tolerances.
 - 2. Bends or kinks not indicated on the Drawings or final shop drawings.
 - 3. Bars with cross-section reduced by excessive rusting or other causes.

PART 3 - EXECUTION

3.01 INSTALLATION

- A. Comply with the specified codes and standards and Concrete Reinforcing Steel Institute's recommended practice for "Placing Reinforcing Bars", for details and methods of reinforcement placement and supports, and as herein specified.
- B. Clean reinforcement to remove loose rust, mill scale, earth, and other materials which reduce or destroy bond with concrete.

Contract 17-C-00018; Lois Pumping Station Driveway

- C. Accurately position, support and secure reinforcement against displacement by formwork, construction or concrete placement operations. Locate and support reinforcing steel by use of metal chairs, runners, bolsters, spacers, or hangers, as required. In cases such as in trench footings, mat foundations, and thick slabs, support top layer of reinforcing with rebar bent in a type 25 standard bending pattern.
- D. Place reinforcement to obtain the minimum coverages for concrete protection. Arrange, space and securely tie bars and bar supports together with 16 gage black-annealed wire to hold reinforcement accurately in position during concrete placement operations. Set wire so that wire ends are directed away from exposed concrete surfaces with a clearance equal to that of the main reinforcing steel.
- E. Install welded wire fabric in as long lengths as practicable. Lap adjoining pieces at least one full mesh, or 8 inches minimum, and lace splices with 16 gage wire. Offset end laps in adjacent widths to prevent continuous laps.

3.02 SUPPORTING REINFORCING STEEL

- A. Install sufficient numbers of supports and of strengths to carry reinforcement. Do not place reinforcing bars more than 6" beyond the last leg of any continuous bar support. Do not use supports as bases for runways for concrete conveying equipment and similar construction loads.

3.03 SPLICES

- A. Install standard reinforcement splices by lapping ends, placing bars in contact and tying tightly with wire. Comply with requirements of ACI 315 and ACI 318 for minimum lap of spliced bars, except where longer laps are shown on the Drawings.

END OF SECTION 033030

SECTION 31 10 04
SUB-SURFACE CONDITIONS

PART 1 - GENERAL

1.1 DESCRIPTION

- A. Exploratory borings were obtained only for the Owner's use and are included in the projects documents.

1.2 QUALITY ASSURANCE

- B. Testing Agency:
 - 1. Testing agency and soils Engineer will be retained by General Contractor to provide testing and continuous inspection of work in connection with excavating, filling, compacting and grading.
 - 2. Refer to other sections of the Specifications for specific requirements of required testing and submittals required.

1.3 JOB CONDITIONS

- C. The Contractor shall visit the site and acquaint himself with all existing conditions. Prior to bidding, bidders may make their own sub-surface investigations to satisfy themselves as to site and sub-surface conditions, but such sub-surface investigations shall be performed only under time schedules and arrangements approved in advance by the Owner.

PART 2 - PRODUCTS (NOT USED)

PART 3 - EXECUTION

1.4 PERFORMANCE

- A. All work relative to sub-surface conditions shall be accomplished in accordance with the specific requirements of the individual sections of the Specifications.
- B. Readjust all work performed which does not meet technical or design requirements as hereinafter specified, but make no deviations from the Contract Documents without specific and written approval of the Owner and Engineer.

END OF SECTION

SECTION 31 11 00
EARTHWORK

PART 1 - GENERAL

1.1 SCOPE OF WORK

- A. Excavate, fill, compact and grade all embankments, subgrades, shoulders, ditches and side slopes in accordance with the alignment, grades and cross-sections shown or reasonably implied in the Drawings. Work shall include furnishing fill (borrow) material and hauling and disposal of unsuitable materials as required.

PART 2 - MATERIALS

2.2 SUITABLE MATERIAL

- A. Fill or backfill material obtained from the construction efforts and borrow areas, must consist of clean sand or sand/clay having less than 5% organic content and less than 10% fines passing the #200 sieve.

2.3 UNSUITABLE MATERIAL

- A. Muck, stumps, clay, roots, rock, vegetable matter, rubbish, or other material which is located within pavement, pool, building or any embankment areas, shall be removed.

3 EXECUTION

3.1 REMOVAL OF UNSUITABLE MATERIALS

- A. Excavate and replace all unsuitable materials to obtain an enduring foundation.

3.2 DISPOSAL OF SURPLUS & UNSUITABLE MATERIAL

- A. Ownership of all suitable materials shall remain with the Owner until the final job requirements for fill or backfill materials have been fulfilled. Unless otherwise provided, any surplus materials then remaining and not needed for job requirements shall become the property of Contractor and are to be disposed of by him. Where temporary storage of apparent excess suitable materials within the project site may be impracticable, Contractor may stockpile the materials outside the project site in equally suitable material, at his own expense.
- B. Excavated muck or other materials unsuitable for construction shall become the property of Contractor and shall be disposed of by him off the project site.

3.3 DISPOSAL OF PAVING MATERIALS

- A. Unless otherwise indicated in the Drawings, paving materials excavated in the removal of existing pavements, such as asphalt, block, concrete slab, limerock, sidewalk, curb and gutter, etc., shall become the property of Contractor and shall be disposed of by him off the project site.

3.4 BORROW

- A. Should there be insufficient satisfactory material available from the excavation to meet the requirements for fill material, and where borrow sites are not provided in the Contract Documents, borrow sites and material shall be secured by Contractor at no additional expense to the Owner.

3.5 DISPOSAL AREAS

- A. Where the plans or specifications require Contractor to dispose of excavated materials off the project site, and the disposal area is not indicated in the Contract Documents, Contractor shall furnish the disposal area without additional compensation.

3.6 EARTHWORK CONSTRUCTION

- A. In advance of the placement of any fill, scarify the surface to a depth of a least 6" until the surface is free from uneven features which would prevent uniform compaction by construction equipment. Additionally, prior to placing fill, Contractor shall proof-roll scarified surface by means of several

overlapping passes of a heavy vibratory roller to detect areas of unsuitable or yielding soil. Proof-rolling shall achieve a minimum of 95% of maximum (AASHTO T-180) density. Place successive layers of fill not more than 12" in thickness, measured loose, then compact it continuously to a minimum density of 95% of maximum (AASHTO T-180) density, except that 98% is required for the top 1' for pavement, building and pool areas. Designated landscaped, non-traffic bearing areas shall be exempt from these proof-rolling and compaction requirements but shall receive minimum 90% compaction to achieve a relatively unyielding surface condition.

3.7 MAINTENANCE AND PROTECTION OF WORK

- A. Maintain all earthwork construction throughout the life of the Contract and take all reasonable precautions as well as any precautions prescribed in Permits for this project to prevent loss of material from the site due to the action of wind or water. Except as otherwise provided, Contractor shall repair at his expense any slides, washouts, settlements, subsidence, or other mishap which may occur prior to final acceptance of work.

3.8 FINAL GRADE TOLERANCES

- A. Shape the earthwork to conform to lines, grades and cross-sections shown in the Drawings with the following tolerances: all earth shoulders, slopes, and side ditches shall be completed and shaped to a surface which is within 0.1' of the true surface on the Drawings, except that adjacent to pavement, curb, or sidewalk the finish grade shall match the edge of pavement, curb or sidewalk. However, if sod is to be placed adjacent to pavement, curbs or sidewalks, final grading shall allow the top of sod soil mat to be flush with top edge of pavement, curb or sidewalk.

3.9 TESTING

- A. Provide density testing, for each vertical lift, at intervals not to exceed 250 feet for roadways or 10,000 square feet for parking and beach areas.

END OF SECTION

SECTION 31 11 10
EARTHWORK FOR STRUCTURES

PART 1 - GENERAL

1.1 RELATED DOCUMENTS

- A. Drawings and general provisions of the Contract, including General and Supplementary Conditions and Division 1 Specification Sections, apply to work of this section.

1.2 DESCRIPTION OF WORK

- A. The extent of earthwork is shown on drawings.
 - 1. Preparation of subgrade for slabs, walks and backfilling of trenches adjacent to the building is included as part of this work. Coordinate with other trades.

1.3 QUALITY ASSURANCE

- A. Codes and Standards:
 - 1. Perform excavation work in compliance with applicable requirements of governing authorities having jurisdiction.
- B. Testing and Inspection Service:
 - 1. All soil testing shall be paid by the Owner.

1.4 SUBMITTALS

- A. Test Reports - Excavating:
 - 1. Submit following reports directly to Architect from the testing services, with copy to Contractor:
 - 2. Test report on borrow material.
 - 3. Verification of each footing subgrade.
 - 4. Field density test reports.
 - 5. One optimum moisture-maximum density curve for each type of soil encountered.
 - 6. Report of actual unconfined compressive strength and/or results of bearing tests of each strata tested.

1.5 JOB CONDITIONS

- A. Site Information:
 - 1. Data on indicated subsurface conditions are not intended as representations or warranties of accuracy of continuity between soil borings. It is expressly understood that Owner will not be responsible for interpretations or conclusions drawn there from by Contractor. Data are made available for convenience of Contractor. A copy of the

soil boring report is attached to these specifications for reference only.

2. Additional test borings and other exploratory operations may be made by Contractor at no cost to Owner.

B. Existing Utilities:

1. Locate existing underground utilities in areas of work. If utilities are to remain in place, provide adequate means of protection during earthwork operations.
2. Should uncharted, or incorrectly charted, piping or other utilities be encountered during excavation, consult utility owner immediately for directions. Cooperate with Owner and utility companies in keeping respective services and facilities in operation. Repair damaged utilities to satisfaction of utility owner.
3. Demolish and completely remove from site existing underground utilities indicated to be removed.

C. Use of Explosives:

1. The use of explosives is not permitted.

D. Protection of Persons and Property:

1. Barricade open excavations occurring as part of this work and post with warning lights.
2. Operate warning lights as recommended by authorities having jurisdiction.
3. Protect structures, utilities, sidewalks, pavements and other facilities from damage caused by settlement, lateral movement, undermining, washout and other hazards created by earthwork operations.

PART 2 - PRODUCTS

2.1 SOIL MATERIALS

A. Definitions:

1. Satisfactory soil materials are defined as those complying with American Association of State Highway and Transportation Officials (AASHTO) M145, soil classification Groups A-1, A-2-4, A-2-5 and A-3.
2. Unsatisfactory soil materials are those defined in AASHTO M145 soil classification Groups A-2-6, A-2-7, A-4, A-5, A-6 and A-7; also peat and other highly organic soils.
3. Backfill and Fill Materials: Satisfactory soil materials free of clay, rock or gravel larger than 2" in any dimension, debris, waste, vegetable and other deleterious matter.

PART 3 - EXECUTION

3.1 EXCAVATION

- A. Excavation consists of removal and disposal of material encountered when establishing required finish grade elevations.
- B. Excavation includes removal and disposal of pavements and other obstructions visible on ground surface, underground structures and utilities indicated to be demolished and removed, material of any classification indicated in data on subsurface conditions, and other materials encountered that are not classified as rock excavation or unauthorized excavation.
- C. Unauthorized excavation consists of removal of materials beyond indicated subgrade elevations or dimensions without specific direction of Architect. Unauthorized excavation, as well as remedial work directed by Architect, shall be at Contractor's expense.
 - 1. Under footings, foundation bases, or retaining walls, fill unauthorized excavation by extending indicated bottom elevation of footing or base to excavation bottom without altering required top elevation. Lean concrete fill may be used to bring elevations to proper position when acceptable to Architect.
 - 2. Elsewhere, backfill and compact unauthorized excavations as specified for authorized excavations of same classification, unless otherwise directed by Architect.
- D. Additional Excavation:
 - 1. If unsuitable bearing materials are encountered at required subgrade elevations, carry excavations deeper and replace excavated material as directed by Architect.
- E. Stability of Excavations:
 - 1. Slope sides of excavations to comply with local codes and ordinances having jurisdiction. Shore and brace where sloping is not possible because of space restrictions or stability of material excavated.
 - 2. Maintain sides and slopes of excavations in safe condition until completion of backfilling.
- F. Shoring and Bracing:
 - 1. Provide materials for shoring and bracing, such as sheet piling, uprights, stringers and cross-braces, in good serviceable condition.
 - 2. Establish requirements for trench shoring and bracing to comply with local codes and authorities having jurisdiction.
 - 3. Maintain shoring and bracing in excavations regardless of time period excavations will be open. Carry down shoring and bracing as excavation progresses.
- G. Dewatering:
 - 1. Prevent surface water and subsurface or ground water from flowing into excavations and from flooding project site and surrounding area.

2. Do not allow water to accumulate in excavations. Remove water to prevent softening of foundation bottoms, undercutting footings, and soil changes detrimental to stability of subgrades and foundations. Provide and maintain pumps, well points, sumps, suction and discharge lines, and other dewatering system components necessary to convey water away from excavations.
3. Convey water removed from excavations and rain water to collecting or runoff areas. Establish and maintain temporary drainage ditches and other diversions outside excavation limits for each structure. Do not use trench excavations as temporary drainage ditches.

H. Material Storage:

1. Stockpile satisfactory excavated materials where directed, until required for backfill or fill. Place, grade and shape stockpiles for proper drainage.
2. Locate and retain soil materials away from edge of excavations.
3. Dispose of excess soil material and waste materials as herein specified.

I. Excavation for Structures:

1. Conform to elevations and dimensions shown within a tolerance of plus or minus 0.10', and extending a sufficient distance from footings and foundations to permit placing and removal of concrete form work, installation of services, other construction, and for inspection.
2. In excavating for footings and foundations, take care not to disturb bottom of excavation. Excavate by hand to final grade just before concrete reinforcement is placed. Trim bottoms to require lines and grades to leave solid base to receive other work.

J. Excavation for Trenches:

1. Dig trenches to the uniform width required for particular item to be installed, sufficiently wide to provide sample working room.
2. Excavate trenches to depth indicated or required. Carry depth of trenches for piping to establish indicated flow lines and invert elevations. Beyond building perimeter, keep bottoms of trenches sufficiently below finish grade to avoid freeze-ups.
3. Where rock is encountered, carry excavation 6" below required elevation and backfill with a 6" layer of crushed stone or gravel prior to installation of pipe.
4. Grade bottoms of trenches as indicated, notching under pipe bells to provide solid bearing for entire body of pipe.
5. Backfill trenches with concrete where trench excavations pass within 18" of column or wall footings and which are carried below bottom of such footings, or which pass under wall footings. Place concrete to level of bottom of adjacent footing.
6. Do not backfill trenches until inspections have been made and backfilling authorized by Architect. Use care in backfilling to avoid damage or displacement of pipe systems.

K. Cold Weather Protection:

1. Protect excavation bottoms against freezing when atmospheric temperature is less than 35°F. (1°C).

PART 4 - COMPACTION/CRITERIA

4.1 GENERAL

- A. Control soil compaction during construction providing minimum percentage of density specified for each area classification, at a depth of 12" below compaction surface.
- B. Compaction near the existing building shall be closely monitored and conducted with light equipment. Contractor shall coordinate a timetable for compaction with the building occupants as directed by the Office of Facilities Planning.
- C. Percentage of Maximum Density Requirements:
 1. Compact upper 12: subgrade soil to not less than the following percentages of maximum dry density as determined by the Modified Proctor Test (ASTM D-1557).

Below Foundation and Slab Bearing Elevation: 98%
Backfill Against Retaining Walls and in Trenches: 95%
- D. Moisture Control:
 1. Where subgrade or layer of soil material must be moisture conditioned before compaction, uniformly apply water to surface of subgrade, or layer of soil material, to prevent free water appearing on surface during or subsequent to compaction operations.
 2. Remove and replace, or scarify and air dry, soil material that is too wet to permit compaction to specified density.
 - a. Soil material that has been removed because it is too wet to permit compaction may be stockpiled or spread and allowed to dry. Assist drying by disking, harrowing or pulverizing until moisture content is reduced to a satisfactory value.
 3. Place fill and backfill material within 2% + deviation from optimum ASTM D-1557 moisture content.

4.2 PREPARATION

- A. Stripping:
 1. Remove all topsoil, organic materials, roots, debris, or other deleterious materials from building area and to 6' beyond building lines.
- B. Proofrolling within 15 feet of existing structure:
 1. Once excavations have been carried to bearing elevations of new foundations, compact soil with a walk-behind lightweight vibratory compactor. Conduct at least 15 full coverages, and continue compacting until above specified compaction criteria has been met.

- C. Proofrolling outside of the 15 foot limit:
 - 1. Compact soil with a vibratory roller having a weight of 8 to 10 tons. Conduct at least 10 full coverages, and continue compacting until the above specified compaction criteria has been met.

4.3 FILLING AND BACKFILLING

- A. General Filling and Backfilling:
 - 1. Place fill and backfill in layers not to exceed 6" for the small compactor and 12" for the large compactor in height loose measure and compact with same type of vibratory compactors described above.
 - 2. Excess fill may be disposed of on property if directed by Owner.
- B. Filling and Backfilling with Lightweight Compactors:
 - 1. When placing fill or backfill near or around trenches, foundations retaining walls, or other confined or limited access areas, use a lightweight hand-guided compactor. Place fill in layers not to exceed 4" in height loose measure.
 - 2. When placing fill or backfill 15 feet of existing structure, compact with same type of compactor specified for proofrolling.
- C. Densifying:
 - 1. Compact each layer individually until it has reached density level specified under "Compaction" above.

4.4 FIELD QUALITY CONTROL

- A. Quality Control Testing During Construction:
 - 1. Allow testing service to inspect and approve subgrades and fill layers before further construction work is performed.
 - 2. Conduct one density test for each 50 LF of continuous or wall footing and one per 2500 SF of slab or mat with a minimum of one per building side for the proofrolling level and subsequently for each layer of fill being placed.

4.5 MAINTENANCE

- A. Protection of Graded Areas:
 - 1. Protect newly graded areas from traffic and erosion. Keep free of trash and debris.
 - 2. Repair and re-establish grades in settled, eroded, and rutted areas to specified tolerances.

B. Reconditioning Compacted Areas:

1. Where completed compacted areas are disturbed by subsequent construction operations or adverse weather, scarify surface, reshape, and compact to required density prior to further construction.

4.6 DISPOSAL OF EXCESS AND WASTE MATERIALS

A. Removal from Owner's Property:

1. Remove waste materials, including unacceptable excavated material, trash and debris, and dispose of it off Owner's property.

END OF SECTION

SECTION 31 20 01
LIMEROCK BASE

PART 1 - GENERAL

1.1 WORK INCLUDED

- A. The work specified in this Section consists of the construction of a base course composed of limerock. It shall be constructed upon the prepared subgrade in accordance with these specifications and in conformity with the lines, grades, notes and typical cross section shown on the Drawings.

1.1 QUALITY ASSURANCE

- A. Laboratory analysis shall be complete, and the material accepted by the Engineer prior to placement.
- B. All work to be in compliance with Florida DOT "Standard Specifications for Road and Bridge Construction", latest edition, and geotechnical engineer's report recommendations.
- C. Construction manager to employ and pay for a qualified independent geotechnical testing and inspection laboratory to perform testing and inspection services during operations.

PART 2 - PRODUCTS

2.1 MATERIALS

- A. Source: The material used in limerock base courses shall be material classified as either Miami Oolite Formation or Ocala Formation at the Contractor's option; however, only one formation may be used on any contract.
- B. Composition:
 - 1. The limerock material shall contain not more than 0.5 percent of organic material or objectionable matter and shall show no significant tendency to air slake or undergo any chemical change under exposure to weather.
 - 2. Limerock material shall contain not less than 70 percent of carbonates of calcium and magnesium. The maximum percentage of water sensitive clay material shall be 3.
- C. Gradation:
 - 1. At least 97 percent (by weight) of the material shall pass a 3-1/2 inch sieve and the material shall be graded uniformly down to dust. The fine material shall consist entirely of dust of fracture. All crushing or breaking up which might be necessary in order to meet such size requirements shall be done before the material is placed on the road.
- D. Quality:
 - 1. The limerock material shall be uniform in quality and shall not contain cherty or other extremely hard pieces or lumps or pockets of sand or clay size material in sufficient quantity as to be detrimental to prevent proper bonding, finishing or strength of the limerock base. Limerock material shall be nonplastic, and the liquid limit shall not exceed 35.

2. Limerock material shall have an average LBR value of not less than 100.

3.1 GENERAL

A. Equipment:

1. All equipment necessary for the proper construction of the work shall be on the project, in first-class working condition, and shall have been approved by the Engineer prior to its use.

B. Limits of Construction:

1. The Construction manager shall construct the base to the full width shown on the Drawings.

3.2 PERFORMANCE

A. Transporting Limerock:

1. The limerock shall be transported to the point where it is to be used, over rock previously placed if practicable, and dumped on the end of the preceding spread. No hauling over the subgrade or dumping on the subgrade shall be done.

B. Spreading Limerock:

1. The limerock shall be spread uniformly, and all segregated areas of fine or coarse rock shall be removed and replaced with well-graded rock.
2. When the specified compacted thickness of the base is greater than 6 inches, the base shall be constructed in two courses. The thickness of the first course shall be approximately one-half the total thickness of the finished base, or enough additional to bear the weight of the construction equipment without disturbing the subgrade. At no time shall three (3) days work of the first course be spread and compacted ahead of the second course except where specifically directed by the Engineer.

C. Compacting and Finishing Base:

1. General:
 - a. For single course base, after spreading is completed, the entire surface shall be scarified and then shaped so as to produce the required grade and cross-section after compaction.
 - b. For double course base, the first course shall be cleaned of foreign material, bladed and brought to a surface cross section approximately parallel to that of the finished base. Prior to the spreading of any material for the upper course, the density tests for the lower course shall be made and the Engineer shall have determined that the required compaction has been obtained. After the spreading of material for the second course is completed, its surface shall be finished and shaped so as to produce the required grade and cross-section after compaction and free of scabs and laminations.

2. Moisture Content:
 - a. When the material does not have the proper moisture content to insure the required density, wetting or drying will be required. If the material is deficient in moisture, water shall be added and uniformly mixed in by dicing the base course to its full depth. If the material contains an excess of moisture, such excess shall be reduced or removed until the required moisture content is attained before being compacted. Wetting or drying operations shall involve manipulation of the entire width and depth of the base as a unit.
 3. Density Requirements:
 - a. As soon as proper conditions of moisture are attained, the material shall be compacted to a density of not less than 98 percent of the maximum density as determined by AASHTO Designation T 180.
 4. Density Tests:
 - a. During final compacting operations, if blading of any areas is necessary to obtain the true grade and cross section, the compacting operations for such areas shall be completed prior to making the density determinations on the finished base.
 - b. At least three density determinations shall be made on each day's final operations on each course, and the density determinations shall be made at more frequent intervals if deemed necessary by the Engineer.
 5. Correction of Defects:
 - a. If at any time the subgrade material should become mixed with the base course material, the Construction manager shall dig out and remove the mixture, reshape and compact the subgrade and replace the materials removed with clean base material, which shall be shaped and compacted as specified above.
 - b. If cracks or checks appear in the base, either before or after priming, which in the opinion of the Engineer would impair the structural efficiency of the base course, the Construction manager shall remove such cracks or checks by rescarifying, reshaping, adding base material where necessary and recompacting.
- D. Testing Surface:
1. The finished surface of the base course shall be checked with a templet cut to required crown and cross-section and with a 10-foot straightedge laid parallel to the centerline of the road. All irregularities greater than 1/4-inch shall be corrected by scarifying and removing or adding limerock as may be required, after which the entire area shall be recompacted as specified hereinbefore.

E. Thickness Determinations:

1. The thickness of the compacted limerock base shall be measured at intervals of not more than 200-feet. Measurements shall be taken at various points on the cross- sections prior to the application of the prime coat.
2. The measurements shall be taken in holes through the base of not less than 3-inches in diameter. Where the compacted base is deficient by more than 1/2-inch from the thickness called for on the Drawings, the Construction manager shall correct such areas by scarifying and adding limerock. The base shall be scarified and rock added for a distance of 100-feet in each direction from the edge of the deficient area. The affected areas shall then be brought to the required state of compaction and to the required thickness and cross-section.

F. Priming and Maintaining:

1. The prime coat shall be applied only when the base meets the specified density requirements and the moisture content in the top half of the base does not exceed 90 percent of the optimum moisture content of the base material. At the time of priming, the base shall be firm and unyielding.
2. The Construction manager will be responsible for assuring that the true crown and grade are maintained with no rutting or other distortion and that the base meets all the requirements at the time the surface course is applied. Care shall be taken to remove all loose dust, dirt and objectionable matter. If deemed necessary, the base shall be slightly sprinkled with water in advance of the prime coat.
3. The temperature of the prime material shall be such as to insure uniform distribution. The material shall be applied with a pressure distributor. The amount to be applied shall be sufficient to coat the surface thoroughly and uniformly without any excess to form pools or to flow off the base. The base shall be primed by the application of approximately 0.15 gallons per square yard of RC-70 meeting the requirements of Section 914-2 of the Standard Specification, Asphalt Emulsion Prime (AEP) meeting the requirements of Section 916-4 of the Standard Specifications, or other materials approved by the Engineer. Cutback asphalt shall conform to the requirements of AASHTO Designation M 81.
4. Following the application of the prime material, a light uniform application of clean sand shall be applied and rolled with a traffic roller, for the full width of the base. The sand shall be non-plastic, shall be free from silt and rock particles and shall not contain any sticks, vegetation, grass, roots or organic matter. After the sand covering has been applied and rolled, the surface may be opened to traffic.

END OF SECTION

SECTION 31 20 02
ASPHALTIC CONCRETE SURFACE COURSE

PART 1 - GENERAL

1.1 WORK INCLUDED

- A The work included in this section consists of the construction of an asphaltic concrete level course and surface course composed of a mixture of aggregates, mineral filler and asphalt cement properly laid upon a prepared base, or a newly constructed level course, in accordance with these specifications and in conformity with the lines, grades, thickness and typical cross section shown on the Drawings. Unless otherwise indicated on the Drawing, the Contractor shall furnish Type III and Type S-1 asphaltic concrete.

1.2 QUALITY ASSURANCE

- A. Laboratory analysis by a Certified Testing Laboratory on all materials shall be completed and the materials accepted by the Engineer prior to placement. Density Test shall be made every 1,000 feet or as directed by the Engineer and shall be at 95% or better.

PART 2 - PRODUCTS

2.1 MATERIALS

- A. Bituminous Material: Asphalt cement, Viscosity Grade AC-20, shall conform to the requirements of FDOT Standard Specifications, Edition of 2010, Section 916-1.
- B. Coarse Aggregate: The course aggregate shall be composed of clean, durable limerock. When subjected to the Los Angeles Abrasion Test, (AASHTO T 96), the loss shall not exceed 45 percent.
- C. Extraneous Substances: All coarse aggregates shall be washed and free from disintegrated pieces, salt, alkali, vegetable matter and adherent coating.
 - 1. The weight of the extraneous substances shall not exceed the following percentage.

	<u>Percent</u>
Coal and Lignite	1.00
Clay Lumps	0.05
Cinders and Clinkers	0.05
Soft Fragments	10.00
Free Shells	1.00
Sticks (Wet)	0.03
Material Passing No. 200 Valve	1.75

- D. In addition, the sum of the percentage of all materials listed above shall not exceed 10 percent. Coarse aggregate containing any appreciable amount of phosphate shall not be used.

- E. Stone: Pre-Cenozoic limestones and dolomites shall not be used as crushed-stone aggregates, either coarse or fine, for wearing courses of asphaltic concrete surface courses. This specifically includes materials from the Ketona Dolomite (Cambrian), Newala Limestone (Lower Ordovician), Bangor Limestone (Mississippian), and other informations of similar composition and origin occurring in central and Northern Alabama and Georgia.
 - 1. Slag: Slag shall be clean, tough and durable. It may be either air-cooled blast-furnace slag or phosphate slag. It shall be reasonably uniform in density and quality, and free from deleterious substances other than as permitted above. It shall contain no more than 1.5 percent of sulphur. The dry-rodded weight shall be not less than 70 pounds per cubic foot. The loss, when the slag is subjected to the Los Angeles Abrasion Test, shall not exceed 45 percent.

F. Fine Aggregate:

- 1. Fine aggregate shall consist of natural sand, stone screenings, slag screenings or a combination thereof, composed of lean, tough, angular grains, free from clay, loam or other foreign matter. Stone or slag screenings shall be produced from materials complying with the abrasion requirements for coarse aggregate specified above.
- 2. Any screenings used in the combination of aggregate shall contain not more than 15 percent of material passing the No. 100 sieve and shall be washed if necessary to meet this requirement.
- 3. The natural sand portion of the fine aggregate other than screening shall be siliceous containing not more than 10 percent of material passing the No. 200 sieve.
- 4. This fine aggregate, when tested by means of laboratory sieves, shall meet the following requirements:

<u>Passing Sieve</u>	<u>Retained on Sieve</u>	<u>Percent by Weight</u>
No. 4		90 - 100
No. 4	No. 10	0 - 15
No. 10	No. 40	15 - 50
No. 40	No. 80	25 - 60
No. 80	No. 200	8 - 40
No. 200		0 - 10
- 5. Fine aggregate containing more than 1.00 percent of phosphate shall not be used.

G. Mineral Filler:

- 1. Mineral filler shall consist of limerock dust, Portland cement slag dust, hydrated lime or other inert mineral matter approved by the Engineer and conforming to the following gradation requirements:
 - Total Passing No. 30 Sieve.....100 percent
 - Total Passing No. 80 Sieve..... 95 percent (Min.)

Total Passing No. 200 Sieve..... 65 percent (Min.)

2. The mineral filler shall be thoroughly dry and free from lumps consisting of aggregations of fine particles. Ground phosphate will not be allowed as a mineral filler.

2.2 GENERAL COMPOSITION OF MIXTURE

- A. The bituminous mixture shall be composed of a combination of aggregate (coarse, fine or mixtures thereof), mineral filler, if required, and bituminous material. The several aggregate fractions shall be sized, uniformly graded and combined in such proportions that the resulting mixture will meet the grading and physical properties of the approved job mix formula.
- B. In all cases, the job mix formula shall be within the design ranges specified in the following table:

GRADATION DESIGN RANGE

<u>Sieve Size</u>	<u>Type III</u>	<u>Percent by Weight Passing Type S-1</u>
3/4-inch		100
1/2-inch	100	80-100
3/8-inch	80-100	75-93
No. 4	65-100	47-75
No. 10	40-75	31-53
No. 40	20-45	19-35
No. 80	10-30	7-21
No. 200	2-10	2-6

- C. Asphalt cement (Bitumen) shall consist of 4 1/2 to 9 percent by weight of the total mix as determined by job mix formula. For highly absorptive aggregates, the upper limit may be raised.

2.3 FORMULA FOR JOB MIX

- A. The general composition limits prescribed above are master ranges of tolerances to govern mixtures made from any materials meeting the specification, and they are maximum and minimum for all cases. A close control appropriate to the job materials, will be required for the specific project in accordance with the job mix formulas.
- B. No work shall be started on the specific project until the Engineer has approved the job mix formula.
- C. Materials that will be used to make up the approved job mix should be stockpiled in sufficient quantity to meet the demands for the entire project in progress. If this is not practicable, care must be taken to insure adequate quality control of the materials used in each job mix. Should the source of supply for the materials used in the job mix be changed, or should the materials from the source vary appreciably from the materials used in the job mix formula, the job mix formula must be altered accordingly.
- D. Combined dry aggregate gradation of the hot bins shall be within the limits of the job formula.

- E. After the job mix formula is established, each mix for the project shall meet the approved formula within the following tolerances:

<u>Characteristics</u>	<u>Tolerances</u>
Asphalt Content (Extraction)	±0.70%
Asphalt Content (Printout)	±0.30%
Passing No. 10 Sieve	±6.50%
Passing No. 200 Sieve	±3.00%

- F. In no case shall a job mix that is within the tolerances stated above be such that it falls out of the master range.
- G. Gradation extraction test samples of the mixture in use will be taken twice daily, once in the morning and once in the afternoon and as is necessary in the opinion of the Engineer. The mixtures shall be maintained uniformly throughout the project within the use of such additional bituminous material content.
- H. Job materials found to have characteristics requiring a content of bituminous material less than is indicated in the formula prescribed above, will be rejected or adjusted to form a blend which will produce a balanced mixture under the terms of the formula. Where job materials otherwise meeting specifications are found, on account of highly absorptive or other special characteristics, to produce an acceptable balance mix only if the bituminous material content is increased over the amount specified, the mixture may be accepted provided that the job mix shall be adjusted to require the use of such additional bituminous material content.
- I. The asphaltic content shall be such for the material used that when the mixture is tested, in accordance with ASTM Designation D 1559, the stability shall be at a maximum with an optimum asphalt cement content. Physical properties of the mix shall be as shown on the following table:

<u>Mix Type</u>	<u>Minimum</u>		<u>Minimum VMA (%)</u>	<u>Minimum</u>	
	<u>Marshall Stability (lbs)</u>	<u>Flow (0.01 in)</u>		<u>Air Voids (%)</u>	<u>Effective Asphalt Content</u>
S-1	1000	8 - 14	14	3-5	5.0
Type III	1000	8 -16	15	5-12	5.5

PART 3 – EXECUTION

3.1 PREPARATION OF ASPHALTIC CEMENT

- A. The asphalt cement shall be delivered to the mixture at a temperature not to exceed 360°F and shall be maintained within a range of 230°F to 350°F in advance of mixing operations. Heating within these limits shall be constant and wide fluctuations of temperature during a day's production will not be permitted.

3.2 PREPARATION OF AGGREGATES

- A. Stockpiling coarse aggregate shall be done in such a manner so the aggregate will not segregate.
- B. All aggregates to be blended or proportioned shall be placed in separate bins at the cold hopper and proportioned by means of calibrated gates or other approved devices. When two or more aggregates are blended, the use of two or more bins shall be employed for the blending of such material.
- C. The aggregates shall be heated and dried at the paving plant before entering the mixer. The temperature of the aggregates shall be so controlled that the temperature of the completed mixture at the plant will fall within the permissible range allowed by these Specifications. Any dried aggregate contaminated with fuel oil shall be wasted.

3.3 PREPARATION OF MIXTURE

- A. Batch Mixing
 - 1. The dried aggregate, prepared as hereinbefore and combined in batches to meet the job mix formula by weighing each separate bin size, shall be conveyed to the empty mixer.
 - 2. The hot asphalt cement, accurately measured, shall then be introduced, and the mixing continued until the mixture is thoroughly uniform and homogeneous. The total mixing time in no case shall be less than 35 seconds.
- B. Continuous Mixing: The dried shall be heated and combined in such a manner as to produce a mixture which shall be at a temperature, when discharged from the pugmill or surge bin hot asphalt cement shall be introduced into the mixer in synchronization with the feeding of aggregate. The quantity shall be measured by volume. Mixing shall be sufficient to produce a thoroughly uniform and homogeneous mixture.
- C. General: The ingredients of the mix shall be heated and combined in such a manner as to produce a mixture which shall be at a temperature, when discharged from the pug-mill or surge bin, between the limits of 230°F and 310°F, and within 25° of the temperature set by the Engineer.

3.4 TRANSPORTATION OF MIXER

- A. The mixture shall be transported in tight vehicles previously cleaned of all foreign material and, if necessary, each load shall be covered with a waterproof canvas cover of sufficient dimensions to protect it from weather conditions. The inside surface of the truck bodies may be thinly coated with soapy water, or a mixture of water with not more than five percent of lubricating oil, but no excess of either should be used. After the truck bodies are coated and before any mixture is placed therein, they shall be raised so that all excess water will drain out. Kerosene, gasoline or similar products shall not be used to prevent adhesion.

3.5 LIMITATIONS FOR SPREADING

- A. The mixture shall be spread only when the surface is properly prepared and is intact, firm, cured and dry. No mixture shall be spread when the air temperature is less than 40°F, nor when the spreading cannot be finished and compacted during daylight hours. The temperature of the mix at the time of spreading shall not be less than 230°F and within 25°F of the temperature set by the Engineer.

3.6 PLACING MIXTURE

- A. Upon arrival, the mixture shall be dumped into the approved mechanical spreader and immediately spread and struck off to the full width required and to such appropriate loose depth for each successive course that
- B. When the work is completed the required thickness or weight of mixture per square yard will be secured. An excess amount of mixture shall be carried ahead of the screed at all times. Hand raking shall be done behind the machine as required.
- C. In limited areas, where, on account of irregularities or unavoidable obstacles, the use of mechanical spreading and finishing equipment is impracticable, the mixture may be spread by hand, when so authorized by the Engineer.
- D. The mixture shall be laid only when the surface to be covered is dry and only when weather conditions are suitable. All defective areas in the foundation shall be replaced as directed at least ten days in advance of laying the mixture.
- E. All structures which will be in actual contact with the asphaltic mixture, including the vertical faces of existing payments, shall be painted with a uniform coating of asphalt material to provide a closely bonded, watertight joint. Asphaltic mixture to be as described by F.D.O.T. specification 300-6 and 300-7.
- F. When necessary, due to the traffic requirements, the mixture shall be laid in strips in such manner as to provide for the passage of traffic. When the road is closed to traffic, the mixture may be laid the full width of pavement, by machines traveling in echelon.
- G. Before any rolling is started, the surface shall be checked, any inequalities adjusted, and all drippings, fat sandy accumulations from the screed, and fat spots from any source shall be removed and replaced with satisfactory material.

3.7 COMPACTING MIXTURE

- A. After the spreading, the mixture shall be rolled when it has set sufficiently or come to the proper condition to be rolled, and when the rolling does not cause undue displacement or shoving.
- B. Rolling shall begin at the center and progress toward the outside, paralleling the centerline of the roadway, uniformly lapping at least one-half of the width of the roller.
- C. The motion of the roller shall at all times be slow enough to avoid displacement of the mixture, and any displacement shall at once be corrected by the use of rakes and fresh mixture where required. The rolling shall include transverse, longitudinal, diagonal and, where practical, crescent rolling, as may be necessary to obtain the specified density.
- D. The seal rolling with steel wheel rollers weighing from 5 tons to 12 tons shall follow as close behind the spreader as is possible without picking up, displacing, or blistering the material. Rolling with the self-propelled pneumatic-tired rollers shall follow as soon as possible and as close behind the seal rolling as the heat of the mixture will permit. This rolling shall be done such that the self-propelled traffic roller shall cover every area of the surface with at least six passes. This final rolling shall be done before the pavement temperature is lower than 140°F, and shall be used for the rolling of patching and leveling courses. At the option of the Contractor, a steel wheeled roller may be used to supplement the self-propelled pneumatic-tired rollers, but not more than one steel wheeled roller may be used in conjunction with the necessary number of self-propelled

pneumatic-tired rollers. After final compaction, the finished pavement shall at no point have a density less than 95 percent of the laboratory compacted density. Rolling with the self propelled pneumatic-tired roller shall proceed at a speed from 6 to 10 miles per hour and the rate of rolling shall not exceed 3,000 square yards per hour per roller. A sufficient number of self-propelled pneumatic-tired rollers shall be used so that the rolling of the surface for the required number of passes within this maximum rolling rate shall not delay mixture before the rolling is complete. In the event that the rolling is not properly maintained to schedule as outlined above, the laying operation shall be discontinued until the rolling operations have caught up to the spreader(s).

- E. In all places inaccessible to a roller, such as adjacent to curbs, headers, gutters, bridges, manholes, etc., the required compaction shall be secured with tamps. Depressions which may develop before the completion of the rolling shall be remedied by loosening the mixture laid and adding new material to bring such depressions to a true surface.
- F. Gasoline or oil from rollers shall not be allowed to deposit on the pavement and any pavement damaged by such deposits shall be removed and replaced.
- G. Any mixture remaining unbonded after rolling shall be removed and replaced.

3.8 JOINTS

- A. **Transverse Joints:** At the end of each day's work, or whenever the laying is to be discontinued for such length of time as to allow the mixture to become chilled, transverse joints shall be formed either by laying a board, equal in thickness to the compacted thickness of the pavement, across the width of strip being spread and rolling the mixture against the board, or by using paper or sand, provided in either case the asphalt is cut back to well bonded material of the required thickness before placing additional asphalt.
- B. **Longitudinal Joints:** Where only a portion of the width of pavement is to be laid and opened to traffic, longitudinal joints shall be formed by rolling the exposed edge of the strip first laid. When the adjacent strip is constructed, the edge of the mixture in place shall be trimmed back so as to expose an unsealed or granular vertical surface.
- C. When the strip first laid is closed to traffic, the edge shall not be sealed, but shall be left vertical and the adjacent strip placed against it without trimming.
- D. **General:** The exposed edge of the transverse joints, trimmed or formed as provided above, shall be painted with a thin coat of hot asphalt cement just prior to the laying of fresh surface course mixture adjacent. The fresh mixture shall be raked against the joint and rolled.

3.9 FIELD QUALITY CONTROL

- A. **Surface Requirements:**
 - 1. For the purpose of testing the finished surface, a 10-foot straightedge and a standard template cut to the true cross section of the road shall at all times be available on the work. The Contractor shall provide or designate some employee whose duty it is to handle the straightedge and template in checking all rolled surfaces. Test shall be performed by independant testing lab on the density asphalt to determine that it meets density requirements. Such test shall be made at the direction of Engineer.
 - 2. The finished surface shall be such that it will not vary more than 1/4-inch from the template cut to the cross section of the road, no more than 3/16-inch from the 10-foot straightedge applied parallel to the centerline of the pavement. Any

irregularity of the surface exceeding the above limits shall be corrected. Depressions which may develop after the initial rolling shall be remedied by loosening or removing the mixture and adding new material to bring the areas to a true surface. No skin patching shall be done. Such portions of the completed pavement as are defective in surface compaction or in composition, or that do not comply with all other requirements of these specifications, shall be taken up and replaced with suitable mixture properly laid in accordance with these specifications and at the expense of the Contractor.

- B. Thickness Requirements: The thickness of the compacted asphaltic concrete surface course shall be no less than that shown on the Drawing as determined by coring. Any surface course found to be less than thickness shall be removed and replaced.
- C. Protection of Pavement: After the completion of the pavement, no vehicular traffic of any kind shall be permitted on the pavement until it has set sufficient to prevent rutting or other distortion.

END OF SECTION

SECTION 31 20 03
DEWATERING

PART 1 - GENERAL

1.1 DESCRIPTION

- A. Scope of Work: The work to be performed under this section shall include furnishing all equipment and labor necessary to remove storm or subsurface waters from excavation areas in accordance with the requirements set forth and as shown on the Drawings.
- B. Dewatering may be required during new pipe placement, installation of access pits, excavation, and any other areas deemed necessary by the Owner.
- C. Related Work Described Elsewhere:
 - 1. Section 311100 - Earthwork.

1.2 QUALITY ASSURANCE

- D. The dewatering of any excavation areas and the disposal of the water shall be in strict accordance with the latest revision of all local and State government rules and regulations.

PART 2 - PRODUCTS (NOT USED)

PART 3 - EXECUTION

1.3 DEWATERING

- A. The Contractor shall provide adequate equipment for the removal of storm or subsurface waters which may accumulate in the excavation.
- B. The Contractor shall obtain all necessary permits prior to dewatering.
- C. If subsurface water is encountered, the Contractor shall utilize suitable equipment to adequately dewater the excavation so that it will be dry for work and pipe laying. A wellpoint system or other Engineer approved dewatering method shall be utilized if necessary to maintain the excavation in a dry condition for preparation of the trench bottom and for pipe laying.
- D. Dewatering by trench pumping will not be permitted if migration of fine-grained natural material from bottom, side walls, or bedding material will occur.
- E. In the event that satisfactory dewatering cannot be accomplished due to subsurface conditions or where dewatering could damage existing structures, the Contractor shall obtain the Engineer's approval of wet trench construction or procedure before commencing construction.
- F. As part of the noise control, the dewater pump(s) shall have a noise emission not to exceed 70 dBA at 50'.

1.4 DISPOSAL

- G. Water pumped from the trench or other excavation shall be disposed of in on site storm sewers having adequate capacity, or suitable disposal pits.
- H. Contractor is responsible for acquiring all permits required to discharge the water and shall protect waterways from turbidity during the operation.
- I. In areas where adequate disposal sites are not available, partially backfilled trenches may be used for water disposal only when the Contractor's plan for trench disposal is approved in writing by the Engineer. The Contractor's plan shall include temporary culverts, barricades and other protective measures to prevent damage to property or injury to any person or persons.
- J. No flooding of streets, roadways, driveways or public right-of-way will be permitted.
- K. Engines driving dewatering pumps shall be equipped with residential type mufflers.

END OF SECTION

SECTION 31 20 05
SUBGRADE STABILIZATION

PART 1 - GENERAL

1.1 WORK INCLUDED

- A. The work specified in this Section consists of the construction of a stabilized roadway subgrade where indicated on the Drawings. Construction shall be to the uniformity, density and bearing ratio specified hereinafter. Roadways and streets shall be stabilized to the depths and dimensions indicated on the Drawings.
- B. Definitions: The stabilizing shall be FDOT Type B as described hereinafter. The required bearing ratio value shall be obtained either by construction of the subgrade of selected materials from the roadway and borrow area(s), or by stabilizing the subgrade material by the addition and mixing in of suitable stabilizing material. Such work shall be done in accordance with these specifications, lines, grades, thickness and notes shown on the Drawings.

PART 2 - GENERAL

2.1 MATERIALS

- A. General:
 - 1. The particular type of stabilizing material to be used shall be in accordance with Paragraph 2.1 E. hereinafter and shall meet the following requirements.
- B. Use of Materials From Existing Base:
 - 1. When the utilization of materials from an existing base is called for, (as all, or a portion, of the stabilizing additives) the Owner will direct the locations, placing and distribution of such materials, and this work shall be done prior to the spreading of any additional commercial or local materials. Removal of any section of existing base will not be required until the need for it in maintaining traffic is fulfilled.
 - 2. The utilization of materials from an existing base may be called for in combination with the designated type of stabilizing.
- C. Commercial Materials:
 - 1. General: Materials which are designated as Commercial Materials which are to be used for this stabilizing may be either commercial limerock, limerock overburden or crushed shell.
 - 2. Limerock: Specific requirements for limerock and limerock overburden: For limerock and limerock overburden, the percentage of carbonates of calcium and magnesium shall be at least 70, and the plasticity index shall not exceed 10. The gradation of both commercial limerock and limerock overburden shall be such that 97 percent of these materials will pass a 1-1/2" sieve.
 - 3. Crushed Shell: Crushed shell for this use shall be mollusk shell (i.e., oysters, mussels, clams, cemented coquina, etc.). Steamed shell will not be permitted. This shell shall meet the following requirements:

- a. At least 97 percent by weight of the total material shall pass a 1 inch screen and at least 50 percent by weight of the total material shall be retained on the No. 4 sieve.
- b. Not more than 7.5 percent by weight of the total material shall pass the No. 200 sieve. The determination of the percentage passing the No. 200 sieve shall be made by washing the material over the sieve.
- c. In the event that the shell meets the above requirements without crushing, crushing will not be required.

D. Local Material:

1. General: Local materials used for this stabilizing may be high bearing-value soils or sand-clay material. The material passing the 40-mesh sieve shall have a liquid limit not greater than 30 and a plasticity index not greater than 10.
2. Blending: No blending of materials to meet these requirements will be permitted unless authorized by the Owner. When blending is permitted, the blended material shall be tested and approved before being spread on the roadway.

E. Type B Stabilization:

1. The type of materials, Commercial or Local, shall be at the Contractor's option.
2. No separate payment for stabilizing materials will be made.
3. Bearing Value determinations will be made by the Limerock Bearing Ratio Method.
4. Under this method, it shall be the Engineer's responsibility that the finished roadbed section meets the bearing value requirements, regardless of the quantity of stabilizing materials necessary to be added. Also under this method, full payment will be made for any areas where the existing sub-grade materials meet the design bearing value requirements without the addition of stabilizing additives, as well as areas where the Owner may elect to place select high-bearing materials from other sources, within the limits of the stabilizing.
5. After the roadbed grading operations have been substantially completed, the Civil Engineer shall make his own determination as to the quantity (if any) of stabilizing material, of the type selected by him, necessary for compliance with the bearing value requirements. The Contractor shall notify the Owner of the approximate quantity to be added, and the spreading and mixing in of such quantity of materials shall meet the approval of the Owner as to uniformity and effectiveness.

PART 3 - EXECUTION

3.1 PREPARATION

A. General:

1. Prior to the beginning of stabilizing operations, the area to be stabilized shall have been constructed to an elevation such that upon completion of stabilizing operations the completed stabilized subgrade will conform to the lines, grades and cross section shown in the plans. Prior to the spreading of any additive

stabilizing material, the surface of the roadbed shall be brought approximately parallel to the plane of the proposed finished surface.

2. The subgrade to be stabilized may be processed in one course, unless the equipment and methods being used do not provide the required uniformity, particle size limitation, compaction and other desired results, in which case, the Owner will direct that the processing be done in more than one course.

3.2 APPLICATION

A. Stabilizing Material:

1. When additive stabilizing materials are required, the designated quantity shall be spread uniformly over the area to be stabilized.
2. When materials from an existing base are to be utilized in the stabilizing at a particular location, all of such materials shall be placed and spread prior to the addition of other stabilizing additives.
3. Commercial stabilizing material shall be spread by the use of mechanical material spreaders except that where use of such equipment is not practicable other means of spreading may be used, but only upon written approval of the proposed alternate method.

B. Mixing:

1. The mixing shall be done with rotary tillers, or other equipment meeting the approval of the Owner. The area to be stabilized shall be thoroughly mixed throughout the entire depth and width of the stabilizing limits.
2. The mixing operations, as specified, will be required regardless of whether the existing soil, or any select soils placed within the limits of the stabilized sections, have the required bearing value without the addition of stabilizing materials.
3. As an exception to the above mixing requirements, where the subgrade is of rock, the Owner may direct that the mixing operations (and the work of stabilizing) be waived and no payment for stabilization will be made for such sections of the roadway.

C. Maximum Particle Size of Mixed Materials: At the completion of mixing, all particles of material within the limits of the area to be stabilized shall pass a 3 1/2 inch ring. Any particles not meeting this requirement shall be removed from the stabilized area or shall be broken down so as to meet this requirement.

D. Compaction: After the mixing operations have been completed and requirements for bearing value, uniformity and particle size have been satisfied, the stabilized area shall be compacted, in accordance with Paragraph 3.3 B. hereinafter. The materials shall be compacted at a moisture content permitting the specified compaction. If the moisture content of the material is improper for attaining the specified density, either water shall be added or the material shall be permitted to dry until the proper moisture content for the specified compaction is reached.

E. Finish Grading: The completed stabilized subgrade shall be shaped to conform with the

finished lines, grades and cross-section indicated in the Drawings. The subgrade shall be checked by the use of elevation stakes, or other means approved by the Owner.

F. Requirements for Condition of Completed Subgrade:

1. After the stabilizing and compacting operations have been completed, the subgrade shall be firm and substantially unyielding, to the extent that it will support construction equipment and will have the bearing value required by the Drawings.
2. All soft and yielding material, and any other portions of the subgrade which will not compact readily, shall be removed and replaced with suitable material and the whole subgrade brought to line and grade, with proper allowance for subsequent compaction.

G. Maintenance of Completed Subgrade: After the subgrade has been completed as specified above, the Contractor shall maintain it free from ruts, depressions and any damage resulting from the hauling or handling of materials, equipment, tools, etc. It shall be the Contractor's responsibility to maintain the required density until the subsequent base of pavement is in place. Such responsibility shall include any repairs, replacement, etc., of curb and gutter, sidewalk, etc., which might become necessary in order to recompact the subgrade in the event of underwash or other damage occurring to the previously compacted subgrade. Any such work required for recompaction shall be at the Contractor's expense. Ditches and drains shall be constructed and maintained along the completed subgrade section.

3.3 FIELD QUALITY CONTROL

A. Bearing Value Requirements:

1. General: Bearing value samples will be obtained and tested by the Owner at completion of satisfactory mixing of the stabilized area. For any area where the bearing value obtained is deficient from the value indicated in the Drawings, in excess of the tolerances established herein, additional stabilizing with 3.1 B.1. and B.2. This reprocessing shall be done for the full width of the roadway being stabilized and longitudinally for a distance of 50 feet beyond the limits of the area in which the bearing value is deficient.
2. Tolerances In Bearing Value Requirements: The following undertolerances from the specified bearing value will be allowed as based on tests performed on samples obtained after mixing operations have been completed:

Specified Bearing	Value Undertolerances
LBR 40	5.0
LBR 35	4.0
LBR 30 (and under)	

B. General: Within the entire limits of the width and depth of the areas to be stabilized, the minimum density acceptable at any location will be 98 percent of the maximum density as determined by AASHTO T 180, Test Method D.

END OF SECTION

SECTION 31 20 10
STRUCTURAL EXCAVATION AND BACKFILL

PART 1 GENERAL

1.1 WORK INCLUDED

- A. The work included under this Section consists of excavating, backfilling and grading required for the construction of the structure(s) as shown on the Drawings and as specified herein.
- B. Definitions:
 - 1. Maximum Density: Maximum weight in pounds per cubic foot of a specific material.
 - 2. Optimum Moisture: Percentage of water in a specific material at maximum density.
 - 3. Rock Excavation: Excavation of any hard natural substance which requires the use of explosives and/or special impact tools such as jack hammers, sledges, chisels or similar devices specifically designed for use in cutting or breaking rock, but exclusive of trench excavating machinery.
- C. Plan for Excavating: The Contractor shall be responsible for having determined to his satisfaction, prior to the submission of his bid, the conformation of the ground, the character and quality of the substrata, the types and quantities of materials to be encountered, the nature of the groundwater conditions, the prosecution of the work, the general and local conditions and all other matters which can in any way affect the work under this Contract. Prior to commencing the excavation, the Contractor shall submit a plan of his proposed operations to the Civil Engineer for approval. The Contractor shall consider, and his plan for excavation shall reflect, the equipment and methods to be employed in the excavation. The prices established in the Proposal for the work to be done will reflect all costs pertaining to the work. No claims for extras based on substrata or groundwater table conditions will be allowed.

1.2 QUALITY ASSURANCE

- A. A Testing Laboratory retained by the Owner will make such tests as are deemed advisable. The Contractor shall schedule his work so as to permit a reasonable time for testing before placing succeeding lifts and shall keep the laboratory informed of his progress.

1.3 JOB CONDITIONS

- A. Test borings made on the site are available upon request as stated in the Special Conditions and are for the Contractor's information only.
- B. If, in the opinion of the Civil Engineer, conditions encountered during construction warrant a change in the footing elevation, or in the depth of removal of unsuitable material from that indicated on the Drawings, an adjustment will be made in the contract price.

PART 2 - PRODUCTS

2.1 MATERIALS

- A. Suitable: Suitable materials for backfill shall be classified as A-1, A-3 or A-2-4 in accordance with AASHTO Designation M-145 and shall be free from vegetation, organic material, marl, silt or muck. (Not more than 12 percent shall pass the No. 200 sieve.) (The Owner will provide borrow sites within the project limits for the additional fill material required, until all borrow sites are exhausted; thereafter, the Contractor shall provide the necessary material.) (The Contractor shall provide all necessary borrow material to complete the work to the lines and grades indicated.)
- B. Suitable Material to be Placed in Water: Suitable material for fills to be placed in water shall be classified as A-1 or A-3 in accordance with AASHTO Designation M-145.
- C. Unsuitable: Unsuitable materials are classified as A-2-5, A-2-6, A-2-7, A-4, A-5, A-6, A-7 and A-8 in accordance with AASHTO Designation M-145.
- D. Graded Limerock: Material for backfill below precast structures shall be 3/4-inch graded limerock equal to FDOT Section 901, Grade 6.
- E. Select Material: Select material shall be suitable material that does not contain any rock larger than will pass a 3-inch diameter ring.
- F. Pad Material: Material for the pad or embankment shall be a natural noncohesive, nonplastic material, a mixture of sand and rock containing sufficient sand to fill all voids between rocks and in the upper 12-inches containing no individual rock or hard piece large than 3-inches in major dimensions.
- G. Washed Rock: Washed rock for French drains shall be coarse aggregate for concrete with a minimum of fine material (FDOT Grade 3 or 4).

PART 3 - EXECUTION

3.1 PREPARATION

- A. Clearing:
 - 1. The construction site shall be cleared of all obstructions and vegetation, including large roots and undergrowth, within 10 feet of the lines of excavation.
 - 2. Strip and stockpile topsoil.
- B. Removals:
 - 1. Complete all removals within the lines of excavation prior to beginning excavation.

1 PERFORMANCE

A. Excavation:

1. The Contractor shall perform all excavation of every description and of whatever substances encountered, to the dimensions required for construction and as specified herein. All excavations shall be made by open cut.
2. Walls of the excavation shall be kept vertical and, if required to protect the safety of workmen, the general public, this or other work or structures, or excavation walls, the excavation shall be properly sheeted and braced. Excavation for the structures shall be sufficient to provide a clearance between their outer surfaces and the face of the excavation, sheeting, or bracing, of not less than 2-feet. Materials encountered in the excavation which have a tendency to slough or flow into the excavation, undermine the banks, weaken the overlying strata, or are otherwise rendered unstable by the excavation operation shall be retained by sheeting, stabilization, grouting or other approved methods. Excavation for precast or prefabricated structures will not be required to be dewatered.
3. Excavation for the precast or prefabricated structures shall be carried to an elevation 1-foot lower than the proposed outside bottom of the structure to provide space for the select backfill material. Prior to placing the select backfill, the excavation shall be sounded, if not dewatered, using a rigid pole to indicate to the satisfaction of the Civil Engineer that the excavation has been carried to the proper depth and is reasonably uniform over the area to be occupied by the structure.
4. Excavation for structures constructed or cast in place in dewatered excavations shall be carried down to the bottom of the structure where dewatering methods are such that a dry excavation bottom is exposed and the naturally occurring material at this elevation leveled and left ready to receive construction. Material disturbed below the founding elevation in dewatered excavations shall be replaced with Class B concrete.
5. Footings: Cast-in-place concrete footing sides shall be formed immediately after excavation. Forming for footing sides is specified elsewhere.

B. Dewatering (When Required): Any water which accumulates in the excavations for cast-in-place concrete structures shall be removed promptly by well point system or by other means satisfactory to the Civil Engineer in such a manner as to not create a nuisance to adjacent property or public thoroughfare. Pumps and engines for well point systems shall be operated with mufflers and at a minimum noise level suitable to a residential area. The Contractor shall be responsible for any nuisance created due to the disposal of water from his drainage system.

A. Stockpiled Materials: Materials removed from the excavation shall be stored and disposed of in a manner which will not interfere with traffic at the site. Material suitable for backfill not needed for backfill at the structure, but needed elsewhere shall be stockpiled until moved and used elsewhere. Material unsuitable for use in backfill shall become the property of the Contractor and shall be removed and disposed of by the Contractor at the Contractor's expense immediately after backfill is placed.

D. Backfill:

1. Below Precast or Prefabricated Structures: The space between the proposed outside bottom of the structure, and the bottom of the excavation shall be backfilled with graded limerock and screeded level to receive the proposed structure. If the excavation is not dewatered, after placing and screeding, the backfill will be sounded with a rigid pole and attached to a 6-inch diameter foot piece to indicate, to the satisfaction of the Civil Engineer, that the backfill has been placed to the proper elevation, is level throughout and is ready to receive the structure. This final sounding of the material shall immediately precede setting of the structure.
2. Remainder of Backfill: Selected material from the excavation shall be used for backfilling around the structure. Trash shall not be allowed to accumulate in spaces to be backfilled. Backfill around the structure shall be placed in uniform layers to the level of the water table. Above the water table, backfill material shall be placed in 8-inch layers and compacted to a minimum of 95 percent of maximum density as determined by AASHTO Designation T 180. Backfilling shall be carried to the finished grades shown on the Drawings.
3. Backfill for Structures Constructed or Cast-in-Place: Backfill shall not be placed until the structure has been completed above the natural water table, is stable against hydrostatic uplift, exterior form work has been removed and any necessary patching and grouting has been completed. Dewatering operations may then be stopped and backfill shall be placed as specified in Subparagraph D.2. above. Backfilling shall not commence until concrete to be covered has been inspected and approved.

E. Foundation Preparation:

1. The existing ground beneath the equipment base slabs shall be compacted to a density of not less than 95 percent of its maximum density as determined by AASHTO T 180 for a depth of not less than (2)-feet below the bottom of the concrete slabs. Any unsuitable foundation material shall be removed and replaced with suitable material.
2. Slabs on Grade: Subgrades for concrete slabs shall be cut, filled and compacted to the required grade. The top 8-inches of concrete slab subgrade in cut sections and all fill material shall be compacted to a density of not less than 95 percent of its maximum density as determined by AASHTO Designation T-180.

END OF SECTION

SECTION 31 20 17
RECYCLED CRUSHED CONCRETE BASE

PART 1 - GENERAL

1.1 WORK INCLUDED

- A. The work specified in this Section consists of the construction of a base course composed of recycled crushed concrete. It shall be constructed upon the prepared subgrade in accordance with these specifications and in conformity with the lines, grades, notes and typical cross section shown on the Drawings.

1.2 QUALITY ASSURANCE

- A. Laboratory analysis shall be complete, and the material accepted by the Engineer prior to placement.
- B. All work to be in compliance with Florida DOT " Standard Specifications for Road and Bridge Construction", latest edition Section 204 for "Graded Aggregate Base", and geotechnical engineer's report recommendations.
- C. Contractor to employ and pay for a qualified independent geotechnical testing and inspection laboratory to perform testing and inspection services during operations.

PART 2 - PRODUCTS

2.1 MATERIALS

- A. Source: The graded aggregate material used in recycled crushed concrete base courses shall be produced from an approved source which yield a satisfactory mixture conforming to all requirements of these specifications after it has been crushed and processed as a part of the mining operations.
- B. Composition:
 - 1. The recycled crushed concrete shall be reclaimed portland cement concrete crushed and processed to provide a clean, hard, durable aggregate having a uniform gradation free from adherent coatings, steel reinforcement vegetable matter, base material, joint fillers, or bituminous materials. The processing shall be controlled in accordance with the Florida Department of Transportation Standard Operating Procedure for Evaluation Approval and Control of Mineral Aggregate Sources.
 - 2. The material may be furnished in two sizes of such gradation that when combined, in a central mix plant (pugmill), the resultant mixture conforms to the required specifications. Graded aggregate base material shall conform to the following gradation.

C. Gradation:

Sieve Size	Percent by Weight Passing
2"	100
1-1/2"	95 – 100
3/4"	65 – 90
3/8"	45 – 90
No. 4	35 – 60
No. 10	25 – 45
No. 50	5 – 25
No. 200	0 - 10

For Group 1 aggregates, the fraction passing the No. 40 sieve shall have a Plasticity Index (AASHTO T 90) of not more than 4.0 and Liquid Limit (AASHTO T 89) of not more than 25, and contain not more than 2/3 of the weight passing the No. 200 sieve.

For Group 2 aggregates, the material passing the No. 10 sieve shall have a sand equivalent (AASHTO T 176) value of not less than 28.

In the Contractor's opinion, graded aggregate of either Group 1 or Group 2 may be used, but only one group may be used on any contract. (Graded aggregate may be referred to hereinafter as "aggregate".)

D. Quality:

1. The graded aggregate base material shall be of uniform quality throughout, substantially free from vegetable matter, shale, lumps and clay balls. The material retained on the No. 10 sieve shall be composed of aggregate meeting the following requirements:

Soundness Loss, Sodium, Sulfate: AASHTO T 104	15%
Percent Wear: AASHTO T 96 (Grading A)	
Group 1 Aggregates.	45%
Group 2 Aggregates.	65%
Group 1: This group of aggregates shall be limestone, marble dolomite.	
Group 2: This group of aggregates shall be granite, gneiss, or quartzite.	

2. Recycled crushed concrete material shall have an average LBR value of not less than 100.

3.1 GENERAL

- A. Equipment: All equipment necessary for the proper construction of the work shall be on the project, first-class working condition, and shall have been approved by the Engineer prior to its use. The aggregate shall be spread by mechanical aggregate spreaders, equipped with a device which strikes off the aggregate uniformly to laying thickness, and capable of producing an even distribution of the aggregate. For cross-overws, intersections and ramp areas, roadway widths of 20 feet or less, and for any other areas where the use of a mechanical spreader is not practicable, spreading may be done by bulldozers or blade graders.

- B. Limits of Construction: The Contractor shall construct the base to the full width shown on the Drawings.

3.2 PERFORMANCE

- A. Transporting Recycled Crushed Concrete: The recycled crushed concrete shall be transported to the point where it is to be used, over aggregate previously placed if practicable, and dumped on the end of the preceding spread. No hauling over the subgrade or dumping on the subgrade shall be done.
- B. Spreading Recycled Crushed Concrete:
 - 1. The recycled crushed concrete shall be spread uniformly, and all segregated areas of fine or coarse rock shall be removed and replaced with well-graded rock.
 - 2. When the specified compacted thickness of the base is greater than 6 -inches, the base shall be constructed in two courses. The thickness of the first course shall be approximately one-half the total thickness of the finished base, or enough additional to bear the weight of the construction equipment without disturbing the subgrade. At no time shall three (3) days work of the first course be spread and compacted ahead of the second course except where specifically directed by the Engineer.
- C. Compacting and Finishing Base:
 - 1. General:
 - a. For single course base, after spreading is completed, the entire surface shall be scarified and then shaped so as to produce the required grade and cross section after compaction, and shall be free of laminations and segregated material.
 - b. For double course base, the first course shall be cleaned of foreign material, bladed and brought to a surface cross section approximately parallel to that of the finished base. Prior to the spreading of any material for the upper course, the density tests for the lower course shall be made and the Engineer shall have determined that the required compaction has been obtained. After the spreading of material for the second course is completed, its surface shall be finished and shaped so as to produce the required grade and cross section after compaction and free of scabs and Laminations.
 - 2. Moisture Content: When the material does not have the proper moisture content to insure the required density, wetting or drying will be required. If the material is deficient in moisture, water shall be added and uniformly mixed in by dicing the base course to its full depth. If the material contains an excess of moisture, such excess shall be reduced or removed until the required moisture content is attained before being compacted. Wetting or drying operations shall involve manipulation of the entire width and depth of the base as a unit.
 - 3. Density Requirements: As soon as proper conditions of moisture are attained, the material shall be compacted to a density of not less than 98 percent of the maximum density as determined by AASHTO Designation T 180.

4. Density Tests:
 - a. During final compacting operations, if blading of any areas is necessary to obtain the true grade and cross section, the compacting operations for such areas shall be completed prior to making the density determinations on the finished base.
 - b. At least three density determinations shall be made on each day's final operations on each course, and the density determinations shall be made at more frequent intervals if deemed necessary by the Engineer.
5. Correction of Defects:
 - a. If at any time the subgrade material should become mixed with the base course material, the Contractor shall dig out and remove the mixture, reshape and compact the subgrade and replace the materials removed with clean base material, which shall be shaped and compacted as specified above.
 - b. If cracks or checks appear in the base, either before or after priming, which in the opinion of the Engineer would impair the structural efficiency of the base course, the Contractor shall remove such cracks or checks by rescarifying, reshaping, adding base material where necessary and recompacting.
- D. Testing Surface: The finished surface of the base course shall be checked with a templet cut to required crown and cross section and with a 10-foot straightedge laid parallel to the centerline of the road. All irregularities greater than 1/4-inch shall be corrected by scarifying and removing or adding recycled crushed concrete as may be required, after which the entire area shall be recompacted as specified hereinbefore.
- E. Thickness Determinations:
 1. The thickness of the compacted recycled crushed concrete base shall be measured at intervals of not more than 200-feet. Measurements shall be taken at various points on the cross sections prior to the application of the prime coat.
 2. The measurements shall be taken in holes through the base of not less than 3-inches in diameter. Where the compacted base is deficient by more than 1/2-inch from the thickness called for on the Drawings, the Contractor shall correct such areas by scarifying and adding recycled crushed concrete. The base shall be scarified and rock added for a distance of 100-feet in each direction from the edge of the deficient area. The affected areas shall then be brought to the required state of compaction and to the required thickness and cross section.
- F. Priming and Maintaining:
 1. The prime coat shall be applied only when the base meets the specified density requirements and the moisture content in the top half of the base does not exceed 90 percent of the optimum moisture content of the base material. At the time of priming, the base shall be firm and unyielding.

Contract 17-C-00018; Lois Pumping Station Driveway

2. The Contractor will be responsible for assuring that the true crown and grade are maintained with no rutting or other distortion and that the base meets all the requirements at the time the surface course is applied. Care shall be taken to remove all loose dust, dirt and objectionable matter. If deemed necessary, the base shall be slightly sprinkled with water in advance of the prime coat.
3. The temperature of the prime material shall be such as to insure uniform distribution. The material shall be applied with a pressure distributor. The amount to be applied shall be sufficient to coat the surface thoroughly and uniformly without any excess to form pools or to flow off the base. The base shall be primed by the application of approximately 0.15 gallons per square yard of RC-70 meeting the requirements of Section 914-2 of the Standard Specification, Asphalt Emulsion Prime (AEP) meeting the requirements of Section 916-4 of the Standard Specifications, or other materials approved by the Engineer. Cutback asphalt shall conform to the requirements of AASHTO Designation M 81.
4. Following the application of the prime material, a light uniform application of clean sand shall be applied and rolled with a traffic roller, for the full width of the base. The sand shall be non-plastic, shall be free from silt and rock particles and shall not contain any sticks, vegetation, grass, roots or organic matter. After the sand covering has been applied and rolled, the surface may be opened to traffic.

END OF SECTION

SECTION 31 20 19
SELECTIVE DEMOLITION

PART 1 - GENERAL

1.1 SUMMARY

- A. Section Includes:
 - 1. Demolition and removal of site elements.
 - 2. Required demolition is indicated on the drawings.
- B. Related Sections:
 - 1. Section 311100 - Earthwork.

1.2 SUBMITTALS

- A. Proposed Demolition Activities:
 - 1. Submit proposed schedule of demolition activities. Indicate: Starting and ending dates for each activity as appropriate. Interruption and restoration of utility services.
 - 2. Submit proposed methods of operations.
 - 3. Submit proposed dust control measures.
 - 4. Submit proposed noise control measures.
 - 5. Submittal of proposed demolition activities will be reviewed by the Owner only to determine that proposed activities will not interfere with the Owner's operations.
- B. Project Record Documents:
 - 1. Indicate unanticipated structural, electrical, or mechanical conditions.

1.3 PROJECT CONDITIONS

- A. Occupancy: (NOT OCCUPIED)
- B. Existing Conditions:
 - 1. After the project is begun, the contractor is responsible for the condition of structures to be demolished. The owner does not warrant that the condition of structures to be demolished will not have changed since the time of inspection for bidding purposes.
- C. Unforeseen Conditions: Should unforeseen conditions be encountered that affect design or function of project, investigate fully and submit an accurate, detailed, written report to the owner. While awaiting the owner's response, reschedule operations if necessary to avoid delay of overall project.

PART 2 - PRODUCTS (NOT USED)

PART 3 - EXECUTION

3.1 EXAMINATION

- A. Verify that utilities have been disconnected and sealed.
- B. Survey existing conditions and correlate with drawings and specifications to determine extent of demolition required.
- C. Insofar as is practicable, arrange operations to reveal unknown or concealed structural conditions for examination and verification before removal of demolition.
- D. Verify actual conditions to determine in advance whether removal or demolition of any element will result in structural deficiency, overloading, failure, or unplanned collapse.

3.2 PREPARATION

- A. Traffic: Do not obstruct walks or public ways without the written permission of the owner. Where routes are permitted to be closed, provide alternate routes if required.
- B. Protection:
 - 1. Provide for the protection of persons passing around or through the area of demolition.
 - 2. Perform demolition so as to prevent damage to adjacent improvements and facilities to remain.
 - 3. Erect temporary protection such a walks, fences, railings, canopies, etc., where required by the owner.
 - 4. Protect walls, floors, and other new or existing work from damage during demolition operations.
- C. Structural Support:
 - 1. Construct and maintain shoring, bracing, and supports as necessary to ensure the stability of structures.
 - 2. Increase or add new supports as required by the progress of the work.
- D. Damages: Without cost to the owner and without delay, repair any damages caused to facilities to remain.

3.3 UTILITY SERVICES

- A. No interruption of utilities will be permitted.
Provide temporary utilities when existing utilities are interrupted.

3.4 EXPLOSIVES

- A. Do not use explosives.

3.5 POLLUTION CONTROLS

- A. Control as much as practicable the spread of dust and dirt.
- B. Observe environmental protection regulations.
- C. Do not allow water usage that results in freezing or flooding.

3.6 DEMOLITION – GENERAL

- A. Remove: Unless items are otherwise indicated to be reinstalled or salvaged, remove and scrap.
- B. Remove and Salvage: Items indicated to be salvaged will remain the owner's property. Carefully remove and clean items indicated to be salvaged; pack or crate to protect against damage; identify contents of containers; deliver to the locations indicated.
- C. Remove and Scrap: Remove and dispose of items indicated.
 - 1. All demolished or removed items and materials shall be considered scrap except for those indicated to remain, those indicated to be reinstalled, and those indicated to be salvaged.
 - 2. Items of value to the contractor:
 - a. Removed items shall not be stored on site.
- D. Existing to Remain: Construction or items indicated to remain shall be protected against damage during demolition operations. Where practicable, and with the owner's permission, the contractor may elect to remove items to a suitable storage location during demolition and then properly clean and reinstall the items.
- E. Perform work in a systematic manner.
- F. Remove debris daily.
- G. Use any methods permitted by governing regulations and the requirements of the contract documents.
- H. Demolition shall include the removal of all electrical wiring and equipment, as well as mechanical piping, and equipment, both above and below ground.
- I. Demolition of the existing horticultural area including the access road, parking lots, curbs and lighting shall be scheduled to occur after the new horticultural area is operational, or as otherwise directed by the owner.

3.7 DEMOLITION ON OR BELOW GRADE

- A. Where portions of concrete slabs-on-grade are to be removed, first outline the portion with a concrete saw to a depth of at least 1 inch.
- B. Remove concrete slabs-on-grade.
- C. Completely remove below-grade construction, including foundations, footings, piping, and drainage structures.

3.8 FILLING BELOW-GRADE AREAS AND VOIDS

- A. Below-grade areas and voids resulting from demolition of structures, drainage structures and all piping shall be filled or excavated further, as appropriate.

3.9 DISPOSAL OF DEMOLISHED MATERIALS

- A. Promptly dispose of materials resulting from demolition operations. Do not allow materials to accumulate on site.
- B. Transport materials resulting from demolition operations and legally dispose of off-site.
- C. Do not burn removed materials on project site.
- D. Remove decayed, vermin-infested, or otherwise dangerous or unsuitable materials and promptly dispose of off-site.

3.10 CLEANING

- A. Remove tools and equipment. Dispose of scrap.
- B. Leave exterior areas free of debris.

END OF SECTION