

The Enclosed Document Is Provided For Your Convenience.

Please Email ALL Questions:

[MailTo:ContractAdministration@TampaGov.net](mailto:ContractAdministration@TampaGov.net)

Please Let Us Know If You Plan To Bid

City of Tampa
Contract Administration Department
306 E. Jackson St. #280A4N
Tampa, FL 33602
(813)274-8456

CITY OF
TAMPA, FLORIDA

NOTICE TO BIDDERS, INSTRUCTIONS TO BIDDERS
PROPOSAL, BID BOND, FORM OF NOTICE OF AWARD,
AGREEMENT, PERFORMANCE BOND AND
SPECIFICATIONS

FOR

Contract 14-C-00008

**ROADWAY RESTORATION - WATER DEPARTMENT
REBID**

City of Tampa
CONTRACT ADMINISTRATION DEPARTMENT
TAMPA MUNICIPAL OFFICE BUILDING
306 E. JACKSON STREET - 4TH FLOOR NORTH
TAMPA, FLORIDA 33602

FEBRUARY 2014

CITY OF TAMPA
CONTRACT ADMINISTRATION DEPARTMENT
306 E. Jackson Street 280A4N
Tampa, FL 33602

BID NOTICE MEMO

Bids will be received no later than 1:30 p.m. on the indicated Date(s) for the following Project(s):

CONTRACT NO.: 14-C-00008; Roadway Restoration – Water Department Rebid

BID DATE: March 11, 2014 **ESTIMATE:** \$350,000 **SCOPE:** The project comprises construction of various roadway restoration improvements including street resurfacing, driveway repair, installing sidewalks and other associated surface restoration. **PRE-BID CONFERENCE:** Tuesday, February 25, 2014, 2:00 p.m. Attendance is not mandatory, but recommended.

Bids will be opened in the 4th Floor Conference Room, Tampa Municipal Office Building, 306 E. Jackson Street, Tampa, Florida 33602. Pre-Bid Conference is held at the same location unless otherwise indicated. Plans and Specifications and Addenda for this work may be examined at, and downloaded from, www.demandstar.com. Backup files are available at http://www.tampagov.net/dept_contract_administration/programs_and_services/construction_project_bidding/index.asp. Subcontracting opportunities may exist for City certified Small Local Business Enterprises (SLBEs). A copy of the current SLBE directory may be obtained at www.Tampagov.net. Phone (813) 274-8456 for assistance. **Email Technical Questions to:** contractadministration@tampagov.net .

TABLE OF CONTENTS

BIDDING REQUIREMENTS

Notice to Bidders N-1
 Instructions to Bidders I-1a thru I-4
 Insurance Requirements..... INS-1 thru INS-2
 SLBE Goal Setting List GS-1
 Goal Setting List Instructions..... GSL-1
 Sample Solicitation Letter SL-1

BID FORMS

Proposal P-1 thru P-8
 Good Faith Efforts Compliance Plan..... GFCEP
 SLBE Solicited..... DMI - Solicited
 SLBE Utilized..... DMI - Utilized
 Bid Bond BB-1

CONTRACT FORMS

Agreement A-1 thru A-15
 Public Construction Bond..... PB-1 thru PB-3

GENERAL PROVISIONS

General Provisions G-1 thru G-10
 Subcontractors Payment Form DMI - Payments
 Project Sign Sign-1 thru Sign-2

SPECIFIC PROVISIONS

S1.0 GENERAL SP-1
 S2.0 DEFINITIONS SP-1
 S3.0 APPLICABLE CODES OR STANDARDS SP-1
 S4.0 PERIOD OF CONTRACT SP-2
 S4.1 BASIS OF AWARD/CONTRACT PRICE SP-2
 S4.2 TIME PROVISIONS SP-2
 S5.0 LICENSES AND PERMITS SP-3
 S6.0 LIQUIDATED DAMAGES SP-3
 S7.0 WORK DIRECTIVE CHANGE SP-3
 S8.0 DEFECTIVE MATERIALS SP-3
 S9.0 WORK PERFORMED ON SATURDAYS, SUNDAYS, LEGAL HOLIDAYS,
 OR AFTER REGULAR WORKING HOURS SP-4
 S10.0 CONFLICTS WITH PROPOSED WORK SP-4
 S11.0 TEMPORARY FACILITIES AND CONTROLS SP-4
 S12.0 MAINTENANCE AND RESTORATION OF JOB SITE SP-6
 S13.0 USE OF EXPLOSIVES SP-7
 S14.0 GRADES AND DRAINAGE AT STREET INTERSECTIONS SP-7
 S15.0 ENVIRONMENTAL PROTECTION SP-7
 S16.0 USE OF PRIVATE PROPERTY SP-8
 S17.0 TREE PROTECTION SP-8
 S18.0 STANDARD DETAILS SP-8
 S19.0 WORKER SAFETY SP-8
 S20.0 CONTRACTOR'S PRESENCE SP-8
 S21.0 EMERGENCY MOBILIZATION SP-8

CONTRACT PAY ITEMS

| | |
|--|------|
| C1.00 GENERAL | CP-1 |
| C2.00 RESTORATION & MISCELLANEOUS INCIDENTAL ITEMS | CP-2 |
| C2.10 General | CP-2 |
| C2.20 Pavement | CP-2 |
| C3.00 Roadside Restoration | CP-4 |
| C4.00 Emergency Mobilization Fee | CP-5 |
| C5.00 Owner Contingency Allowance | CP-5 |
| C6.00 One-Time Performance Bond Allowance | CP-6 |
| C7.00 Mobilization for Small Projects | CP-6 |

TECHNICAL SPECIFICATIONS

| | |
|--|-------|
| T1.00 GENERAL REQUIREMENTS | TS-1 |
| T1.01 Summary of Work | TS-1 |
| T1.02 Coordination | TS-1 |
| T1.03 Abbreviations and Symbols | TS-2 |
| T1.04 Submittals, Shop Drawings, Product Data and Samples | TS-3 |
| T1.05 Quality Control | TS-4 |
| T1.06 Materials and Equipment | TS-4 |
| T1.07 Cleaning and Restoring | TS-5 |
| T2.00 RESTORATION | TS-6 |
| T2.01 Waste Material Disposal | TS-6 |
| T2.02 PAVEMENT/RIGHT-OF-WAY RESTORATION REQUIREMENT (REV.2009) | TS-6 |
| T2.03 VITRIFIED BRICK REPLACEMENT (REVISED 4/27/2009) | TS-12 |
| T2.04 Pavement Marking | TS-13 |

STANDARD DETAILS

| | |
|--|--|
| STANDARD DETAILS FOR RESTORATION WITHIN ROADWAY FLEXIBLE PAVEMENT | |
| STANDARD DETAILS FOR RESTORATION WITHIN ROADWAY RIGID PAVEMENT | |
| 2.01 TRENCHING, BEDDING AND BACKFILL FOR NON-PERVIOUS (paved) AREAS | |
| 2.02 TRENCHING, BEDDING AND BACKFILL OR NON-PERVIOUS (non-paved) AREAS | |
| 9.01 CITY OF TAMPA PROJECT SIGN | |
| STANDARD DETAILS FOR RESTORATION WITHIN ROADWAY | |

NOTICE TO BIDDERS
CITY OF TAMPA, FLORIDA
Contract 14-C-00008; Roadway Restoration - Water Department - Rebid

Sealed Proposals will be received by the City of Tampa no later than 1:30 P.M., March 11, 2014, in the 4th Floor Conference Room, Tampa Municipal Office Building, 306 E. Jackson Street, Tampa, Florida, there to be publicly opened and read aloud.

The proposed work is to include, but not be limited to, construction of various roadway restoration improvements including street resurfacing, driveway repair, sidewalk construction, other associated surface restoration with all associated work required for a complete project in accordance with the Contract Documents.

The Instructions to Bidders, Proposal, Form of Bid Bond, Agreement, Form of Public Construction Bond, Specifications, Plans and other Contract Documents are posted at DemandStar.com. Backup files may be downloaded from http://www.tampagov.net/dept_contract_administration/programs_and_services/construction_project_bidding/index.asp. One set may be available for reference at the office of the Contract Administration Department, Municipal Office Building, Fourth Floor North, City Hall Plaza, Tampa, Florida 33602.

Each Proposal must be submitted on the Proposal form included in the Specifications and must be accompanied by a certified check or cashier's check on a solvent bank or trust company in compliance with Section 255.051, Florida Statutes, made payable to the City of Tampa, in an amount of not less than five per cent of the total bid, or a Bid Bond, of like amount, on the form set forth in the Contract Documents, as a guarantee that, if the Proposal is accepted, the Bidder will execute the Proposed Contract and furnish Performance and Payment Bonds within twenty (20) days after receipt of Notice of Award of Contract.

The City of Tampa reserves the right to reject any or all Bids and to waive any informalities in the Bid and/or Bid Bond. Acceptance or rejection of Proposals will be made as soon as practicable after the Proposals are received, but the City reserves the right to hold Proposals for ninety (90) days from the date of Opening.

Bid Protest Procedures: Unless subsequently indicated otherwise, in a revised posting on the Department's web page for Construction Project Bidding, the City of Tampa intends to award the referenced project to the lowest bidder listed in the tabulation posted on or about the date of Bid Opening. A bidder aggrieved by this decision may file a protest not later than 4:30 P.M., five (5) business days from the first posting thereof, pursuant to City of Tampa Code Chapter 2, Article V, Division 3, Section 2-282, Procurement Protest Procedures. Protests not conforming therewith shall not be reviewed.

Communication with City Staff

Pursuant to City of Tampa Ordinance 2010-92, during the solicitation period, including any protest and/or appeal, NO CONTACT initiated by bidders or responders with City officers or employees, other than the individuals specified below is permitted:

Director of Contract Administration, David Vaughn

Contracts Management Supervisor, Jim Greiner

Contract Officer, Jody Gray

The City's Legal Department staff

The City's Contract Administration Department staff.

Technical Questions and Requests For Information should be directed to the Department via

ContractAdministration@tampagov.net

"A person or affiliate who has been placed on the convicted vendor list following a conviction for a public entity crime may not submit a bid on a contract to provide any goods or services to a public entity, may not submit a bid on a contract with a public entity for the construction or repair of a public building or public work, may not submit bids on leases of real property to a public entity, may not be awarded or perform work as a contractor, supplier, subcontractor, or consultant under a contract with any public entity, and may not transact business with any public entity in excess of the threshold amount provided in Section 287.017, for CATEGORY TWO for a period of 36 months from the date of being placed on the convicted vendor list." Refer to Section 287.133 Florida Statutes.

In accordance with the City of Tampa's Equal Business Opportunity Ordinance, a Goal may have been established for subcontracting with Small Local Business Enterprises, SLBEs, certified by the City. Links to further information and a list of SLBEs are on the Department's Construction Project Bidding Web page. A link to the current complete directory of SLBEs is on the Minority Business Development Office Website.

INSTRUCTIONS TO BIDDERS
SECTION 1 - SPECIAL INSTRUCTIONS

I-1.01 GENERAL:

The proposed work is the Roadway Restoration - Water Department - Rebid in the City of Tampa, as required for a complete project, as shown on the plans and detailed in the specifications. The work is located on land owned or controlled by the City of Tampa.

I-1.02 FORM PREPARATION AND PRESENTATION OF PROPOSALS: Replace the second sentence with the following: Submission of the entire specification book is not required.

I-1.03 ADDENDA – Section I-2.03 is replaced with the following: No interpretation of the meaning of the Plans, Specifications, or other Contract Documents will be made to any Bidder orally.

Every request for such interpretation must be in writing, addressed to the City of Tampa, Contract Administration Department, 306 E. Jackson St., 4th Floor, Tampa, Florida 33602 and then emailed to ContractAdministration@tampagov.net. To be given consideration, such request must be received at least seven (7) days prior to the date fixed for the opening of the Proposals. Any and all such interpretations and any supplemental instructions will be in the form of written addenda which, if issued, will be posted on DemandStar.Com and on the Department's web page, with notice given to all prospective bidders at the respective fax numbers or e-mail addresses furnished, for such purposes. Failure of any Bidder to receive any such addenda shall not relieve said Bidder from any obligation under his Proposal as submitted. All addenda so issued shall become part of the Contract Documents.

I-1.04 SIGNATURE OF BIDDERS: Section I-2.07 is replaced with the following:

Proposals must be signed in ink by the Bidder with signature in full. When firm is a Bidder, the Proposal shall be signed in the name of the firm by one or more partners. When a corporation is a bidder the officer signing shall set out the corporate name in full beneath which he shall sign his name and give the title of his office. The Proposal shall also bear the seal of the corporation attested by its secretary.

If the bidder referred to in Section I-2.07 is a corporation, it must submit; upon request, a copy of its filed Articles of Incorporation. In addition, if the bidder was incorporated in another state, it must establish that it is authorized to do business in the State of Florida. If the bidder is using a fictitious name, it must submit upon request, proof of registration of such name with the Clerk of the Circuit Court of the Country where its principal place of business is. Failure to submit what is required is grounds to reject the bid of that bidder.

I-1.05 TIME FOR COMPLETION:

The work shall be arranged to be completed in accordance with a progress schedule approved by the Construction Engineer.

The time for completion of this project, referred in Article 4.01 of the Agreement, shall be 365 consecutive calendar days. The period for performance shall start from the date indicated in the Notice To Proceed.

I-1.06 LIQUIDATED DAMAGES:

The amount of liquidated damages, referred to in Article 4.06 of the Agreement, for completion of this project shall be \$250.00 per calendar day. See S6.0 on page SP-3.

I-1.07 BASIS OF AWARD OF CONTRACT:

The basis of award referred to in Item I-2.11 of Instructions to Bidders shall be the greatest amount of work, which can be accomplished within the funds available as budgeted. The award may be made on the basis of the total bid, base bid, alternates(s) if any, unit bids if any, or any combination thereof deemed to be in the best interest of the City.

INSTRUCTIONS TO BIDDERS
SECTION 1 - SPECIAL INSTRUCTIONS

Unless all bids are rejected, the award will be made within 90 days after opening proposals.

I-1.08 GROUND BREAKING CEREMONY:

Arrangement may be made by the City in coordination with the Contractor, for construction to commence with a Ground Breaking Ceremony. Details will be discussed at the pre-construction conference.

I-1.09 INSURANCE:

The insurance required for this project shall be as indicated on Pages beginning with INS-1. Before commencing work, the Contractor shall provide the evidence of the insurance required on a Certificate of Insurance accompanied by evidence of authority to bind the insurance company or companies such as agents license, power of attorney, or letter of authority.

I-1.10 EQUAL BUSINESS OPPORTUNITY PROGRAM / SLBE / REQUIREMENTS

In accordance with the City of Tampa's Equal Business Opportunity Ordinance, a goal of 13.9% has been established for subcontracting with Small Local Business Enterprises, (SLBEs), certified by the City. The goal is based upon the availability of the firms listed on the Goal Worksheet and as posted in the "SLBEs" link under this Contract's notice on the Department's Construction Project Bidding web page.

BIDDERS MUST SOLICIT ALL SLBEs ON THAT LIST and provide documentation of emails, faxes, phone calls, letters, or other communication with the firms as a first step to demonstrate Good Faith Efforts to achieve the goal. The list is formatted to facilitate e-mail solicitations to the listed firms by copying and pasting e-mail addresses.

Bidders may explore other opportunities for subcontracting with SLBEs by consulting the current directory of all certified SLBEs posted on the Minority Business Development Office web page.

GOOD FAITH EFFORT COMPLIANCE PLAN REQUIRED - When a Goal has been established, the Bidder must submit, with its bid, completed to the fullest extent possible, a Good Faith Effort Compliance Plan using the form GFECF contained herein. Additional documentation is required whenever an SLBE subcontractor's low quote is not utilized. Supplemental information or documentation concerning the Bidder's Compliance Plan may be required prior to award as requested by the City.

DIVERSITY MANAGEMENT INITIATIVE, DMI, DATA REPORTING FORMS REQUIRED - Bidders must submit, with its bid, "DMI-Solicited" forms listing all subcontractors solicited and "DMI-Utilized" forms listing all subcontractors to be utilized. Supplemental forms, documentation, or information may be submitted at bid time or as requested by the City.

After an award, "DMI-Payments" forms are to be submitted with payment requests to report payments to subcontractors.

Bidders may visit the Minority Business Development Office's web page at TampaGov.net for other information about the SLBE program, FAQ's, and the latest SLBE directory of certified firms.

I-1.11 BID SECURITY:

Surety companies shall have a rating of not less than B+ Class VI as evaluated in the most recently circulated Best Key rating Guide Property-Liability.

I-1.12 PUBLIC CONSTRUCTION BOND:

The Bidder who is awarded the Contract will be required to furnish a Public Construction Bond upon the forms provided herein, each equal to 100 percent of the Contract price, such Bonds to be issued and executed by (a) surety company(ies) acceptable to the City of Tampa and licensed to underwrite contracts in the State of Florida.

INSTRUCTIONS TO BIDDERS
SECTION 1 - SPECIAL INSTRUCTIONS

I-1.13 AGREEMENT

Section 2 – Powers of the City's Representatives

Add the following:

Article 2.05 CITY'S TERMINATION FOR CONVENIENCE:

The City may, at any time, terminate the Contract in whole or in part for the City's convenience and without cause. Termination by the City under this Paragraph shall be by a notice of termination delivered to the Contractor, specify the extent of termination and the effective date.

Upon receipt of a notice of termination, the Contractor shall immediately, in accordance with instructions from the City, proceed with performance of the following duties regardless of delay in determining or adjusting amounts due under this Paragraph:

- (a) cease operations as specified in the notice;
- (b) place no further orders and enter into no further subcontracts for materials, labor, services or facilities except as necessary to complete continued portions of the Contract;
- (c) terminate all subcontracts and orders to the extent they relate to the Work terminated;
- (d) proceed to complete the performance of Work not terminated; and
- (e) take actions that may be necessary, or that the City may direct, for the protection and preservation of the terminated Work.

The amount to be paid to the Contract by the City because of the termination shall consist of:

- (a) for costs related to work performed on the terminated portion of the Work prior to the effective date including termination costs relative to subcontracts that are properly chargeable to the terminated portion of the Work.
- (b) the reasonable costs of settlement of the Work terminated, including accounting, legal, clerical and other expenses reasonable necessary for the preparation of termination settlement proposals and supporting data; additional costs of termination and settlement of subcontracts excluding amounts of such settlements; and storage, transportation, and other costs incurred which are reasonably necessary for the preservation, protection or disposition of the terminated Work; and
- (c) a fair and reasonable profit on the completed Work unless the Contractor would have sustained a loss on the entire Contract had it been completed.

Allowance shall be made for payments previously made to the Contractor for the terminated portion of the Work, and claims which the City has against the Contractor under the Contract, and for the value of materials supplies, equipment or other items that are part of the costs of the Work to be disposed of by the Contractor.

I-1.14 Section 5 – subcontracts and Assignments, Article 5.01, Page A-7, Last Paragraph:
Change "...twenty-five (25) percent..." to "fifty-one (51) percent..."

Section 10-Payments, Article .05 Partial Payments, 1st Paragraph, 1st Sentence:

Change "...fair value of the work done, and may apply for..." to "...fair value of the work done, and shall apply for..."

I-1.15 Contractors must utilize the U.S. Department of Homeland Security's E-Verify Systems to verify the employment eligibility of all persons employed during the term of the contract to perform employment duties within the State of Florida and all persons, including subcontractors, assigned by the contractor to perform work pursuant to the contract.

I-1.16 GENERAL PROVISIONS; G-2.02 Copies Furnished to Contractor: Replace the first paragraph with the following:

The Contractor shall acquire for its use copies of the plans and specifications as needed. The documents may be downloaded from the City's web site, at

http://www.tampagov.net/dept_contract_administration/programs_and_services/construction_project_bidding/index.asp

I-1.17 PAYMENT DISPUTE RESOLUTION

Any dispute pertaining to pay requests must be presented to the City pursuant to Executive Order 2003-1.

INSTRUCTIONS TO BIDDERS
SECTION 1 - SPECIAL INSTRUCTIONS

I-1.18 SCRUTINIZED COMPANIES.

For Contracts \$1,000,000 and greater, if the City determines the Contractor submitted a false certification under Section 287.135(5) of the Florida Statutes, or if the Contractor has been placed on the Scrutinized Companies with Activities in the Sudan List or the Scrutinized Companies with Activities in the Iran Petroleum Energy Sector List, the City shall either terminate the Contract after it has given the Contractor notice and an opportunity to demonstrate the City's determination of false certification was in error pursuant to Section 287.135(5)(a) of the Florida Statutes, or maintain the Contract if the conditions of Section 287.135(4) of the Florida Statutes are met.

I-1.19 FLORIDA'S PUBLIC RECORDS LAW

- 4.33.3 The City of Tampa is a public agency subject to Chapter 119, Florida Statutes. In accordance with Florida Statutes, 119.0701, if applicable, Contractor shall comply with Florida's Public Records Law. Specifically, the Contractor shall:
1. Keep and maintain public records that ordinarily and necessarily would be required by the City in order to perform the service;
 2. Provide the public with access to such public records on the same terms and conditions that the City would provide the records and at a cost that does not exceed that provided in Chapter 119, Florida Statutes, or as otherwise provided by law;
 3. Ensure that public records that are exempt or that are confidential and exempt from public record requirements are not disclosed except as authorized by law;
 4. Meet all requirements for retaining public records and transfer to the City, at no cost, all public records in possession of the contractor upon termination of the contract and destroy any duplicate public records that are exempt or confidential and exempt. All records stored electronically must be provided to the City in a format that is compatible with the information technology systems of the agency.
- 4.33.4 The failure of Contractor to comply with the provisions set forth in this Article shall constitute a Default and Breach of this award and the City shall enforce the Default in accordance with the provisions set forth in the DEFAULT/RE-AWARD section of this document.

CITY OF TAMPA INSURANCE REQUIREMENTS

During the life of the award/contract the Awardee/Contractor shall provide, pay for, and maintain insurance with companies authorized to do business in Florida, with an A.M. Best rating of B+ (or better) Class VII (or higher), or otherwise be acceptable to the City if not rated by A.M. Best. All insurance shall be from responsible companies duly authorized to do business in the State of Florida.

All commercial general liability insurance policies (and Excess or Umbrella Liability Insurance policies, if applicable) shall provide that the City is an additional insured as to the operations of the Awardee/Contractor under the award/contract including the additional insured endorsement, the subrogation waiver endorsement, and the Severability of Interest Provision. In lieu of the additional named insured requirement, if the Awardee/Contractor's company has a declared existing policy which precludes it from including additional insureds, the City may permit the Contractor to purchase an Owners and Contractors Protective Liability policy. Such policy shall be written in the name of the City at the same limit as is required for General Liability coverage. The policy shall be evidenced on an insurance binder which must be effective from the date of issue until such time as a policy is in existence and shall be submitted to the City in the manner described below as applicable to certificates of insurance.

The insurance coverages and limits required must be evidenced by a properly executed Acord 25 Certificate of Insurance form or its equivalent. Each Certificate must be personally manually signed by the Authorized Representative of the insurance company shown in the Certificate with proof that he/she is an authorized representative thereof. Thirty days' written notice must be given to the City of any cancellation, intent not to renew, or reduction in the policy coverages, except in the application of the aggregate liability limits provisions. Should any aggregate limit of liability coverage be reduced, it shall be immediately increased back to the limit required by the contract. The insurance coverages required herein are to be primary to any insurance carried by the City or any self-insurance program thereof.

The following coverages are required:

A. Commercial General Liability Insurance shall be provided on the most current Insurance Services Office (ISO) form or its equivalent. This coverage must be provided to cover liability arising from premises and operations, independent contractors, products and completed operations, personal and advertising injury, contractual liability, and XCU exposures (if applicable). Completed operations liability coverage shall be maintained for a minimum of one-year following completion of work. The amount of Commercial General Liability insurance shall not be less than the amount specified.

(a) \$1,000,000 per occurrence and a \$2,000,000 general aggregate for projects valued at \$2,000,000 or less. General aggregate limit for projects over that price shall equal or exceed the price of the project. An Excess or Umbrella Liability insurance policy can be provided to meet the required limit. Risk Management may be contacted for additional information regarding projects of this nature.

B. Automobile Liability Insurance shall be maintained in accordance with the laws of the State of Florida, as to the ownership, maintenance, and use of all owned, non-owned, leased, or hired vehicles. The amount of Automobile Liability Insurance shall not be less than the amount specified.

(a) \$500,000 combined single limit each occurrence bodily injury & property damage- for projects valued at \$100,000 and under

(b) \$1,000,000 combined single limit each occurrence bodily injury & property damage – for projects valued over \$100,000

C. Worker's Compensation and Employer's Liability Insurance shall be provided for all employees engaged in the work under the contract, in accordance with the Florida Statutory Requirements. The amount of the Employer's Liability Insurance shall not be less than:

(a) \$500,000 bodily injury by accident and each accident, bodily injury by disease policy limit, and bodily injury by disease each employee – for projects valued at \$100,00 and under

(b) \$1,000,000 bodily injury by accident and each accident, bodily injury by disease policy limit, and bodily injury by disease each –for projects valued over \$100,000

D. Excess Liability Insurance or Umbrella Liability Insurance may compensate for a deficiency in general liability, automobile, or worker's compensation insurance coverage limits. If the Excess or Umbrella policy is being provided as proof of coverage, it must name the City of Tampa as an additional insured (**IF APPLICABLE**).

E. Builder's Risk Insurance, specialized policy designed to cover the property loss exposures that are associated with construction of buildings. The amount of coverage should not be less than the amount of the project. **(IF APPLICABLE)**.

F. Installation Floater- a builder's risk type policy that covers specific type of property during its installation, is coverage required for highly valued equipment or materials such as compressors, generators, or other machinery that are not covered by the builder's risk policy **(IF APPLICABLE)**.

G. Longshoreman's & Harbor Worker's Compensation Act/Jones Act coverage shall be maintained for work being conducted upon navigable water of the United States. The limit required shall be the same limit as the worker's compensation/employer's liability insurance limit **(IF APPLICABLE)**.

H. Professional Liability shall be maintained against claims of negligence, errors, mistakes, or omissions in the performance of the services to be performed and furnished by the Awardee/Contractor or any of its subcontractors when it acts as a DESIGN PROFESSIONAL. The amount of coverage shall be no less than amount specified **(IF APPLICABLE)**.

(a) \$1,000,000 per incident and general aggregate. Note all claims made policies must provide the date of retroactive coverage.

The City may waive any or all of the above referenced insurance requirements based on the specific nature of goods or services to be provided under the award/contract.

ADDITIONAL INSURED - The City must be included as an additional insured by on the general and (Excess or Umbrella liability policies) if applicable. Alternatively, the Contractor may purchase a separate owners protective liability policy in the name of the City in the specified amount as indicated in the insurance requirements.

CLAIMS MADE POLICIES - If any liability insurance is issued on a claims made form, Contractor agrees to maintain uninterrupted coverage for a minimum of one year following completion and acceptance of the work either through purchase of an extended reporting provision, or through purchase of successive renewals with a retroactive

date not later than the beginning of performance of work for the City. The retroactive date must be provided for all claims made policies.

CANCELLATION/NON-RENEWAL - Thirty (30) days written notice must be given to the City of any cancellation, intent to non-renew or material reduction in coverages (except aggregate liability limits). However, ten (10) days notice may be given for non-payment of premium. Notice shall be sent to the City of Tampa Department of Public Works, 306 E. Jackson Street, Tampa, FL 33602.

NUMBER OF POLICIES - General and other liability insurance may be arranged under single policies for the full amounts required or by a combination of underlying policies with the balance provided by an excess or umbrella liability insurance policy.

WAIVER OF SUBROGATION - Contractor waives all rights against City, its agents, officers, directors and employees for recovery of damages to the extent such damage is covered under the automobile or excess liability policies.

SUBCONTRACTORS - It is the Contractor's responsibility to require all subcontractors to maintain adequate insurance coverage.

PRIMARY POLICIES - The Contractor's insurance is primary to the City's insurance or any self insurance program thereof.

RATING - All insurers shall be authorized to do business in Florida, and shall have an A.M. Best rating of B+ (or better), Class VII (or higher), or otherwise be acceptable to the City if not rated by A.M. Best.

DEDUCTIBLES - The Contractor is responsible for all deductibles. In the event of loss which would have been covered but for the presence of a deductible, the City may withhold from payment to Contractor an amount equal to the deductible to cover such loss should full recovery not be obtained under the insurance policy.

INSURANCE ADJUSTMENTS - These insurance requirements may be increased, reduced, or waived at the City's sole option with an appropriate adjustment to the Contract price.

Document updated on 12/22/2009 by RLD (Risk Management)

City of Tampa MBD Office
U-WMBE Goal Setting Firms Report
as of 11/5/2013

BARRICADES, TRAFFIC CONES, LANE MARKERS, ETC

Sentry Barricades, Inc.

59-3590342

P.O. Box 3647
820 Creative Drive
Lakeland, FL 33802

E-mail admin@sentryb.com

Phone (863) 682-7098

Fax (863) 680-9901

Federal

Minority African American

Contact Darryl Talley

CONCRETE (CURBS & GUTTERS)

E.S. Concrete Services, Inc.

59-3119582

726 East Harbor Dr. South
St. Petersburg, FL 33705

E-mail enorisslysr@yahoo.com

Phone (727) 821-5029

Fax (727) 821-5029

Federal

Minority African American

Contact Enoris Sly

Paragon Building Contractors, Inc.

59-2464751

1201 W. Waters Ave.
Tampa, FL 33604

E-mail paragonb@tampabay.rr.com

Phone (813) 935-1600

Fax (813) 932-1108

Federal

Minority African American

Contact Al Davis

Denson Construction, Inc.

59-3571944

P.O. Box 3081
Plant City, FL 33564

E-mail Pete@denson-construction.com

Phone (863) 709-1001

Fax (863) 709-1071

Federal

Minority African American

Contact Ralph (Pete) Denson

L.S. Curb Service, Inc.

59-3252745

4206 James L. Redman Pkwy
Plant City, FL 33567

E-mail lshakes@lscurb.com

Phone (813) 737-1524

Fax (813) 650-8654

Federal

Minority African American

Contact Leaford Shakes

CONCRETE (SIDEWALKS, DRIVEWAYS, FORM & FINISH)

E.S. Concrete Services, Inc.

59-3119582

726 East Harbor Dr. South
St. Petersburg, FL 33705

E-mail enorisslysr@yahoo.com

Phone (727) 821-5029

Fax (727) 821-5029

Federal

Minority African American

Contact Enoris Sly

City of Tampa MBD Office
U-WMBE Goal Setting Firms Report
as of 11/5/2013

CONCRETE (SIDEWALKS, DRIVEWAYS, FORM & FINISH)

MIMS Construction Company

59-3442318

P.O. Box 681554
Orlando, FL 32868-1554

E-mail lyndell1111@cs.com

Phone (407) 298-6936
Fax (407) 290-1217

Minority African American
Contact Lyndell Mims

Federal

Paragon Building Contractors, Inc.

59-2464751

1201 W. Waters Ave.
Tampa, FL 33604

E-mail paragonb@tampabay.rr.com

Phone (813) 935-1600
Fax (813) 932-1108

Minority African American
Contact Al Davis

Federal

Denson Construction, Inc.

59-3571944

P.O. Box 3081
Plant City, FL 33564

E-mail Pete@denson-construction.com

Phone (863) 709-1001
Fax (863) 709-1071

Minority African American
Contact Ralph (Pete) Denson

Federal

L.S. Curb Service, Inc.

59-3252745

4206 James L. Redman Pkwy
Plant City, FL 33567

E-mail lshakes@lscurb.com

Phone (813) 737-1524
Fax (813) 650-8654

Minority African American
Contact Leaford Shakes

Federal

Powell Concrete, LLC

83-0467921

1410 Swift Ct.
Kissimmee, FL 34759

E-mail powellconcrete1@yahoo.com

Phone (863) 438-4454
Fax (863) 496-1227

Minority African American
Contact Earl Powell

Federal

Allen Masonry & General Contracting, Inc.

20-1580292

6215 Travis Blvd.
Tampa, FL 33610

E-mail allenmasonrygc@gmail.com

Phone (813) 627-9231
Fax

Minority African American
Contact Steve Allen

Federal

City of Tampa MBD Office
U-WMBE Goal Setting Firms Report

as of 11/5/2013

SOD, SEED SOIL, AND INOCULANTS

Professional Property Services

Federal

59-1341451

10105 11th Street North
Tampa, FL 33612

Phone (813) 972-4057

Fax (813) 971-0882

Minority African American

Contact Hyacinth Robinson

E-mail paulrobinson22@msn.com

Fresh Start Development, Inc.

Federal

20-3857845

P.O. Box 310592
Tampa, FL 33680

Phone (813) 758-5345

Fax (813) 333-5949

Minority African American

Contact Katina McClinton

E-mail freshstartdevelop@yahoo.com

Sterling Silver Scape & Sod, Inc.

Federal

59-3171150

P.O. Box 450459
Kissimmee, FL 34745

Phone (407) 846-3225

Fax (407) 846-3207

Minority African American

Contact Sterling Blake

E-mail jar@sterlingsilverlandscaping.com

Tuesday, November 05, 2013

Page 3 of 3

City of Tampa MBD Office

SLBE Goal Setting Firms Report

as of 11/5/2013



BARRICADES, TRAFFIC CONES, LANE MARKERS, ETC

Sentry Barricades, Inc.

P.O. Box 3647
820 Creative Drive
Lakeland, FL 33802

Phone (863) 682-7098

Fax (863) 680-9901

E-mail admin@sentryb.com

Federal Number 59-3590342

Minority Small Business

Contact Darryl Talley

CONCRETE (CURBS & GUTTERS)

E.S. Concrete Services, Inc.

726 East Harbor Dr. South
St. Petersburg, FL 33705

Phone (727) 821-5029

Fax (727) 821-5029

E-mail enorisslysr@yahoo.com

Federal Number 59-3119582

Minority Small Business

Contact Enoris Sly

Parking Lot Striping Service

P.O. Box 11005
Tampa, FL 33680

Phone (813) 623-1454

Fax (813) 664-0140

E-mail lindaplss@aol.com

Federal Number 59-1522393

Minority Small Business

Contact Fernando Llop

Tampa Bay Construction & Engineering, Inc.

10503 Palm Cove Ave
Tampa, FL 33647

Phone (813) 984-9898

Fax (813) 907-0980

E-mail aerchid@tbcei.com

Federal Number 59-3713572

Minority Small Business

Contact Ahmad Erchid

Chet Netherly, LLC d/b/a Anything in Concrete

246 W Canal Drive
Palm Harbor, FL 34684

Phone (727) 945-7035

Fax (727) 934-0568

E-mail netherlyWCAN@aol.com

Federal Number 20-3926235

Minority Small Business

Contact Chet Netherly

Velez Concrete Construction, Inc.

3926 E. Eden Roc Circle
Tampa, FL 33634

Phone (813) 493-4762

Fax (813) 882-3455

E-mail velezconcrete@verizon.net

Federal Number 83-0373603

Minority Small Business

Contact John Velez

City of Tampa MBD Office

SLBE Goal Setting Firms Report

as of 11/5/2013



CONCRETE (CURBS & GUTTERS)

Tagarelli Construction, Inc.

P.O. Box 681
Tarpon Springs, FL 34689

Phone (727) 937-6171

Fax (727) 937-6172

E-mail tagarelli@verizon.net

Federal Number 59-3339407

Minority Small Business

Contact Michael Tagarelli

Andras Construction Service, LLC

18449 Lake Iola Rd
Dade City, FL 33523

Phone (813) 482-2581

Fax (352) 588-2073

E-mail jeffandras@gmail.com

Federal Number 20-4468935

Minority Small Business

Contact Jeffrey Andras

Velocity Construction, Inc.

1320 E. 137th Ave
Tampa, FL 33613

Phone (813) 624-2117

Fax (800) 807-0314

E-mail bconnor@tampabay.rr.com

Federal Number 74-3082984

Minority Small Business

Contact William Connor

Kilgore Construction, LLC

11697 Walsingham Rd.
Largo, FL 33778

Phone (727) 755-2294

Fax (727) 581-5724

E-mail jo@kilgorellc.com

Federal Number 26-3771464

Minority Small Business

Contact Harold Kilgore

JMJ Site Development, Inc

P.O. Box 1095
Lithia, FL 33547

Phone (813) 927-2484

Fax

E-mail jmjsitedevelopment@gmail.com

Federal Number 27-3413832

Minority Small Business

Contact Jeff Joaquin

CONCRETE (SIDEWALKS, DRIVEWAYS, FORM & FINISH)

Castco Construction, Inc.

9001 126th Ave. North
Largo, FL 33773

Phone (727) 585-4714

Fax (727) 585-5091

E-mail cconstr@tampabay.rr.com

Federal Number 59-2548614

Minority Small Business

Contact Israel Castro

City of Tampa MBD Office



SLBE Goal Setting Firms Report

as of 11/5/2013

CONCRETE (SIDEWALKS, DRIVEWAYS, FORM & FINISH)

E.S. Concrete Services, Inc.

726 East Harbor Dr. South
St. Petersburg, FL 33705

Phone (727) 821-5029

Fax (727) 821-5029

E-mail enorisslysr@yahoo.com

Federal Number 59-3119582

Minority Small Business

Contact Enoris Sly

Parking Lot Striping Service

P.O. Box 11005
Tampa, FL 33680

Phone (813) 623-1454

Fax (813) 664-0140

E-mail lindaplss@aol.com

Federal Number 59-1522393

Minority Small Business

Contact Fernando Llop

Sunrise Utility Construction, Inc.

P.O. Box 272293
Tampa, FL 33688-2293

Phone (813) 949-3749

Fax (813) 949-0408

E-mail LMNBOSS@AOL.COM

Federal Number 59-3034012

Minority Woman

Contact Lisa Nehrboss

Tampa Bay Construction & Engineering, Inc.

10503 Palm Cove Ave
Tampa, FL 33647

Phone (813) 984-9898

Fax (813) 907-0980

E-mail aerchid@tbcei.com

Federal Number 59-3713572

Minority Small Business

Contact Ahmad Erchid

Chet Netherly, LLC d/b/a Anything in Concrete

246 W Canal Drive
Palm Harbor, FL 34684

Phone (727) 945-7035

Fax (727) 934-0568

E-mail netherlyWCAN@aol.com

Federal Number 20-3926235

Minority Small Business

Contact Chet Netherly

Velez Concrete Construction, Inc.

3926 E. Eden Roc Circle
Tampa, FL 33634

Phone (813) 493-4762

Fax (813) 882-3455

E-mail velezconcrete@verizon.net

Federal Number 83-0373603

Minority Small Business

Contact John Velez

Tagarelli Construction, Inc.

P.O. Box 681
Tarpon Springs, FL 34689

Phone (727) 937-6171

Fax (727) 937-6172

E-mail tagarelli@verizon.net

Federal Number 59-3339407

Minority Small Business

Contact Michael Tagarelli

City of Tampa MBD Office

SLBE Goal Setting Firms Report

as of 11/5/2013



CONCRETE (SIDEWALKS, DRIVEWAYS, FORM & FINISH)

Mend It Asphalt & Concrete Services, Inc.

4915 15th Avenue South
Gulfport, FL 33707

Phone (727) 327-7784

Fax (727) 327-4504

E-mail menditasphaltconcrete@yahoo.com

Federal Number 59-3274522

Minority Small Business

Contact Robert Mendez

CMK Construction, Inc.

2053 Mountain Ash Way
New Port Richey, FL 34655

Phone (727) 243-9234

Fax (727) 848-2026

E-mail manny@cmkconstructioninc.com

Federal Number 20-1609262

Minority Small Business

Contact Manuel Kavouklis

Powell Concrete, LLC

1410 Swift Ct.
Kissimmee, FL 34759

Phone (863) 438-4454

Fax (863) 496-1227

E-mail powellconcrete1@yahoo.com

Federal Number 83-0467921

Minority Small Business

Contact Earl Powell

Velocity Construction, Inc.

1320 E. 137th Ave
Tampa, FL 33613

Phone (813) 624-2117

Fax (800) 807-0314

E-mail bconnor@tampabay.rr.com

Federal Number 74-3082984

Minority Small Business

Contact William Connor

ARC Development, Inc.

5311 S. Falkenburg Rd., Ste. D-20
Tampa, FL 33619-0037

Phone (813) 952-3250

Fax (813) 952-3260

E-mail Rick@ARC-FL.com

Federal Number 20-0826206

Minority Small Business

Contact Richard Coyer

Kilgore Construction, LLC

11697 Walsingham Rd.
Largo, FL 33778

Phone (727) 755-2294

Fax (727) 581-5724

E-mail jo@kilgorellc.com

Federal Number 26-3771464

Minority Small Business

Contact Harold Kilgore

City of Tampa MBD Office

SLBE Goal Setting Firms Report

as of 11/5/2013



CONCRETE (SIDEWALKS, DRIVEWAYS, FORM & FINISH)

Tampa Bay Construction Group

12651 North Dale Mabry Hwy, Suite
272568
Tampa, FL 33688

Phone (813) 402-8827

Fax (813) 388-4554

E-mail get-it-done@mytbcgroup.com

Federal Number 26-4797153

Minority Small Business

Contact Joy Iurato

JMJ Site Development, Inc

P.O. Box 1095
Lithia, FL 33547

Phone (813) 927-2484

Fax

E-mail jmjstitedevelopment@gmail.com

Federal Number 27-3413832

Minority Small Business

Contact Jeff Joaquin

Allen Masonry & General Contracting, Inc.

6215 Travis Blvd.
Tampa, FL 33610

Phone (813) 627-9231

Fax

E-mail allenmasonrygc@gmail.com

Federal Number 20-1580292

Minority Small Business

Contact Steve Allen

SOD, SEED SOIL, AND INOCULANTS

Morelli Landscaping, Inc

4855 162nd Avenue North
Clearwater, FL 33762

Phone (727) 535-6263

Fax (727) 536-6855

E-mail vjmorelli@tampabay.rr.com

Federal Number 59-1877993

Minority Small Business

Contact Joe Morelli

Ed's Lawn & Landscaping, Inc.

P.O. Box 130744
Tampa, FL 33681

Phone (813) 254-8499

Fax (813) 250-3779

E-mail edslawn@verizon.net

Federal Number 59-3239828

Minority Small Business

Contact Susan Breit

Professional Property Services

10105 11th Street North
Tampa, FL 33612

Phone (813) 972-4057

Fax (813) 971-0882

E-mail paulrobinson22@msn.com

Federal Number 59-1341451

Minority Small Business

Contact Hyacinth Robinson

City of Tampa MBD Office

SLBE Goal Setting Firms Report

as of 11/5/2013



SOD, SEED SOIL, AND INOCULANTS

Baron's Landscaping Services, Inc.

P.O. Box 4047
Tampa, FL 33677

Phone (813) 404-1509

Fax (813) 476-6255

E-mail baronslawncare@aol.com

Federal Number 65-0837654

Minority Small Business

Contact Randy Conte

Sunbelt Sod & Grading Company

819 - 9th St. N.E.
Ruskin, FL 33570

Phone (813) 641-9855

Fax (813) 645-7263

E-mail sunbeltsod@verizon.net

Federal Number 13-4250933

Minority Small Business

Contact Lesley Silva

NPC Mowing & Landscaping

P.O. Box 292873 6441 Eureka Springs
Road
Tampa, FL 33687-2873

Phone (813) 967-4386

Fax (352) 668-3295

E-mail Jwoodho793@aol.com

Federal Number 03-0555858

Minority Small Business

Contact John Woodhouse

Fresh Start Development, Inc.

P.O. Box 310592
Tampa, FL 33680

Phone (813) 758-5345

Fax (813) 333-5949

E-mail freshstartdevelop@yahoo.com

Federal Number 20-3857845

Minority Small Business

Contact Katina McClinton

Cardinal Landscaping Services of Tampa, Inc.

817 E. Okaloosa Ave.
Tampa, FL 33604

Phone (813) 915-9696

Fax (813) 915-9695

E-mail Mike@cardinallandscape.com

Federal Number 59-3394554

Minority Small Business

Contact Mark Mantei

Gibbs Properties, LLC

17633 Gunn Hwy #236
Odessa, FL 33556

Phone (727) 376-4465

Fax (813) 425-0455

E-mail gmjservices@msn.com

Federal Number 43-2117741

Minority Small Business

Contact Bill Gibbs

City of Tampa MBD Office



SLBE Goal Setting Firms Report

as of 11/5/2013

SOD, SEED SOIL, AND INOCULANTS

Jungle Scapes

1717 E. Busch Blvd., Suite 1101
Tampa, FL 33626

Phone (813) 516-9950

Fax (813) 902-7221

E-mail info@jungle-scapes.com

Federal Number 26-2517542

Minority Small Business

Contact Hulseley Ebanks, Jr.

SLBE Contract Goal

| |
|-------|
| Goal |
| 13.9% |

Instructions Regarding Use of the SLBE Goal Setting List

Bidders must solicit a subcontracting bid from ALL of the firms listed on the SLBEs list provided on the City's web site, and provide documentation of emails, faxes, phone calls, letters, or other communication with the firms a first step in demonstrating Good-Faith Efforts to achieve the goal set for SLBE participation on this contract.

The list is formatted to facilitate e-mailing of a solicitation to the listed firms by copying and pasting the email addresses.

The SLBE participation Goal is based upon the availability of the certified firms indicated on the attached list. The Goal and Requirements of the City's Equal Business Opportunity Program are stated in the Bid/Contract Document, Specifications.



Page 1 of 2
City of Tampa
Official Letter of Intent
(Form MBD-40)

A Letter of Intent is required for each WMBE/SLBE listed on the Schedule of Subcontractors to be Utilized (MBD 20 Form). Letter of Intent must be signed by both the Bidder/Service Provider and WMBE/SLBE firm.

Bid/Proposal/Contract Number: _____

Bid/Proposal/Contract Name: _____

A. To be completed by the Bidder/Service Provider

Name of Bidder: _____

Address: _____

Contact Person: _____

Telephone: _____ Fax: _____

Email: _____

B. To be completed by WMBE/SLBE

Name of WMBE/SLBE: _____

Address: _____

Contract Person: _____

Telephone: _____ Fax: _____

Email: _____

C. Identify the scope of work to be performed or item(s) to be supplied by the WMBE/SLBE. On unit price bids, identify to which bid line item the WMBE/SLBE's work scope or supply corresponds:

D. Cost of work to be performed by WMBE/SLBE: _____

E. Cost of work to be performed by WMBE/SLBE as a percent of total City contract amount: _____

Bidder/Proposer certifies that it intends to utilize the WMBE/SLBE listed above, and that the work described above is accurate. Bidder/Proposer will provide City with copy of the related subcontract agreement and/or purchase order prior to commencement of the WMBE/SLBE's work. The WMBE/SLBE firm certifies that it has agreed to provide such work/supplies for the amount stated above.

Bidder/Proposer: _____ Date: _____

Signature and Title

WMBE/SLBE Firm: _____ Date: _____

Signature and Title



Page 2 of 2
Official Letter of Intent Instructions
City of Tampa
Equal Business Opportunity Program

The Official Letter of Intent must be submitted to the soliciting department within ten (10) work days of the bid opening, prior to award. Not providing all letters of intent within the prescribed time frame may be cause to delay award or declare the bid to be non-responsive.

Bid/Proposal/Contract Number- Please provide bid/proposal/contract number provided by City of Tampa procuring department.

Bid/Proposal/Contract Name – Please provide bid/proposal/contract name provided by City of Tampa procuring department.

To be Completed by the Bidder/Service Provide – Please provide prime contractor or main bidders detailed company information as indicated.

To be completed by the WMBE/SLBE – Please provide WMBE/SLBE subcontractor detailed company information as indicated.

Bidder is to Identify the scope of work to be performed or item(s) to be supplied by the WMBE/SLBE. On unit price bids indentify, which bid line item the WMBE/SLBE’s scope of work or supply corresponds – Please provide details of the services or supplies the WMBE/SLBE will provide.

Cost of work to be performed by WMBE/SLBE – Provide agreed upon estimate of work or supplies total price (Unit prices are accepted if specific quantities have yet to be determined).

Bidder/Proposer – Signature of authorized agent for the prime contractor or main bidder with date signed.

WMBE/SLBE firm – Signature of authorized agent for the WMBE/SLBE subcontractor or supplier with date signed.

Contract Confirmation – A copy of the executed subcontract agreement and/or purchase order with the WMBE/SLBE must be filed with the City of Tampa immediately upon execution and/or prior to commencement of work by WMBE/SLBE.

SOLICITATION FOR SUBCONTRACTOR QUOTES

From:
OUR COMPANY NAME:
TELEPHONE NUMBER:
ADDRESS:
FAX NUMBER:
E-MAIL ADDRESS:

To Subcontractor:

Our firm is in the process of preparing a bid for a **City of Tampa Contract**. Please accept this notice as our request for quotes for the scope of work identified below. Please respond to this request by filling in the information below and returning via e-mail or fax to the address or number provided. Please contact us if you need any assistance in obtaining bonding, lines of credit, insurance, assistance in obtaining necessary equipment, supplies, materials, participation in a City-sponsored mentor-protégé program, or if you have any questions.

Plans and Specs for this project are posted at:
http://www.tampagov.net/dept_contract_administration/programs_and_services/construction_project_bidding/

CONTRACT NO.:
CONTRACT NAME:
CITY'S BID OPENING DATE:
DEADLINE FOR YOUR SUBCONTRACTOR BID OR RESPONSE:
SPECIFIC SCOPE OF WORK:

Please complete and submit with your subcontract bid or response:

YOUR FIRM'S NAME:
MAILING ADDRESS:
CITY:
STATE:
ZIP:
FAX NUMBER:
E-MAIL ADDRESS:

Yes, my company is interested in quoting this project for the following items of work:

No, my company will not quote this project for the following reason(s):

(Sample Suggested Sub Solicitation 3-9-9 Tampa MBDO)

Contract 14-C-00008; Roadway Restoration - Water Department - Rebid

PROPOSAL

To the Mayor and City Council of the City of Tampa, Florida:

Name of Bidder _____

Business Phone Number and Email Address _____

Business Name and Mailing Address _____

Phone Number and Name of Contact Regarding Permits _____

Contractor/Qualifiers Name and Federal Identification Number _____

Date of Proposal _____

(If Bidder is a firm, fill in the following blanks):

Names and Residential Addresses of Partners _____

(If Bidder is a corporation, fill in the following blanks):

Organized under the laws of the State of _____

Names and Address of President _____

Name and Address of Vice President _____

Name and Address of Secretary _____

Names and Address of Treasurer _____

The above-named Bidder affirms and declares:

- (1) That the Bidder is of lawful age and that no other person, firm or corporation has any interest in this Proposal or in the Contract proposed to be entered into.
- (2) That this Proposal is made without any understanding, agreement or connection with any other person, firm, or corporation making Proposal for the same purposes, and is in all respects fair and without collusion or fraud.
- (3) That the Bidder is not in arrears to the City of Tampa, upon debt or contract, and is not a defaulter, as surety or otherwise, upon any obligation to the City of Tampa.
- (4) That no officer or employee or person whose salary is payable in whole or in part from the City Treasury is, shall be or become interested, directly or indirectly, as a contracting party, partner, stockholder, surety or otherwise, in this Proposal, or in the performance of the Contract, or in the supplies, materials, or equipment and work or labor to which it relates, or in any portion of the profits thereof.
- (5) That the Bidder has carefully examined the site of the work and that, from his own investigations, he has satisfied himself as to the nature and location of the work, the character, quality, and quantity of materials and the kinds and extent of equipment and other facilities needed for the performance of the work, the general and local conditions and all difficulties to be encountered, and all other items which may, in any way, affect the work or its performance.
- (6) That the Bidder
_____ Has; Treasury Number _____
_____ Has not
(Check applicable box)
previously performed work under the President's Executive Order Nos. 11246 and 11375.
- (7) That the undersigned, as Bidder, also declares that he has carefully examined and fully understands all the component parts of the Contract Documents and agrees that he will execute the Contract and finish the required Performance Bond and will completely perform the work in strict accordance with the terms of the Contract and the Contract Documents therein referred to for the following prices, to wit:

| Item No. | Description | Unit | Approx. Quantity | Unit Price in Words | Unit Price | Total Computed Price |
|----------|--|-------|------------------|---------------------|------------|----------------------|
| 2200 | Furnish, place, and compact lime rock base | CY | 400 | | \$ | \$ |
| 2201 | Furnish, place, and compact crushed concrete base | CY | 100 | | \$ | \$ |
| 2202 | Furnish, place, and compact ABC-3 asphalt base | CY | 50 | | \$ | \$ |
| 2203 | Furnish, place, and compact Superpave Type B-12.5 base (0-50 TN) | TN | 100 | | \$ | \$ |
| 2204 | Restore asphalt concrete surface Type S-1 (0-50 TN) | TN | 50 | | \$ | \$ |
| 2205 | Restore asphalt concrete surface Superpave Type SP12.5 (0-50 TN) | TN | 50 | | \$ | \$ |
| 2206 | Restore 6" thick concrete driveway | SY | 300 | | \$ | \$ |
| 2207 | Restore brick pavement | SY | 50 | | \$ | \$ |
| 2208 | Furnish, place and grade Type S-III asphaltic concrete overlay (0-50 TN) | TN | 400 | | \$ | \$ |
| 2209 | Furnish, place and grade Superpave Type SP-9.5 asphalt overlay (0-50 TN) | TN | 50 | | \$ | \$ |
| 2210 | Mechanical milling of asphalt roadways in 1-inch increments | SY-IN | 1,800 | | \$ | \$ |
| 2211 | Mobilization to perform milling operations | EA | 2 | | \$ | \$ |
| 2212 | Signalization loops | EA | 2 | | \$ | \$ |
| 2213 | Traffic Control Officer (off-Duty Law Enforcement) | MH | 30 | | \$ | \$ |
| 2214 | Work Zone Signs | ED | 10,000 | | \$ | \$ |
| 2215 | Business Signs | EA | 15 | | \$ | \$ |

| Item No. | Description | Unit | Approx. Quantity | Unit Price in Words | Unit Price | Total Computed Price |
|----------|--|------|------------------|---------------------|------------|----------------------|
| 2216 | Barricades (Temporary - Type II) | ED | 20,000 | | \$ | \$ |
| 2217 | Barricades (Temporary -Type II) (6") | ED | 5,000 | | \$ | \$ |
| 2218 | Advance Warning Arrow Panel | ED | 100 | | \$ | \$ |
| 2219 | High Intensity Flashing Lights (Temporary -Type B) | ED | 5,000 | | \$ | \$ |
| 2220 | Variable Message Sign (Temporary) | ED | 100 | | \$ | \$ |
| 2221 | 6" Thermoplastic Striping | LF | 100 | | \$ | \$ |
| 2222 | 8" Thermoplastic Striping | LF | 100 | | \$ | \$ |
| 2223 | 12" Thermoplastic Striping | LF | 100 | | \$ | \$ |
| | | | | | | |
| 3000 | Restore concrete Type "D" curb | LF | 150 | | \$ | \$ |
| 3001 | Restore concrete Type "F" curb | LF | 150 | | \$ | \$ |
| 3002 | Restore stone or precast curb | LF | 50 | | \$ | \$ |
| 3003 | Restore asphaltic concrete curb | LF | 50 | | \$ | \$ |
| 3004 | Restore 4" thick concrete sidewalk | SY | 440 | | \$ | \$ |
| 3005 | Detectable Warning Surface | SY | 100 | | \$ | \$ |
| 3006 | Grade and sod roadside, ditch bottoms and sides | SY | 5,000 | | \$ | \$ |
| 4000 | Emergency Mobilization Fee | EA | 10 | | \$ | \$ |

Computed Total Price In Words:

_____ dollars and _____ cents.

Computed Total Price in Figures: \$ _____

The bidder acknowledges that the following addenda have been received and that the changes covered by the addendum(s) have been taken into account in this proposal: #1 ___ #2 ___ #3 ___ #4 ___ #5 ___.

The bidder acknowledges the requirements of the City of Tampa's Equal Business Opportunity Program.

Bidder acknowledges that included in the various items of the proposal and the Total Bid Price are costs for complying with the Florida Trench Safety Act (90096), (Laws of Fla.) effective October 1, 1990. The bidder further identifies the costs to be summarized below:

| | Trench Safety Measure (Description) | Unit of Measure (LF, SY) | Unit Quantity | Unit Cost | Extended Cost |
|----|-------------------------------------|--------------------------|---------------|-----------|---------------|
| A. | _____ | _____ | _____ | _____ | _____ |
| B. | _____ | _____ | _____ | _____ | _____ |
| C. | _____ | _____ | _____ | _____ | _____ |
| D. | _____ | _____ | _____ | _____ | _____ |

Total Cost \$ _____

Signed _____

Failure to complete the above may result in the bid being declared non-responsive.

Accompanying this Proposal is a certified check, cashier's check or Bid Bond (form included herein must be used) on the form at least five (5) percent of the total amount of the Proposal which check shall become the property of the

_____ of _____
(Name of Bank or Surety) (City & State)

City of Tampa, or which bond shall become forthwith due and payable to the City of Tampa, if this Proposal shall be accepted by the City of Tampa and the undersigned shall fail to execute a contract with and to furnish the required Performance Bond and Payment Bond to the City of Tampa within twenty (20) days after the date of receipt of written Notice of Award by the City of Tampa to the undersigned so to do.

Dated _____, 2014

(Name of Bidder)

(Address of Bidder)

(Signature)

(Title)

Where Bidder is a Corporation:

Attest:

Secretary

AFFIX
CORPORATE
SEAL

(ACKNOWLEDGMENT OF PRINCIPAL)

STATE OF _____)
) SS:
COUNTY OF _____)

For a Corporation:

STATE OF _____
COUNTY OF _____

The foregoing instrument was acknowledged before me this ____ of _____, 2014 by _____ of _____, a _____ corporation, on behalf of the corporation. He/she is ____ personally known or has ____ produced _____ as identification.

Notary

My Commission Expires:

For an Individual:

STATE OF _____
COUNTY OF _____

The foregoing instrument was acknowledged before me this ____ of _____, 2014 by _____ who is ____ personally known to me or has ____ produced _____ as identification.

Notary

My Commission Expires:

For a Firm:

STATE OF _____
COUNTY OF _____

The foregoing instrument was acknowledged before me this ____ of _____, 2014 by _____ who signed on behalf of the said firm. He/she is ____ personally known or has ____ produced _____ as identification.

Notary

My Commission Expires:

Good Faith Effort Compliance Plan for Small Local Business Subcontracting
City of Tampa - Equal Business Opportunity Program

Contract _____ Bid Date _____

Bidder _____

Signature _____ Date _____

Name _____ Title _____

The following Compliance Plan is a true report of Good Faith Efforts made to accomplish subcontracting goals for Small Local Business Enterprises, SLBEs, on the referenced contract:

- The goal for SLBE participation has been met or exceeded. See the DMI form reporting subcontractors to be utilized.**
(Check Box, if appropriate; the remainder of the Compliance Plan need not be reported.)
- The goal for SLBE participation has not been met. The following is a recap of Good Faith Efforts made:**
(Check applicable boxes below. Enclose additional documents, and/or add remarks below as needed.)
 - (1) Soliciting through reasonable and available means the interest of SLBEs that have the capability to perform the work of the contract. The Bidder or Contractor must solicit this interest within sufficient time to allow the SLBEs to respond. The Bidder or Contractor must take appropriate steps to follow up initial solicitations with interested SLBEs. See DMI report forms for subcontractors solicited. See enclosed supplemental data on solicitation efforts. Remarks:
 - (2) Providing interested SLBEs with adequate information about the plans, specifications, and requirements of the contract, including addenda, in a timely manner to assist them in responding to the solicitation. See enclosed sample solicitation. Remarks:
 - (3) Negotiating in good faith with interested SLBEs that have submitted bids. Documentation of negotiation must include the names, addresses, and telephone numbers of SLBEs that were solicited; the date of each such solicitation; a description of the information provided regarding the plans and specifications for the work selected for subcontracting; and evidence as to why agreements could not be reached with SLBEs to perform the work. That there may be some additional costs involved in soliciting and using SLBEs is not a sufficient reason for a contractor's failure to meet the goals, as long as such costs are reasonable. Bidders are not required to accept higher quotes in order to meet the goal. DMI subcontractor-utilized forms reflect successful negotiations This project is of a low-bid nature and negotiations are limited to clarifications of scope and specifications. See enclosed document. Remarks:
 - (4) Not rejecting SLBEs as being unqualified without sound reasons based on a thorough investigation of their capabilities. The SLBEs standing within its industry, membership in specific groups, organizations, or associations and political or social affiliations are not legitimate causes for rejecting or not soliciting bids to meet the goals. Not applicable. See attached explanation for rejection of a low-bidding subcontractor's bid. Remarks:
 - (5) Making a portion of the work available to SLBE subcontractors and suppliers and to select those portions of the work or material consistent with the available SLBE subcontractors and suppliers, so as to facilitate meeting the goal. Sub-Contractors were allowed to bid on their own choice of work or trade without restriction to a pre-determined portion. See enclosed comments. Remarks:
 - (6) Making good faith efforts, despite the ability or desire of a Bidder or Contractor to perform the work of a contract with its own organization. A Bidder or Contractor who desires to self-perform the work of a contract must demonstrate good faith efforts unless the goal has been met. Sub-Contractors were not prohibited from submitting bids on work not usually sub-contracted. Remarks:
 - (7) Selecting portions of the work to be performed by SLBEs in order to increase the likelihood that the goals will be met. This includes, where appropriate, breaking out contract work items into economically feasible units to facilitate SLBE participation, even when the Bidder or Contractor might otherwise prefer to perform these work items with its own forces. Sub-Contractors were allowed to bid on their own choice of work or trade without restriction to a pre-determined portion. Sub-Contractors were not prohibited from submitting bids on work not usually sub-contracted. See enclosed comments. Remarks:
 - (8) Making efforts to assist interested SLBEs in obtaining bonding, lines of credit, or insurance as required by the city or contractor. See enclosed sample solicitation see enclosed document. Remarks:
 - (9) Making efforts to assist interested SLBEs in obtaining necessary equipment, supplies, materials, or related assistance or services, including participation in a City-sponsored mentor-protégé program. See enclosed sample solicitation. See enclosed document. Remarks:
 - (10) Effectively using the services of the City and other organizations that provide assistance in the recruitment and placement of SLBEs. See enclosed document. The following services were used:

Other Supporting Good Faith Efforts: See enclosed document. Remarks:

Compliance Plan: Guidance For Meeting Good Faith Efforts

1. All firms on the SLBE Goal Setting List must be solicited and documentation provided for email, fax, letters, phone calls, and other communication with the listed firms. The DMI Solicited and DMI-Utilized forms must be completed for all firms solicited or utilized. Other opportunities for subcontracting may be explored by consulting the City of Tampa and/or Hillsborough County certification listings of SLBE's.
2. Solicitation of SLBEs, via written or electronic notification, should provide specific information on the services needed, where plans can be reviewed and assistance offered in obtaining these, if required. Solicitations should be typically be sent a week or more before the bid date. Sample copies of the bidder's solicitations should be provided.
3. With any quotes received, a follow-up should be made whenever needed to confirm scope of work. For any SLBE low quotes rejected, an explanation should be provided detailing negotiation efforts.
4. If a low bid SLBE is rejected or deemed unqualified the contractor must provide an explanation and supporting documentation for this decision.
5. Prime should break down portions of work into economical feasible opportunities for subcontracting. The SLBE directory can be useful in identifying additional subcontracting opportunities and firms not listed in the "SLBE Goal Setting Firms List."
6. Contractor should not preclude SLBEs from bidding on any part of work, even if the Contractor can self-perform the work.
7. Contractor should avoid relying solely on subcontracting out work where availability is not sufficient to attain pre-determined goal.
8. In its solicitations, the Bidder should offer assistance to SLBEs in obtaining bonding, insurance, etc, if required of subcontractors by the City or Prime Contractor.
9. In its solicitation, the Bidder should offer assistance in obtaining equipment for a specific job to SLBEs, if needed.
10. Contractor should use the services offered by such agencies as the Minority Business Development Office of the City of Tampa, Hillsborough County and the NAACP Empowerment Center for the recruitment and placement of SLBEs.



Instructions for completing The Sub-(Contractors/Consultants/ Suppliers) Solicited Form (Form MBD-10)

This form must be submitted with all bids or proposals. All subcontractors (regardless of ownership or size) solicited and subcontractors from whom unsolicited quotations were received must be included on this form. The instructions that follow correspond to the headings on the form required to be completed. Note: Ability or desire to self-perform all work shall not exempt the prime from Good Faith Efforts when Goal has been established.

- **Contract No.** This is the number assigned by the City of Tampa for the bid or proposal.
- **Contract Name.** This is the name of the contract assigned by the City of Tampa for the bid or proposal.
- **Contractor Name.** The name of your business.
- **Address.** The physical address of your business.
- **Federal ID.FIN.** A number assigned to your business for tax reporting purposes.
- **Phone.** Telephone number to contact business.
- **Fax.** Fax number for business.
- **Email.** Provide email address for electronic correspondence.
- **No Firms were contacted/solicited for this contract.** Checking the box indicates that a pre-determined Subcontract Goal was not set by the City resulting in your business not using subcontractors and will self-perform all work. If during the performance of the contract you employ subcontractors, the City must pre-approve subcontractors. Use of the “Sub-(Contractors/Consultants/Suppliers) Payments” form must be submitted with your invoices. Note: Certified SLBE or WMBE firms bidding as Primes are not exempt from outreach and solicitation of subcontractors.
- **No Firms were contacted because.** Provide brief explanation why no firms were contacted/solicited.
- **See attached documents.** Check box, if after you have completed the DMI Form in its entirety, you are providing any additional documentation relating to the form. All DMI data not submitted on the MBD Form-10 must be in the same format and have all requested data from MBD Form-10 included.

The following instructions are for information of any and all subcontractors solicited.

- **“S” = SLBE, “W” = WMBE.** Enter “S” for firms Certified by the City as Small Local Business Enterprises and/or “W” for firms Certified by the City as Women/Minority Business Enterprise.
- **Federal ID.FIN.** A number assigned to a business for tax reporting purposes. This information is critical in proper identification of the subcontractor.
- **Company Name, Address, Phone & Fax.** Provide company information for verification of payments.
- **Type of Ownership.** Indicate the Ethnicity and Gender of the owner of the subcontracting business.
- **Trade, Services, or Materials** Indicate the trade, service, or material provided by the subcontractor. NIGP codes are listed at top section of document.
- **Contact Method L=letter, F=fax, E=Email, P=Phone.** Indicate with letter the method of soliciting for bid.
- **Quote or Resp. (response) Rec’d (received) Y/N.** Indicate “Y” Yes if you received a quotation or if you received a response to your solicitation. Indicate “N” No if you received no response to your solicitation from the subcontractor.

If any additional information is required or you have any questions, you may call the Minority Business Development Office at (813) 274-5522.



Page 4 of 4DMI – Solicited/Utilized

Instructions for completing **The Sub-(Contractors/Consultants/ Suppliers) to be Utilized Form (Form MBD-20)**

This form must be submitted with all bids or proposals. All subcontractors projected to be utilized must be included on this form.

- **Contract No.** This is the number assigned by the City of Tampa for the bid or proposal.
- **Contract Name.** This is the name of the contract assigned by the City of Tampa for the bid or proposal.
- **Contractor Name.** The name of your business.
- **Address.** The physical address of your business.
- **Federal ID.FIN.** A number assigned to your business for tax reporting purposes.
- **Phone.** Telephone number to contact business.
- **Fax.** Fax number for business.
- **Email.** Provide email address for electronic correspondence.
- **No Subcontracting (of any kind) will be performed on this contract.** Checking box indicates your business will not use subcontractors when no Subcontract Goal has been set by the City, but will self-perform all work. When subcontractors are utilized during the performance of the contract, the “Sub-(Contractors/Consultants/Suppliers) Payments” form must be submitted with your invoices. Note: Certified SLBE or WMBE firms bidding as Primes are not exempt from outreach and solicitation of subcontractors.
- **See attached documents.** Check if you have provided any additional documentation relating to the utilization of subcontractors.
-

The following instructions are for information of Any and All subcontractors to be utilized.

- **Federal ID.FIN.** A number assigned to a business for tax reporting purposes. This information is critical in proper identification of the subcontractor.
- **“S” = SLBE, “W” = WMBE.** Enter “S” for firms Certified by the City as Small Local Business Enterprises and/or “W” for firms Certified by the City as Women/Minority Business Enterprise.
- **Company Name, Address, Phone & Fax.** Provide company information for verification of payments.
- **Type of Ownership.** Indicate the Ethnicity and Gender of the owner of the subcontracting business.
- **Trade, Services, or Materials (NIGP code if Known)** Indicate the trade, service, or material provided by the subcontractor. NIGP codes are available at <http://www.tampagov.net/mbd>.
- **Amount of Quote, Letters of Intent** (required for both SLBEs and WMBEs)
- **Percent of Work/Contract.** Indicate the percent of the total contract price the subcontract(s) represent.
- **Total Subcontract/Supplier Utilization.** – Provide total dollar amount of all subcontractors/suppliers projected to be used for the contract. (Dollar amounts may not apply to CCNA proposals.)
- **Total SLBE Utilization.** Provide total dollar amount for all projected SLBE subcontractors/Suppliers used for this contract. (Dollar amounts may not apply to CCNA proposals.)
- **Total WMBE Utilization.** Provide total dollar amount for all projected WMBE subcontractors/Suppliers used for this contract. (Dollar amounts may not apply to CCNA proposals.)
- **Percent SLBE Utilization.** Total amount allocated to SLBEs divided by the total bid amount. (Dollar amounts may not apply to CCNA proposals.)
- **Percent WMBE Utilization.** Total amount allocated to WMBEs divided by the total bid/proposal amount. (Dollar amounts may not apply to CCNA proposals.)

If any additional information is required or you have any questions, you may call the Minority Business Development Office at (813) 274-5522.

TAMPA BID BOND
Contract 14-C-00008; Roadway Restoration - Water Department - Rebid

KNOW ALL MEN BY THESE PRESENTS, that we, _____

_____ (hereinafter called the Principal) and _____

(hereinafter called the Surety) a Corporation chartered and existing under the laws of the State of _____, with its principal offices in the City of _____, and authorized to do business in the State of Florida, are held and firmly bound unto the City of Tampa, a Municipal Corporation of Hillsborough County, Florida, in the full and just sum of 5% of the amount of the (Bid) (Proposal) good and lawful money of the United States of America, to be paid upon demand of the City of Tampa, Florida, to which payment will and truly be made we bind ourselves, our heirs, executors, administrators, successors, and assigns, jointly and severally and firmly these presents.

WHEREAS, the Principal is about to submit, or has submitted to the City of Tampa, Florida, a Proposal for the construction of certain facilities for the City designated Contract 14-C-00008, Roadway Restoration - Water Department - Rebid.

WHEREAS, the Principal desires to file this Bond in accordance with law, in lieu of a certified Bidder's check otherwise required to accompany this Proposal.

NOW, THEREFORE: The conditions of this obligation are such that if the Proposal be accepted, the Principal shall, within twenty (20) days after the date of receipt of written Notice of Award, execute a contract in accordance with the Proposal and upon the terms, conditions and price set forth therein, in the form and manner required by the City of Tampa, Florida and execute a sufficient and satisfactory Performance Bond and Payment Bond payable to the City of Tampa, Florida in an amount of one hundred percent (100%) of the total contract price, in form and with security satisfactory to said City, then this Bid Bond obligation is to be void; otherwise to be and remain in full force and virtue in law, and the Surety shall, upon failure of the Principal to comply with any or all of the foregoing requirements within the time specified above, immediately pay to the aforesaid City, upon demand, the amount thereof, in good and lawful money of the United States of America, not as a penalty, but as liquidated damages.

IN TESTIMONY THEREOF, the Principal and Surety have caused these presents to be duly signed and sealed this _____ day of _____, 2014.

Principal _____

BY _____

TITLE _____

BY _____

TITLE _____

Countersigned:
(SEAL)

Local Resident Producing Agent

Local Resident Producing Agent's Address

Name of Local Agency

The addition of such phrases as "not to exceed" or like import shall render the (Bid) (Proposal) non-responsive.

AGREEMENT

For furnishing all labor, materials and equipment, together with all work incidental thereto, necessary and required for the performance of the work for the construction of Contract 14-C-00008 in accordance with your Proposal dated _____, amounting to a total of \$ _____ as completed in accordance with subsections I-2.09 and I-2.10 of the Instruction to Bidders.

THIS AGREEMENT, made and entered into in triplicate, this ____ day of _____, 2014, between the City of Tampa, Florida, hereinafter called the City, and hereinafter called the Contractor.

WITNESSETH that, in consideration of the mutual stipulations, agreements, and covenants herein contained, the parties hereto have agreed and hereby agree with each other, the Party of the First Part for itself, its successors and assigns, and the Party of the Second Part for itself, or himself, or themselves, and its successors and assigns, or his or their executors, administrators and assigns, as follows:

Contract 14-C-00008; Roadway Restoration - Water Department - Rebid, shall include, but not be limited to, construction of various roadway restoration improvements including street resurfacing, driveway repair, sidewalk construction, other associated surface restoration with all associated work required for a complete project in accordance with the Contract Documents.

Contract Documents referred to in Article 1.01 of this Agreement also includes this volume, applicable standard drawings, the plans and any provisions referred to whether actually attached or not.

TAMPA AGREEMENT

SECTION 1 GENERAL

ARTICLE 1.01 THE CONTRACT

Except for titles, subtitles, headings, running headlines, and tables of contents (all of which are printed herein merely for convenience), the following, except for such portions thereof as may be specifically excluded, constitute the Contract:

The Notice to Bidders;
The Instructions to Bidders, including Special Instructions and General Instructions;
The Proposal;
The Bid Bond;
The Certification of Nonsegregated Facilities;
The Notice of Award;
The Agreement;
The Performance Bond;
The Notice To Proceed;
The Specifications, including the General Provisions, the Workmanship and Materials, the Specific Provisions or the Contract Items
The Plans;
All Supplementary Drawings Issued after award of the Contract;
All Addenda issued by the City prior to the receipt of proposals;
All provisions required by law to be inserted in this Contract, whether actually inserted or not.

ARTICLE 1.02 DEFINITIONS

The following words and terms, or pronouns used in their stead, shall, wherever they appear in this Contract, be construed as follows, unless different meaning is clear from the context:

(a)"City" shall mean the City of Tampa, Florida, represented by its Mayor and City Council, Party of the First Part, or such other City official as shall be duly empowered to act for the City on matters relating to this Contract.

(b)"Contractor" shall mean the Party of the Second Part hereto, whether corporation, firm or individual, or any combination thereof, and its, their, or his successors, personal representatives, executors, administrators, and assigns, and any person, firm or corporation who or which shall at any time be substituted in the place of the Party of the Second Part under this Contract.

(c)"Engineer" shall mean the Director of the Department or his duly authorized representative.

(d)"Consultant" shall mean the engineering or architectural firm or individual employed by the City to consult with and advise the City in the construction of the project.

(e)"Surety" shall mean any person, firm or corporation that has executed as Surety the Contractor's Performance Bond securing the performance of this Contract.

(f)"The Work" shall mean everything expressly or implied required to be furnished and done by the Contractor under the Contract, and shall include both Contract Work

and Extra Work.

(g)"Contract Work" shall mean everything expressly or implied required to be furnished and done by the Contractor by any one or more of the Contract parts referred to in Article 1.01 hereof, except Extra Work, as hereinafter defined; it being understood that, in case of any inconsistency in or between any part or parts of this Contract, the Engineer shall determine which shall prevail.

(h)"Contract" or "Contract Documents" shall mean each of the various part of the Contract referred to in Article 1.01 hereof, both as a whole and severally.

(i)"Extra Work" shall mean work other than that required either expressly or implied by the contract in its present form.

(j)"Plans" shall mean only those drawings specifically referred to as such in these documents, or in any Addendum. Drawings issued after the execution of the Contract to explain further, or to illustrate, or to show changes in the work, will be known as "Supplementary Drawings" and shall be binding upon the Contractor with the same force as the Plans.

(k)"Specifications" shall mean all of the directions, requirements, and standards of performance applying to the work, as hereinafter detailed and designated as such, or which may be issued in an addendum.

(l)"Addendum or Addenda" shall mean the additional contract provisions issued in writing prior to the receipt of bids.

(m)"Notice" shall mean written notice. Notice shall be served upon the Contractor, either personally or by leaving the said notice at his residence or with any employee found on the work, or addressed to the Contractor at the residence or place of business given in his proposal and deposited in a postpaid wrapper in any post office box regularly maintained by the United States Post Office.

(n)"Project" shall mean the entire improvement package or related work. The "project" may consist of several different, but related, contracts.

(o)"Site" shall mean, and be limited to, the area upon or in which the Contractor's operations are carried on and such other appropriate areas as may be designed as such by the Engineer.

(p)"Subcontractor" shall mean any person, firm, or corporation, other than employees of the Contractor, who or which contracts with the Contractor to furnish, or actually furnishes labor, or labor and materials, or labor and equipment or labor, materials, and equipment at the site.

(q)Whenever in the Contract the words "directed", "required", "permitted", "ordered", "designated", "prescribed", and words of like import are used, they shall imply the direction, requirement, permission, order, designation, or prescription of the Engineer; and "approved", "acceptable", "satisfactory", "in the judgement of", and words of like import shall mean approved by, or acceptable to, or satisfactory to, or in the judgment of the Engineer.

(r)Whenever in the Contract the word "day" is used, it shall mean calendar day.

(s)"Final Acceptance" shall mean acceptance of the

work as evidenced by an official resolution of the City. Such acceptance shall be deemed to have taken place only if and when an approving resolution has been adopted by the City Council. The final acceptance shall be signed only after the City has assured itself by tests, inspection, or otherwise, that all of the provisions of the Contract have been carried out to its satisfaction.

(t)"Eastern Standard Time" shall be construed as the time being observed in the City on the day proposals are received or other documents issued or signed.

SECTION 2 POWERS OF THE CITY'S REPRESENTATIVES

ARTICLE 2.01 THE ENGINEER

It is covenanted and agreed that the Engineer, in addition to those matters elsewhere herein expressly made subject to his determination, direction, or approval, shall have the power, subject to such express provisions and limitations herein contained as are not in conflict herewith, and subject to review by the Mayor and City Council:

(a)To monitor the performance of the work.

(b)To determine the amount, kind, quality, sequence, and location of the work to be paid for hereunder and, when completed, to measure such work for payment.

(c)To determine all questions of an engineering character in relation to the work, to interpret the Plans, Specifications and Addenda.

(d)To determine how the work of this Contract shall be coordinated with the work of other contractors engaged simultaneously on this project.

(e)To make minor changes in the work as he deems necessary, provided such changes do not result in a net increase in the cost to the City or to the Contractor of the work to be done under the Contract.

(f)To amplify the Plans, add explanatory information and furnish additional Specifications and Drawings consistent with the intent of the Contract Documents.

The power of the Engineer shall not be limited to the foregoing enumeration, for it is the intent of this Contract that all of the work shall be subject to his determinations and approval, except where the determination or approval of someone other than the Engineer is expressly called for herein and except as subject to review by the Mayor and City Council. All orders of the Engineer requiring the Contractor to perform work as Contract work shall be promptly obeyed by the Contractor.

The Engineer shall not, however, have the power to issue an extra work order, and the performance of such work on the order of the Engineer without previously obtaining written confirmation thereof from the Mayor in accordance with Article 7.02 hereof may constitute a waiver of any right to extra compensation therefor. The Contractor is warned that the Engineer has no power to change the terms and provisions of this Contract, except minor changes where such change results in no net increase in the Contract Price.

ARTICLE 2.02 DIRECTOR

The Director of the Department in addition to those matters

expressly made subject to his determination, direction or approval in his capacity as "Engineer", shall also have the power:

(a)To review any and all questions in relation to this Contract and its performance, except as herein otherwise specifically provided, and his determination upon such review shall be final and conclusive upon the Contractor.

(b)With the approval of the Mayor and City Council to authorize modifications or changes in the Contract so as to require: (1) the performance of extra work, or (2) the omission of Contract work whenever he deems it in the interest of the City to do so, or both.

(c)To suspend the whole or any part of the work whenever, in his judgment, such suspension is required: (1) in the interest of the City generally, or (2) to coordinate the work of the various Contractors engaged on this project, or (3) to expedite the completion of the entire project, even though the completion of this particular Contract may be thereby delayed, without compensation to the Contractor for such suspension other than extending the time for the completion of the work, as much as it may have been, in the opinion of the City, delayed by such a suspension.

(d)If, before the final acceptance of all the work contemplated herein, it shall be deemed necessary to take over, use, occupy, or operate any part of the completed or partly completed work, the Engineer shall have the right to do so and the Contractor will not, in any way, interfere with or object to the use, occupation, or operation of such work by the City after receipt of notice in writing from the Engineer that such work or part thereof will be used by the City on and after the date specified in such notice. Such taking over, use, occupancy or operation of any part of the completed or partially completed work shall not constitute final acceptance or approval of any such part of the work.

ARTICLE 2.03 NO ESTOPPEL

The City shall not, nor shall any department, officer, agent, or employee thereof, be bound, precluded, or estopped by any determination, decision, acceptance, return, certificate, or payment made or given under or in connection with this Contract by any officer, agent or employee of the City at any time either before or after final completion and acceptance of the work and payment therefor: (a) from showing the true and correct classification, amount, quality, or character of the work done, or that any determination, decision, acceptance, return certificate or payment is untrue, incorrect or improperly made in any particular, or that the work or any part thereof does not in fact conform to the requirements of the Contract Documents, and (b) from demanding and recovering from the Contractor any overpayments made to him or such damages as it may sustain by reason his failure to comply with the requirements of the Contract of Documents, or both.

ARTICLE 2.04 NO WAIVER OF RIGHTS

Neither the inspection, nor any order, measurements or certificate of the City or its employees, officers, or agents, nor by any order of the City for payment of money, nor any money, nor payments for or acceptance of the whole or any part of the work by the City, nor any extension of time, nor any changes in the Contract, Specifications or Plans, nor any possession by the City or its employees shall operate as a

waiver of any provisions of this Contract, nor any power herein provided nor shall any waiver of any breach of this Contract be held as a waiver of any other subsequent breach.

Any remedy provided in this Contract shall be taken and construed as cumulative, namely, in addition to each and every other suit, action, or legal proceeding. The City shall be entitled as of right to an injunction against any breach of the provisions of this Contract.

SECTION 3 PERFORMANCE OF WORK

ARTICLE 3.01 CONTRACTOR'S RESPONSIBILITY

The Contractor shall do all the work and furnish, at his own cost and expense, all labor, materials, equipment, and other facilities, except as herein otherwise provided, as may be necessary and proper for performing and completing the work under this Contract. The Contractor shall be responsible for the entire work until completed and finally accepted by the City.

The work shall be performed in accordance with the true intent and meaning of the Contract Documents. Unless otherwise expressly provided, the work must be performed in accordance with the best modern practice, with materials as specified and workmanship of the highest quality, all as determined by and entirely to the satisfaction of the Engineer.

Unless otherwise expressly provided, the means and methods of construction shall be such as the Contractor may choose, subject, however, to the approval of the Engineer. Only adequate and safe procedure, methods, structures and equipment shall be used. The Engineer's approval or the Engineer's failure to exercise his right thereon shall not relieve the Contractor of obligations to accomplish the result intended by the Contract, nor shall such create a cause of action for damages.

ARTICLE 3.02 COMPLIANCE WITH LAWS

The Contractor must comply with all local, State and Federal laws, rules, ordinances and regulations applicable to this Contract and to the work done hereunder, and must obtain, at his own expense, all permits, licenses or other authorization necessary for the prosecution of the work.

No work shall be performed under this Contract on Sundays, legal holidays or after regular working hours without the express permission of the Engineer. Where such permission is granted, the Engineer may require that such work be performed without additional expense to the City.

ARTICLE 3.03 INSPECTION

During the progress of the work and up to the date of final acceptance, the Contractor shall, at all times, afford the representatives of the City, the Florida Department of Environmental Regulation, and if applicable, the Federal Environmental Protection Agency and the Federal Department of Labor every reasonable, safe and proper facility for inspecting the work done or being done at the

site. The inspection of any work shall not relieve the Contractor of any of his obligations to perform proper and satisfactory work as herein specified. Finished or unfinished work found not to be in strict accordance with the Contract shall be replaced as directed by the Engineer, even though such work may have been previously approved and payment made therefor.

The City shall have the right to reject materials and workmanship which are defective or require their correction. Rejected work and materials must be promptly removed from the site, which must at all times be kept in a reasonably clean and neat condition.

Failure or neglect on the part of the City to condemn or reject bad or inferior work or materials shall not be construed to imply an acceptance of such work or materials, if it becomes evident at any time prior to the final acceptance of the work by the City. Neither shall it be construed as barring the City at any subsequent time from the recovery of damages of such a sum of money as may be needed to build anew all portions of the work in which inferior work or improper materials were used, wherever found.

Should it be considered necessary or advisable by the City at any time before final acceptance of the entire work to make examinations of work already completed, by removing or tearing out all or portions of such work, the Contractor shall, on request, promptly furnish all necessary facilities, labor, and material for that purpose. If such work is found to be defective in any material respect, due to the fault of the Contractor or his subcontractors, he shall defray all expenses of such examination and of satisfactory reconstruction. If, however, such work is found to meet the requirements of the Contract, the cost of examination and restoration of the work shall be considered an item of extra work to be paid for in accordance with the provisions of Article 7.02 hereof.

ARTICLE 3.04 PROTECTION

During performance and until final acceptance, the Contractor shall be under an absolute obligation to protect the finished and unfinished work against any damage, loss, or injury. The Contractor shall take proper precaution to protect the finished work from loss or damage, pending completion and the final acceptance of all the work included in the entire Contract, provided that such precaution shall not relieve the Contractor from any and all liability and responsibility for loss or damage to the work occurring before final acceptance by the City. Such loss or damage shall be at the risk of and borne by the Contractor, whether arising from acts or omissions of the Contractor or others. In the event of any such loss or damage, the Contractor shall forthwith repair, replace, and make good the work without extension of time therefor, except as may be otherwise provided herein.

The provisions of this Article shall not be deemed to create any new right of action in favor of third parties against the Contractor or the City.

ARTICLE 3.05 PRESERVATION OF PROPERTY

The Contractor shall preserve from damage all property along the line of the work, or which is in the vicinity of or is in anywise affected by the work, the removal or destruction of which is not called for by the Plans. This applies, but is not limited, to the public utilities, trees, lawn areas, building monuments, fences, pipe and underground structures, public streets (except natural wear and tear of streets resulting from legitimate use thereof by the Contractor), and wherever such property is damaged due to the activities of the Contractor, it shall be immediately restored to its original condition by the Contractor and at his own expense.

In case of failure on the part of the Contractor to restore such property, or make good such damage or injury, the City may, upon forty-eight (48) hour written notice, proceed to repair, rebuild, or otherwise restore such property as may be deemed necessary, and the cost thereof will be deducted from any monies due or which may become due the Contractor under this Contract. Nothing in this clause shall prevent the Contractor from receiving proper compensation for the removal, damage, or replacement of any public or private property not shown on the Plans, when this is made necessary by alteration of grade or alignment authorized by the Engineer, provided that such property has not been damaged through fault of the Contractor, his employees or agents.

ARTICLE 3.06 BOUNDARIES

The Contractor shall confine his equipment, apparatus, the storage of materials, supplies and apparatus of his workmen to the limits indicated on the plans, by law, ordinances, permits or direction of the Engineer.

ARTICLE 3.07 SAFETY AND HEALTH REGULATIONS

The Contractor shall comply with the Department of Labor Safety and Health Regulations for construction promulgated under the Occupational Safety and Health Act of 1970 (PL 91- 596) and under Section 107 of the Contract Work Hours and Safety Standards Act (PL91-54).

ARTICLE 3.08 TAXES

All taxes of any kind and character payable on account of the work done and materials furnished under this Contract shall be paid by the Contractor and shall be deemed to have been included in his bid. The laws of the State of Florida provide that sales and use taxes are payable by the Contractor upon the tangible personal property incorporated in the work and such taxes shall be paid by the Contractor and shall be deemed to have been included in his bid.

ARTICLE 3.09 ENVIRONMENTAL CONSIDERATIONS

The Contractor, in the performance of the work under this Contract, shall comply with all Local, State and Federal laws, statutes, ordinances, rules and regulations applicable to protection of the environment; and, in the event he violates any of the provisions of same, he shall be answerable to the Local, State and Federal agencies designated by law to protect the environment. In the event the City receives, from any of the environmental agencies, a citation which is occasioned by an act or omission of the Contractor or his

subcontractor or any officers, employees or agents of either, it is understood and agreed that the Contractor shall automatically become a party-respondent under said citation; and the City immediately shall notify the Contractor and provide him with a copy of said citation.

The Contractor shall comply with the requirements of the citation and correct the offending condition(s) within the time stated in said citation and further shall be held fully responsible for all fines and/or penalties.

**SECTION 4
TIME PROVISIONS**

ARTICLE 4.01 TIME OF START AND COMPLETION

The Contractor must commence work within thirty (30) days subsequent to the date of the receipt of the "Notice to Proceed" by the City unless otherwise provided in the Specific Provisions and Special Instructions. Time being of the essence of this Contract, the Contractor shall thereafter prosecute the work diligently, using such means and methods of construction as well as secure its full completion in accordance with the requirements of the Contract Documents no later than the date specified therefor, or on the date to which the time for completion may be extended.

The Contractor must complete the work covered by this Contract in the number of consecutive calendar days set forth in the Instructions to Bidders, unless the date of completion is extended pursuant to the provisions of Article 4.05 hereof.

The period for performance shall start from the date of signing of this Agreement by the City.

The actual date of completion will be established after a final inspection as provided in Article 4.07 hereof.

ARTICLE 4.02 PROGRESS SCHEDULE

To enable the work to be laid out and prosecuted in an orderly and expeditious manner, the Contractor shall submit to the Engineer a proposed progress schedule within fifteen (15) days after the award of this Contract.

The schedule shall state the Contract starting date, time for completion and date of completion and shall show the anticipated time of starting and completion of each of the various operations to be performed under this Contract, together with all necessary and appropriate information regarding sequence and correlation of work and an estimated time required for the delivery of all materials and equipment required for the work. The proposed schedule shall be revised as directed by the Engineer until finally approved by him, and, after such approval, shall be strictly adhered to by the Contractor. The approved progress schedule may be changed only with the written permission of the Engineer.

If the Contractor shall fail to adhere to the approved progress schedule or the schedule as revised, he shall promptly adopt such other or additional means and methods of construction as will make up for the time lost, and will assure completion in accordance with the contract time.

ARTICLE 4.03 APPROVAL REQUESTS

From time to time, as the work progresses and in the sequence indicated by the approved schedule, the Contractor must submit to the Engineer a specific request, in writing, for each item of information or approval required of him by the Contract. These requests must be submitted sufficiently in advance of the date upon which the information or approval is actually required by the Contractor to allow for the time the Engineer may take to act upon such submissions or resubmissions. The Contractor shall not have any right to an extension of time on account of delays due to his failure to submit his requests for the required information or the required approval in accordance with these requirements.

ARTICLE 4.04 COORDINATION WITH OTHER CONTRACTORS

During progress of the work, other Contractors may be engaged in performing other work on this project or on other projects on the site. In that event, the Contractor shall coordinate the work to be done hereunder with the work of such other Contractors in such manner as the Engineer may direct.

ARTICLE 4.05 EXTENSION OF TIME

If such an application is made, the Contractor shall be entitled to an extension of time for delay in completion of the work should the Contractor be obstructed or delayed in the commencement, prosecution or completion of any part of said work by any act or delay of the City, or by acts or omissions of other Contractors on this project, or by a riot, insurrection, war, pestilence, acts of public authorities, fire, lightning, hurricanes, earthquakes, tornadoes, floods, extremely abnormal and excessive inclement weather as indicated by the records of the local weather bureau for a five-year period preceding the date of the Contract, or by strikes, or other causes, which causes of delay mentioned in this Article, in the opinion of the City, are entirely beyond the expectation and control of the Contractor.

The Contractor shall, however, be entitled to an extension of time for such causes only for the number of days of delay which the City may determine to be due solely to such causes and only to the extent that such occurrences actually delay the completion of the project and then only if the Contractor shall have strictly complied with all of the requirements of Articles 4.01, 4.02, 4.03 and 4.04 hereof. It is hereby understood that the determination by the Engineer as to the order and sequence of the work shall not in itself constitute a basis for extension of time.

The determination made by the City on an application for an extension of time shall be binding and conclusive on the Contractor.

Delays caused by failure of the Contractor's materialmen, manufacturers, and dealers to furnish approved working drawings, materials, fixtures, equipment, appliances, or other fittings on time or failure of subcontractors to perform their work shall not constitute a basis of extension of time.

The Contractor agrees to make no claim for damages for delay in the performance of this Contract occasioned by any

act or omission to act of the City or any of its representatives or because of any injunction which may be brought against the City or its representatives and agrees that any such claim shall be fully compensated for by an extension of time to complete performance of the work as provided herein.

ARTICLE 4.06 LIQUIDATED DAMAGES

It is mutually agreed between the parties that time is the essence of this Contract and that there will be on the part of the City considerable monetary damage in the event the Contractor should fail to complete the work within the time fixed for completion in the Contract or within the time to which such completion may have been extended.

The amount per day set forth in the Instructions to Bidders is hereby agreed upon as the liquidated damages for each and every calendar day that the time consumed in completing the work under this Contract exceeds the time allowed.

This amount shall, in no event, be considered as a penalty or otherwise than as the liquidated and adjusted damages to the City because of the delay and the Contractor and his Surety agree that the stated sum per day for each such day of delay shall be deducted and retained out of the monies which may become due hereunder and if not so deductible, the Contractor and his Surety shall be liable therefor.

ARTICLE 4.07 FINAL INSPECTION

When the work has been completed in accordance with the requirements of the Contract and final cleaning up performed, a date for final inspection of the work by the Engineer shall be set by the Contractor in a written request therefor, which date shall be not less than ten (10) days after the date of such request. The work will be deemed complete as of the date so set by the Contractor if, upon such inspection, the Engineer determines that no further work remains to be done at the site.

If such inspection reveals interms of work still to be performed, however, the Contractor shall promptly perform them and then request a reinspection. If, upon such inspection, the Engineer determines that the work is complete, the date of final completion shall be deemed to be the last day of such reinspection.

**SECTION 5
SUBCONTRACTS AND ASSIGNMENTS**

ARTICLE 5.01 LIMITATIONS AND CONSENT

The Contractor shall not assign, transfer, convey, sublet or otherwise dispose of this Contract or of his right, title, or interest therein, or his power to execute such Contract, or to assign any monies due or to become due thereunder to any other person, firm or corporation unless the previous written consent of the City shall first be obtained thereto and the giving of any such consent to a particular subcontract or assignment shall not dispense with the necessity of such consent to any further or other assignment.

Before making any subcontract, the Contractor must submit a

written statement to the Engineer, giving the name and address of the proposed contractor, the portion of the work and materials which he is to perform and furnish and any other information tending to prove that the proposed subcontractor has the necessary facilities, skill, integrity, past experience and financial resources to perform the work in accordance with the terms and conditions of this Contract.

If the City finds that the proposed subcontractor is qualified, the Contractor will be notified in writing. The City may revoke approval of any subcontractor when such subcontractor evidences an unwillingness or inability to perform his work in strict accordance with these Contract Documents. Notice of such revocation of approval will be given in writing to the Contractor.

The Contractor will promptly, upon request, file with the City a conformed copy of the subcontract. The Contractor shall cause appropriate provisions to be inserted in all subcontracts relative to the work to bind subcontractors to the Contractor by the terms of these Contract Documents, insofar as applicable to the work of subcontractors, and to give the Contractor the same power as regards terminating any subcontracts that the City may exercise over the Contractor under provisions of these Contract Documents.

The Contractor shall be required to perform with his own forces at least twenty-five (25) percent of the work, unless written consent to subcontract a greater percentage of the work is first obtained from the City.

ARTICLE 5.02 RESPONSIBILITY

The approval by the City of a subcontractor shall not relieve the Contractor of any of his responsibilities, duties, and liabilities hereunder. The Contractor shall be solely responsible to the City for the acts or defaults or omissions of his subcontractor and of such subcontractor's officers, agents, and employees, each of whom shall for all purposes be deemed to be the agent or employee of the Contractor. Nothing contained in the Contract Documents shall create any contractual relationship between any subcontractor and the City.

**SECTION 6
SECURITY AND GUARANTY**

ARTICLE 6.01 CONTRACT SECURITY

The Contractor shall execute and deliver to the City a Performance Bond on the form as provided herein, in an amount at least equal to one hundred (100) percent of the full Contract price, such Bond to be executed by a surety company acceptable to the City. The surety on such Performance Bond shall be a surety company duly authorized to do business in the State of Florida, and the Bond shall be issued or countersigned by a local resident producing agent of such surety company who is a resident of the State of Florida, regularly commissioned and licensed in said State, and satisfactory evidence of the authority of the person or persons executing such Bond shall be submitted with the Bond. The Performance Bond shall serve as security for the faithful performance of this Contract, including

maintenance and guaranty provisions, and for the payment of all persons performing labor and furnishing materials in connection with the Contract. The premiums on the Performance Bond shall be paid by the Contractor.

If, at any time, the City shall become dissatisfied with any surety or sureties then upon the Performance Bond, or if for any other reason such bond shall cease to be adequate security for the City, the Contractor shall, within five days after notice so to do, substitute an acceptable Bond in such form and sum and signed by such other sureties as may be satisfactory to the City. The premiums on such Bond shall be paid by the Contractor. No further partial payments shall be deemed due or shall be made until the new sureties have qualified.

ARTICLE 6.02 CONTRACTORS INSURANCE

Insurance required shall be as indicated on Special Instructions pages beginning with "INS-1"

ARTICLE 6.03 AGAINST CLAIMS AND LIENS

The City may withhold from the Contractor as much as any approved payments to him as may, in the opinion of the City, be necessary to secure (a) just claims of any persons supplying labor or materials to the Contractor or any of his subcontractors for the work then due and unpaid; (b) loss due to defective work not remedied, or (c) liability, damage, or loss due to injury to persons or damages to the work or property of other contractors, subcontractors, or others, caused by the act or neglect of the Contractor or of any of his subcontractors. The City shall have the right, as agent for the Contractor, to apply any such amounts so withheld in such manner as the City may deem proper to satisfy such claims or to secure such protection. Such application of such money shall be deemed payments for the account of the Contractor.

ARTICLE 6.04 MAINTENANCE AND GUARANTY

The Contractor hereby guarantees all the work furnished under this Contract against any defects in workmanship and materials for a period of one year following the date of final acceptance of the work by the City. Under this guarantee, the Contractor hereby agrees to make good, without delay, at his own expense, any failure of any part of the work due to faulty materials or manufacture, construction, or installation, or the failure of any equipment to perform satisfactorily all the work put upon it within the limits of the Contract Documents, and further, shall make good any damage to any part of the work caused by such failure. It is hereby agreed that the Performance Bond shall fully cover all guarantees contained in this Article.

It is also agreed that all warranties, expressed or implied, inure to the benefit of the City and are enforceable by the City.

**SECTION 7
CHANGES**

ARTICLE 7.01 MINOR CHANGES

The City reserves the right to make such additions, deductions, or changes to this Contract from time to time as

it deems necessary and in a manner not materially affecting the substance thereof or materially changing the price to be paid in order to carry out and complete more fully and perfectly the work herein agreed to be done and performed. This Contract shall in no way be invalidated by any such additions, deductions, or changes, and no claim by the Contractor shall be made for any loss of anticipated profits thereby.

Construction conditions may require that minor changes be made in the location and installation of the work and equipment to be furnished and other work to be performed hereunder, and the Contractor when ordered by the Engineer, shall make such adjustments and changes in said locations and work as may be necessary, without additional cost to the City, provided such adjustments and changes do not alter the character, quantity or cost of the work as a whole, and provided further that Plans and Specifications showing such adjustments and changes are furnished to the Contractor by the City within a reasonable time before any work involving such adjustment and changes is begun. The Engineer shall be the sole judge of what constitutes a minor change for which no additional compensation shall be allowed.

ARTICLE 7.02 EXTRA WORK

The City may at any time by a written order and without notice to the sureties require the performance of such extra work as it may find necessary or desirable. An order for extra work shall be valid only if issued in writing and signed by the Mayor and the work so ordered must be performed by the Contractor.

The amount of compensation to be paid to the Contractor for any extra work as so ordered shall be determined as follows:

(a) By such applicable unit prices, if any, as are set forth in the Proposal; or

(b) If no such unit prices are set forth then by a lump sum or other unit prices mutually agreed upon by the City and the Contractor; or

(c) If no such unit prices are set forth in the Proposal and if the parties cannot agree upon a lump sum or other unit prices then by the actual net cost in money to the Contractor of the extra work performed, which cost shall be determined as follows:

(1) For all labor and foreman in direct charge of the authorized operations, the Contractor shall receive the current local rate of wages to be agreed upon, in writing, before starting such work for each hour that said labor and foremen are actually engaged thereon, to which shall be added an amount equal to 25 percent of the sum thereof which shall be considered and accepted as full compensation for general supervision, FICA taxes, contributions under the Florida Unemployment Compensation Act, insurance, bond, subcontractor's profit and overhead, the furnishing of small tools and miscellaneous equipment used, such as picks, shovels, hand pumps, and similar items.

(2) For all materials used, the Contractor shall receive the actual cost of such materials delivered at the site or previously approved delivery point as established by original receipted bills. No percentage shall be added to this cost.

(3) For special equipment and machinery such as power-driven pumps, concrete mixers, trucks, and tractors, or other equipment, required for the economical performance of the authorized work, the Contractor shall receive payment based on the average local area rental price for each item of equipment and the actual time of its use on the work. No percentage shall be added to this sum.

(4) Records of extra work done under this procedure shall be reviewed at the end of each day by the Contractor or his representative and the Engineer. Duplicate copies of accepted records shall be made and signed by both Contractor or his representative and the Engineer, and one copy retained by each.

Request for payment for approved and duly authorized extra work shall be submitted in the same form as Contract work or in the case of work performed under paragraph (c) (1) above upon a certified statement supported by receipted bills. Such statement shall be submitted for the current Contract payment for the month in which the work was done.

ARTICLE 7.03 DISPUTED WORK

If the Contractor is of the opinion that any work required, necessitated, or ordered violates the terms and provisions of this Contract, he must promptly notify the Engineer, in writing, of his contentions with respect thereto and request a final determination thereof. If the Engineer determines that the work in question is Contract work and not extra work or that the order complained of is proper, he will direct the Contractor to proceed and the Contractor shall promptly comply. In order, however, to reserve his right to claim compensation for such work or damages resulting from such compliance, the Contractor must, within five (5) days after receiving notice of the Engineer's determination and direction, notify the City in writing that the work is being performed or that the determination and direction is being complied with under protest. Failure of the Contractor to notify shall be deemed as a waiver of claim for extra compensation or damages therefor.

Before final acceptance by the City, all matters of dispute must be adjusted to the mutual satisfaction of the parties thereto. Final determinations and decisions, in case any questions shall arise, shall constitute a condition precedent to the right of the Contractor to receive the money therefor until the matter in question has been adjusted.

ARTICLE 7.04 OMITTED WORK

The City may at any time by a written order and without notice to the sureties require the omission of such Contract work as it may find necessary or desirable.

An order for omission of work shall be valid only if signed by the Mayor and the work so ordered must be omitted by the Contractor. The amount by which the Contract price shall be reduced shall be determined as follows:

(a) By such applicable unit prices, if any, as are set forth in the Contract; or

(b) By the appropriate lump sum price set forth in the Contract; or

(c) By the fair and reasonable estimated cost to the City

of such omitted work as determined by the Engineer and approved by the City.

SECTION 8 CONTRACTOR'S EMPLOYEES

ARTICLE 8.01 CHARACTER AND COMPETENCY

The Contractor and his subcontractors shall employ upon all parts of the work herein contracted for only competent, skillful, and trustworthy workers. Should the Engineer at any time give notice, in writing, to the Contractor or his duly authorized representative on the work that any employee in his opinion is incompetent, unfaithful, disorderly, careless, unobservant of instructions, or in any way a detriment to the satisfactory progress of the work, such employee shall immediately be dismissed and not again allowed upon the site.

ARTICLE 8.02 SUPERINTENDENCE

The Contractor shall give his personal supervision to the faithful prosecution of the work and in case of his absence shall have a competent, experienced, and reliable supervisor or superintendent, acceptable to the Engineer on the site who shall follow without delay all instructions of the Engineer in the prosecution and completion of the work and every part thereof, in full authority to supply workers, material, and equipment immediately. He shall keep on hand at all times copies of the Contract Documents.

ARTICLE 8.03 EMPLOYMENT OPPORTUNITIES

The Contractor shall, in the performance of the work required to be done under this Contract, employ all workers without discrimination regarding race, creed, color, sex or national origin and must not maintain or provide facilities that are segregated on the basis of race, color, creed or national origin.

ARTICLE 8.04 RATES OF WAGES

On federally assisted projects, the rates of wages to be paid under this Contract shall not be less than the rates of wages set forth in Section 12 of this Agreement.

On other projects, no wage rate determination is included. Florida's Prevailing Wage Law (Section 215.19, Florida Statutes) was repealed effective April 25, 1979.

ARTICLE 8.05 PAYROLL REPORTS

The Contractor and each subcontractor shall, if requested to do so, furnish to the Engineer a duly certified copy of his payroll and also any other information required by the Engineer to satisfy him that the provisions of the law as to the hours of employment and rate of wages are being observed.

Payrolls shall be prepared in accordance with instructions furnished by the City and on approved forms. The Contractor shall not carry on his payroll any persons not employed by him. Subcontractor's employees shall be carried only on the payrolls of the employing subcontractor.

SECTION 9 CONTRACTOR'S DEFAULT

ARTICLE 9.01 CITY'S RIGHT AND NOTICE

It is mutually agreed that: (a) if the Contractor fails to begin work when required to do so, or (b) if at any time during the progress of the work it shall appear to the Engineer that the Contractor is not prosecuting the work with reasonable speed, or is delaying the work unreasonably and unnecessarily, or (c) if the force of workmen or quality or quantity of material furnished are not sufficient to insure completion of the work within the specified time and in accordance with the Specifications hereto attached, or (d) if the Contractor shall fail to make prompt payments for materials or labor or to subcontractors for work performed under the Contract, or (e) if legal proceedings have been instituted by others than the City in such manner as to interfere with the progress of the work and may subject the City to peril of litigation or outside claims of (f) if the Contractor shall be adjudged a bankrupt or make an assignment for the benefit of creditors, or (g) if in any proceeding instituted by or against the Contractor an order shall be made or entered granting an extension of time of payment, composition, adjustment, modification, settlement or satisfaction of his debts or liabilities, or (h) if a receiver or trustee shall be appointed for the Contractor or the Contractor's property, or (i) if the Contract or any part thereof shall be sublet without the consent of the City being first obtained in writing, or (j) if this Contract or any right, monies, or claim thereunder shall be assigned by the Contractor, otherwise than as herein specified, or (k) if the Contractor shall fail in any manner of substance to observe the provisions of this Contract, or (l) if any of the work, machinery, or equipment shall be defective, and shall not be replaced as herein provided, or (m) if the work to be done under this Contract shall be abandoned, then such fact or conditions shall be certified by the Engineer and thereupon the City without prejudice to any other rights or remedies of the City, shall have the right to declare the Contractor in default and so notify the Contractor by a written notice, setting forth the ground or grounds upon which such default is declared and the Contractor must discontinue the work, either as a portion of the work or the whole thereof, as directed.

ARTICLE 9.02 CONTRACTOR'S DUTY UPON DEFAULT

Upon receipt of notice that his Contract is in default, the Contractor shall immediately discontinue all further operations on the work or such part thereof, and shall immediately quit the site or such part thereof, leaving untouched all plant, materials, equipment, tools, and supplies.

ARTICLE 9.03 COMPLETION OF DEFAULTED WORK

The City, after declaring the Contractor in default, may then have the work completed or the defective equipment or machinery replaced or anything else done to complete the work in strict accordance with the Contract Documents by such means and in such manner, by Contract with or without public letting, or otherwise, as it may deem advisable,

utilizing for such purpose without additional cost to the City such of the Contractor's plant, materials, equipment, tools, and supplies remaining on the site, and also such subcontractors as it may deem advisable.

The City shall reimburse all parties, including itself, for the expense of such completion, including liquidated damages, if any, and the cost of reletting. The City shall deduct this expense from monies due or to become due to the Contractor under this Contract, or any part thereof, and in case such expense is more than the sum remaining unpaid of the original contract price, the Contractor and his sureties shall pay the amount of such deficiency to the City.

ARTICLE 9.04 PARTIAL DEFAULT

In case the City shall declare the Contractor in default as to a part of the work only, the Contractor shall discontinue such part, shall continue performing the remainder of the work in strict conformity with the terms of the Contract, and shall in no way hinder or interfere with any other contractor or person whom the City may engage to complete the work as to which the Contractor was declared in default.

SECTION 10 PAYMENTS

ARTICLE 10.01 PRICES

For the Contractor's complete performance of the work, the City will pay and the Contractor agrees to accept, subject to the terms and conditions hereof, the lump sum prices or unit prices in the Contractor's Proposal and the award made therein, plus the amount required to be paid for any extra work ordered under Article 7.02 hereof, less credit for any work omitted pursuant to Article 7.04 hereof. Under unit price items, the number of units actually required to complete the work under the Contract may be more than stated in the Proposal. The Contractor agrees that no claim will be made for any damages or for loss of profits because of a difference between the quantities of the various classes of work assumed and stated in the Proposal Form as a basis for comparing Proposals and the quantities of work actually performed.

The sum as awarded for any lump sum Contract or lump sum Contract Item shall represent payment in full for all of the various classes of work, including materials, equipment, and labor necessary or required to complete, in conformity with the Contract Document, the entire work shown, indicated or specified under the lump sum Contract or lump sum Contract Item.

The amount as awarded as a unit price for any unit price Contract Item shall represent payment in full for all the materials, equipment, and labor necessary to complete, in conformity with the Contract Documents, each unit of work shown, specified, or required under the said unit price Contract Item.

No payment other than the amount as awarded will be made for any class of work included in a lump sum Contract Item or a unit price Contract Item, unless specific provision is

made therefor in the Contract Documents.

ARTICLE 10.02 SUBMISSION OF BID BREAKDOWN

Within fifteen (15) days after the execution of this Contract, the Contractor must submit to the Engineer in duplicate an acceptable breakdown of the lump sums and unit prices bid for items of the Contract, showing the various operations to be performed under the Contract, as described in the progress schedule required under Article 4.02 hereof, and the value of each of such operations, the total of such items to equal the total price bid. The Contractor shall also submit such other information relating to the bid prices as may be required and shall revise the bid breakdown as directed. Thereafter, the breakdown may be used for checking the Contractor's applications for partial payments hereunder but shall not be binding upon the City or the Engineer for any purpose whatsoever.

ARTICLE 10.03 REPORTS, RECORDS AND DATA

The Contractor shall furnish to the Engineer such schedules of quantities and costs, progress schedules, reports, invoices, delivery tickets, estimates, records, and other data as the Engineer may request concerning work performed or to be performed and the materials furnished under the Contract.

ARTICLE 10.04 PAYMENTS BY CONTRACTOR

The Contractor shall pay (a) for all transportation and utility services not later than the 20th day of the calendar month following that in which such services are rendered, (b) for all materials, tools, and equipment delivered at the site of the project, and the balance of the cost thereof not later than the 30th day following the completion of that part of the work in or on which such materials, tools, and equipment are incorporated or used, and (c) to each of his subcontractors, not later than the 5th day following each payment to the Contractor, the respective amounts allowed the Contractor on account of the work performed by his subcontractors, to the extent of each subcontractor's interest therein; and proof of such payments or releases therefor shall be submitted to the Engineer upon request.

ARTICLE 10.05 PARTIAL PAYMENTS

On or about the first of each month, the Contractor shall make and certify an estimate, on forms prescribed by the City, of the amount and fair value of the work done, and may apply for partial payment therefor. The Contractor shall revise the estimate as the Engineer may direct. When satisfactory progress has been made, and shows that the value of the work completed since the last payment exceeds one percent (1%) of the total Contract price in amount, the Engineer will issue a certificate that such work has been completed and the value thereof. The City will then issue a voucher to the Contractor in accordance with the following schedule:

FOR CONTRACT AMOUNTS UNDER \$250,000

(A) In the amount of ninety percent (90%) of the value of the work completed as certified until construction is one hundred percent (100%) complete (operational or beneficial occupancy), the withheld amount may be reduced below ten percent (10%), at the Engineer's option, to only that amount necessary to assure completion.

FOR CONTRACT AMOUNTS OVER \$250,000

(A) In the amount of ninety percent (90%) of the value of the work completed as certified until construction is fifty percent (50%) complete.

(B) When the dollar value, as determined by the Engineer, of satisfactorily completed work in place is greater than fifty percent (50%) of the original contract price, vouchers for partial payment will be issued by the City to the Contractor in the amount of one hundred percent (100%) of the value of the work, above 50%, completed as certified for that payment period.

(C) If the Contractor has performed satisfactorily and the work is substantially complete (operational or beneficial occupancy) the withheld amount may be reduced, at the Engineer's option, to only that amount necessary to assure completion.

In addition to the Conditions set forth in (A), (B), and (C) above, payments will always be less any sums that may be retained or deducted by the City under the terms of any of the contract documents and less any sums that may be retained to cover monetary guarantees for equipment, materials or progress performance.

Payment on estimates made on or about the first of the month may be expected on or about the 20th of the month.

Unless specified otherwise in the Contract Items, the delivered cost of equipment and nonperishable materials suitably stored at the site of the work and tested for adequacy may be included in the Contractor's application for partial payment provided, however, that the Contractor shall furnish evidence satisfactory to the City that the Contractor is the unconditional owner and in possession of such materials or equipment. The amount to be paid will be 90 percent of the invoice cost to the Contractor which cost shall be supported by receipted bills within 30 days of the date of payment by the City to the Contractor. Such payment shall not relieve the Contractor from full responsibility for completion of the work and for protection of such materials and equipment until incorporated in the work in a permanent manner as required by the Contract Documents.

Before any payment will be made under this Contract, the Contractor and every subcontractor, if required, shall deliver to the Engineer a written, verified statement, in satisfactory form, showing in detail all amounts then due and unpaid by such Contractor or subcontractor to all laborers, workmen, and mechanics, employed by him under the Contract for the performance of the work at the site thereof, for daily or weekly wages, or to other persons for materials, equipment, or supplies delivered at the site of the work during the period covered by the payment under consideration.

ARTICLE 10.06 FINAL PAYMENT

Under determination of satisfactory completion of the work under this Contract as provided in Article 4.07 hereof, the Engineer will prepare the final estimate showing the value of the completed work. This estimate will be prepared within 30 days after the date of completion or as soon thereafter as the necessary measurements and computations can be made.

All prior certificates and estimates, being approximate only, are subject to correction in the final estimate and payment.

When the final estimate has been prepared and certified by Engineer, he will submit to the Mayor and City Council the final certificate stating that the work has been completed and the amount based on the final estimate remaining due to the Contractor. The City will then accept the work as fully completed and will, not later than 30 days after the final acceptance, as defined in Article 1.02, of the work done under this Contract, pay the Contractor the entire amount so found due thereunder after deduction of all previous payments and all percentages and amounts to be kept and retained under provisions of this Contract; provided, however, and it is understood and agreed that, as a precedent to receiving final payment, the Contractor shall submit to the City a sworn affidavit that all bills for labor, service, materials, and subcontractors have been paid and that there are no suits pending in connection with this work. The City, at its option, may permit the Contractor to execute a separate surety bond in a form satisfactory to the City. The surety bond shall be in the full amount of the suit or suits.

Neither the final payment nor any part of the retained percentage shall be paid until the Contractor, if required, shall furnish the City with a complete release from any should remain unsatisfied after all payments are made, the Contractor shall refund to the City all monies which the City may be compelled to pay in discharging such claim, including incidental costs and attorney's fees.

ARTICLE 10.07 ACCEPTANCE OF FINAL PAYMENT

The acceptance by the Contractor, or by anyone claiming by or through him, of the final payment shall operate as and shall be a release to the City and every officer and agent thereof from any and all claims and liability to the Contractor for anything done or furnished in connection with the work or project and for any act or neglect of the Contractor or of any others relating to or affecting the work. No payment, however, final or otherwise, shall operate to release the Contractor or his sureties from any obligations under this Contract or the Performance Bond.

SECTION 11 MISCELLANEOUS PROVISIONS

ARTICLE 11.01 CONTRACTOR'S WARRANTIES

In consideration of, and to induce the award of this contract to him, the Contractor represents and warrants:

- (a) That he is not in arrears to the City upon debt or contract, and he is not a defaulter, as surety, contractor, or otherwise.
- (b) That he is financially solvent and sufficiently experienced and competent to perform the work.
- (c) That the work can be performed as called for by the Contract Documents.
- (d) That the facts stated in his proposal and the information given by him are true and correct in all respects.
- (e) That he is fully informed regarding all the conditions affecting the work to be done and labor and materials to be

furnished for the completion of this Contract, and that his information was secured by personal investigation and research.

ARTICLE 11.02 PATENTED DEVICES, MATERIAL AND PROCESSES

It is mutually understood and agreed that Contract prices include all royalties and costs arising from patents, trademarks, and copyrights in any way involved in the work. Whenever the Contractor is required or desires to use any design, device, material, or process covered by letters of patent or copyright, the Contractor shall indemnify and save harmless the City, its officers, agents and employees from any and all claims for infringement by reason of the use of any such patented design, device, tool, material, equipment, or process, to be performed under the Contract, and shall indemnify the said City, its officers, agents, and employees for any costs, expenses, and damages which may be incurred by reason of such infringement at any time during the prosecution or after completion of the work.

ARTICLE 11.03 SUITS AT LAW

In case any action at law or suit in equity may or shall be brought against the City or any of its officers, agents, or employees for or on account of the failure, omission, or neglect of the Contractor or his subcontractors, employees, or agents, to do or perform any of the covenants, acts, matters, or things by this Contract undertaken to be done or performed by the Contractor or his subcontractors, employees, or agents, or from any injuries done to property or persons and caused by the negligence or alleged negligence of the Contractor or his subcontractors, employees, or agents, or in any other manner arising out of the performance of this Contract, then the Contractor shall immediately assume and take charge of the defense of such actions or suits in like manner and to all intents and purposes as if said actions or suits have been brought directly against the Contractor, and the Contractor shall also indemnify and save harmless the City, its officers, agents, and employees from any and all loss, cost or damage whatever arising out of such actions or suits, in like manner and to all intents and purposes as if said actions or suits have been brought directly against the Contractor.

The Contractor shall and does hereby assume all liability for and agrees to indemnify the City or its Engineer against any or all loss, costs, damages, and liability for any or by reason of any lien, claims or demands, either for materials purchased or for work performed by laborers, mechanics, and others and from any damages, costs, actions, or causes of action and judgement arising from injuries sustained by mechanics, laborers, or other persons by reason of accidents or otherwise, whether caused by the carelessness or inefficiency or neglect of said Contractor, his subcontractors, agents, employees, workmen or otherwise.

ARTICLE 11.04 CLAIMS FOR DAMAGES

If the Contractor shall claim compensation for any damage sustained, other than for extra or disputed work covered by Article 7.02 and 7.03 hereof, by reason of any act or omission of the City, its agents, or any persons, he shall, within five days after sustaining such damage, make and

deliver to the Engineer a written statement of the nature of the damage sustained and of the basis of the claim against the City. On or before the 15th of the month succeeding that in which any damage shall have been sustained, the Contractor shall make and deliver to the Engineer an itemized statement of the details and amounts of such damage, duly verified by the Contractor. Unless such statements shall be made delivered within the times aforesaid, it is stipulated that and all claims for such compensation shall be forfeited and invalidated, and the Contractor shall not be entitled to payment on account of such claims.

ARTICLE 11.05 NO CLAIMS AGAINST INDIVIDUALS

No claim whatsoever shall be made by the Contractor against any officer, agent, employee of the City for, or on account of, anything done or omitted to be done in connection with this Contract.

ARTICLE 11.06 LIABILITY UNAFFECTED

Nothing herein contained shall in any manner create any liability against the City on behalf of any claim for labor, services, or materials, or of subcontractors, and nothing herein contained shall affect the liability of the Contractor or his sureties to the City or to any workmen or materialsmen upon bond given in connection with this Contract.

ARTICLE 11.07 INDEMNIFICATION PROVISIONS

Whenever there appears in this Agreement, or in the other Contract Documents made a part hereof, an indemnification provision within the purview of Chapter 725.06, Laws of Florida, the monetary limitation on the extent of the indemnification under each such provision shall be One Million Dollars or a sum equal to the total Contract price, whichever shall be the greater.

ARTICLE 11.08 UNLAWFUL PROVISIONS DEEMED STRICKEN

If this contract contains any unlawful provisions not an essential part of the Contract and which shall not appear to have a controlling or material inducement to the making thereof, such provisions shall be deemed of no effect and shall, upon notice by either party, be deemed stricken from the Contract without affecting the binding force of the remainder.

ARTICLE 11.09 LEGAL PROVISIONS DEEMED INCLUDED

Each and every provision of any law and clause required by law to be inserted in this Contract shall be deemed to be inserted herein, and the Contract shall be read and enforced as though it were included herein and if, through mistake or otherwise, any such provision is not inserted or is not correctly inserted, then upon application of either party the Contract shall forthwith be physically amended to make such insertion.

ARTICLE 11.10 DEATH OR INCOMPETENCY OF CONTRACTOR

In the event of death or legal incompetency of a Contractor who shall be an individual or surviving member of a contracting firm, such death or adjudication of incompetency

shall not terminate the Contract, but shall act as default hereunder to the effect provided in Article 9.01 hereof and the estate of the Contractor and his surety shall remain liable hereunder to the same extent as though the Contractor had lived. Notice of default, as provided in Article 9.01 hereof, shall not be required to be given in the event of such death or adjudication of incompetency.

ARTICLE 11.11 NUMBER AND GENDER OF WORDS

Whenever the context so admits or requires, all references herein in one number shall be deemed extended to and including the other number, whether singular or plural, and the use of any gender shall be applicable to all genders.

ARTICLE 11.12 ACCESS TO RECORDS

Representatives of Federal Agencies, if applicable, and the State of Florida shall have access to the work whenever it is in preparation of progress. On federally assisted projects the Federal Agency, the Comptroller General of the United States, or any authorized representative shall have access to any books, documents, papers, and records of the Contractor which are pertinent to the project for the purpose of making audit, examination, excerpts, and transcription thereof.

**SECTION 12
LABOR STANDARDS**

ARTICLE 12.01 LABOR STANDARDS

The Contractor shall comply with all of the regulations set forth in "Labor Standards Provisions for Federally Assisted Construction Contracts", which may be attached, and any applicable Florida Statutes.

ARTICLE 12.02 NOTICE TO LABOR UNIONS

If required, the Contractor shall provide Labor Unions and other organizations of workers, and shall post, in a conspicuous place available to employees or applicants for employment, a completed copy of the form entitled "Notice to Labor Unions or Other Organizations of Workers" attached to and made a part of this Agreement.

ARTICLE 12.03 SAFETY AND HEALTH REGULATIONS

The Contractor shall comply with the Department of Labor Safety and Health Regulations for construction promulgated under the Occupational Safety and Health Act of 1970 (PL 91- 596) and under Section 107 of the Contract Work Hours and Safety Standards Act (PL 91-54). Nothing in these Acts shall be construed to supersede or in any manner affect any worker's compensation law or statutory rights, duties, or liabilities of employers and employees under any law with respect to injuries, diseases, or death of employees arising out of, or in the course of, employment.

ARTICLE 12.04 EEO AFFIRMATIVE ACTION REQUIREMENTS

The Contractor understands and agrees to be bound by the equal opportunity requirements of Federal regulations which shall be applicable throughout the performance of work under this Contract. The Contractor also agrees to similarly

bind contractually each subcontractor. In policies, the Contractor agrees to engage in Affirmative Action directed at promoting and ensuring equal employment opportunity in the work force used under the Contract (and the Contractor agrees to require contractually the same effort of all subcontractors whose subcontractors exceed \$100,000). The Contractor understands and agrees that "Affirmative Action" as used herein shall constitute a good faith effort to achieve and maintain minority employment in each trade in the on-site work force used on the Contract.

ARTICLE 12.05 PREVAILING RATES OF WAGES

Florida's prevailing wage law was repealed effective April 25, 1979.

For Federally assisted projects, appropriate prevailing wage rate determinations are indicated on pages beginning with WR-1.

* * * * *

IN WITNESS THEREOF, the parties have hereunto set their hands and seals, and such of them as are corporation have caused these present to be signed by their duly authorized officers.

CITY OF TAMPA, FLORIDA

Bob Buckhorn, Mayor
(SEAL)

ATTEST:

City Clerk

Approved as to Form:

The execution of this document was authorized
by Resolution No. _____

Justin R. Vaske, Assistant City Attorney

Contractor

By: _____
(SEAL)

Title:

ATTEST:

Secretary

TAMPA PAYMENT (ACKNOWLEDGMENT OF PRINCIPAL)

STATE OF _____)
) SS:
COUNTY OF _____)

For a Corporation:

STATE OF _____
COUNTY OF _____

The foregoing instrument was acknowledged before me this ____ of _____, 2014 by _____ of _____, a _____ corporation, on behalf of the corporation. He/she is ____ personally known or has ____ produced _____ as identification.

Notary

My Commission Expires:

For an Individual:

STATE OF _____
COUNTY OF _____

The foregoing instrument was acknowledged before me this ____ of _____, 2014 by _____ who is ____ personally known to me or has ____ produced _____ as identification.

Notary

My Commission Expires:

For a Firm:

STATE OF _____
COUNTY OF _____

The foregoing instrument was acknowledged before me this ____ of _____, 2014 by _____ who signed on behalf of the said firm. He/she is ____ personally known or has ____ produced _____ as identification.

Notary

My Commission Expires:

PUBLIC CONSTRUCTION BOND

Bond No. (enter bond number) _____

Name of Contractor: _____

Principal Business Address of Contractor: _____

Telephone Number of Contractor: _____

Name of Surety (if more than one list each): _____

Principal Business Address of Surety: _____

Telephone Number of Surety: _____

Owner is The City of Tampa, Florida

Principal Business Address of Owner: _____ 306 E Jackson St, Tampa, FL 33602

_____ Contract Administration Department (280A4N)

Telephone Number of Owner: _____ 813/274-8456

Contract Number Assigned by City to contract which is the subject of this bond: _____

Legal Description or Address of Property Improved or Contract Number is: _____

General Description of Work and Services: _____

KNOW ALL MEN BY THESE PRESENTS That we, _____

(Name of Contractor)

as Principal, hereinafter called CONTRACTOR, of the State of _____, and

(Name of Surety)

a corporation organized and existing under and by virtue of the laws of the State of _____, and regularly authorized to do business in the State of Florida, as SURETY, are held and firmly bound unto the City of Tampa, a municipal corporation organized and existing under the laws of the State of Florida, hereinafter called Owner, in the penal sum of _____ Dollars and _____ Cents (\$ _____), lawful money of the United States of America, for the payment whereof well and truly to be made, we bind ourselves, our heirs, executors, and administrators, successors and assigns, jointly and severally, firmly by these presents.

THE CONDITION OF THIS BOND is that if Principal:

1. Performs the contract dated _____, _____, 20____, between Principal and Owner for construction of _____, the contract being made a part of this bond by reference, in the time and in the manner prescribed in the contract; and
2. Promptly makes payments to all claimants, as defined in Section 255.05(1) (Section 713.01), Florida Statutes, supplying Principal with labor, materials, or supplies, used directly or indirectly by Principal in the prosecution of the work provided for in the contract; and
3. Pays Owner all losses, damages, expenses, costs, and attorney's fees, including appellate proceedings, that Owner sustains because of a default by Principal under the contract; and
4. Performs the guarantee of all work and materials furnished under the contract for the time specified in the contract, then this bond is void; otherwise it remains in full force.
5. Contractor and Surety acknowledge that the Work for which this bond has been issued may be one of several such contract documents for a group of projects. This bond does not secure covenants to pay for or to perform design services survey or program management services. The Owner/Obligee is expected to reasonably account for damages that are caused to Owner with respect to Principal's (Contractor's) default in performance of the scope of the Work incorporated by reference into the bond, and notwithstanding any contractual or common law remedy permitted to Owner as against Contractor, the obligation of Surety for any damages under this bond shall be determined by the cost of completion of the Work less the contract balance unpaid upon default of Contractor for the Work plus liquidated damages at the rate of \$500.00 per day for delays by the Contractor and/or Surety in reaching substantial completion.
6. The notice requirements for claimants and conditions for entitlement to payment set forth in Section 255.05, Fla. Stat. and the limitations period to actions upon Section 255.05, Fla. Stat. bonds apply to claimants seeking payment from surety under this bond. Any action instituted by a claimant under this bond for payment must be in accordance with the notice and time limitation provisions in Section 255.05, Florida Statutes.
7. The Surety, for value received, hereby stipulates and agrees that no changes, extensions of time, alterations or additions to the terms of the contract documents or other Work to be performed hereunder, or the specifications referred to therein shall in any way affect its obligations under this bond, and it does hereby waive notice of any such changes, extensions of time, alterations or additions to the terms of the Contract or to Work or to the specifications.

8. The above SURETY states that it has read all of the Contract Documents made by the CONTRACTOR with the CITY, hereto attached, and the terms and conditions of the contract and work, and is familiar therewith and in particular those portions of the Agreement concerning the guaranty of such CONTRACTOR for a period of one year following the date of the final acceptance of the completed work under the Contract by the CITY, all of which this BOND includes.

DATED ON _____, 20__

(Name of Principal)

(Name of Surety)

(Principal Business Address)

(Surety Address)

By _____

By _____
(As Attorney in Fact)*

Title _____

Telephone Number of Surety

Telephone Number of Principal

Accepted by City of Tampa:

Countersignature:

By _____
Bob Buckhorn, Mayor

(Name of Local Agency)

Date: _____ 20__

(Address of Resident Agent)

By _____

Approved as to legal sufficiency:

Title _____

By _____
Assistant City Attorney

Telephone Number of Local Agency

Date: _____, 20__

*(As Attorney in Fact) attach Power of Attorney and Current Certificate with Original Signature

SPECIFICATIONS GENERAL PROVISIONS

SECTION 1 SCOPE AND INTENT

G-1.01 DESCRIPTION

The work to be done consists of the furnishing of all labor, materials and equipment, and the performance of all work included in this Contract.

G-1.02 WORK INCLUDED

The Contractor shall furnish all labor, superintendence, materials, plant, power, light, heat, fuel, water, tools, appliances, equipment, supplies, and other means of construction necessary or proper for performing and completing the work. He shall obtain and pay for all required permits. He shall perform and complete the work in the manner best calculated to promote rapid construction consistent with safety of life and property and to the satisfaction of the Engineer, and in strict accordance with the Contract Documents. The Contractor shall clean up the work and maintain it during and after construction, until accepted, and shall do all work and pay all costs incidental thereto. He shall repair or restore all structures and property that may be damaged or disturbed during performance of the work.

The cost of incidental work described in these General Provisions, for which there are no specific Contract Items, shall be considered as part of the overhead cost of doing the work and shall be included in the prices for the various Contract Items. No additional payment will be made therefor.

The Contractor shall provide and maintain such modern plant, tools, and equipment as may be necessary, in the opinion of the Engineer, to perform in a satisfactory and acceptable manner all the work required by this Contract. Only equipment of established reputation and proven efficiency shall be used. The Contractor shall be solely responsible for the adequacy of his plant and equipment, prior approval of the Engineer notwithstanding.

G-1.03 PUBLIC UTILITY INSTALLATIONS AND STRUCTURES

Public utility installations and structures shall be understood to include all poles, tracks, pipes, wires, conduits, house service connections, vaults, manholes, and all other appurtenances and facilities pertaining thereto whether owned or controlled by the City, other governmental bodies or privately owned by individuals, firms, or corporations, and used to serve the public with transportation, traffic control, gas, electricity, telephone, sewerage, drainage, water or other public or private property which may be affected by the work.

The Contract Documents contain data relative to existing public utility installations and structures above and below the ground surface. These data are not guaranteed as to their completeness or accuracy and it is the responsibility of the Contractor to make his own investigations to inform himself

fully of the character, condition and extent of all such installations and structures as may be encountered and as may affect the construction operations.

The Contractor shall protect all public utility installations and structures from damage during the work. Access across any buried public utility installation or structure shall be made only in such locations and by means approved by the Engineer. The Contractor shall so arrange his operations as to avoid any damage to these facilities. All required protective devices and construction shall be provided by the Contractor at his expense. All existing public utilities damaged by the Contractor which are shown on the Plans or have been located in the field by the utility shall be repaired by the Contractor, at his expense, as directed by the Engineer. No separate payment shall be made for such protection or repairs to public utility installations or structures.

Public utility installations or structures owned or controlled by the City or other governmental body which are shown on the Plans to be removed, relocated, replaced or rebuilt by the Contractor shall be considered as a part of the general cost of doing the work and shall be included in the prices bid for the various Contract Items. No separate payment shall be made therefor.

Where public utility installations or structures owned or controlled by the City or other governmental body are encountered during the course of the work, and are not indicated on the Plans or in the Specifications, and when, in the opinion of the Engineer, removal, relocation, replacement or rebuilding is necessary to complete the work under this Contract, such work shall be accomplished by the utility having jurisdiction or such work may be ordered, in writing by the Engineer, for the Contractor to accomplish. If such work is accomplished by the utility having jurisdiction it will be carried out expeditiously and the Contractor shall give full cooperation to permit the utility to complete the removal, relocation, replacement or rebuilding as required. If such work is accomplished by the Contractor, it will be paid for as extra work as provided for in Article 7.02 of the Agreement.

The Contractor shall, at all times in performance of the work, employ approved methods and exercise reasonable care and skill so as to avoid unnecessary delay, injury, damage or destruction of public utility installations and structures; and shall, at all times in the performance of the work, avoid unnecessary interference with, or interruption of, public utility services, and shall cooperate fully with the owners thereof to that end.

All City and other governmental utility departments and other owners of public utilities, which may be affected by the work, will be informed in writing by the Engineer within two weeks after the execution of the Contract or Contracts covering the work. Such notice will set out, in general, and direct attention to, the responsibilities of the City and other governmental

utility departments and other owners of public utilities for such installations and structures as may be affected by the work and will be accompanied by one set of Plans and Specifications covering the work under such Contract or Contracts.

In addition to the general notice given by the Engineer, the Contractor shall give written notice to all City and other governmental utility departments and other owners of public utilities of the location of his proposed construction operations, at least forty-eight (48) hours in advance of breaking ground in any area or on any unit of the work. This can be accomplished by making the appropriate contact with the "Underground Utility Notification Center for Excavators (Call Candy)".

The maintenance, repair, removal, relocation, or rebuilding of public utility installations and structures, when accomplished by the Contractor as herein provided, shall be done by methods approved by the Engineer.

SECTION 2 PLANS AND SPECIFICATIONS

G-2.01 PLANS

The Plans referred to in the Contract Documents bear the general project name and number as shown in the Notice To Bidders.

When obtaining data and information from the Plans, figures shall be used in preference to scaled dimensions, and large scale drawings in preference to small scale drawings.

G-2.02 COPIES FURNISHED TO CONTRACTOR

After the Contract has been executed, the Contractor will be furnished with five sets of paper prints, the same size as the original drawings, of each sheet of the Plans and five copies of the Specifications. Additional copies of the Plans and Specifications, when requested, may be furnished to the Contractor at cost of reproduction.

The Contractor shall furnish each of the subcontractors, manufacturers, and material suppliers such copies of the Contract Documents as may be required for his work.

G-2.03 SUPPLEMENTARY DRAWINGS

When, in the opinion of the Engineer, it becomes necessary to explain more fully the work to be done or to illustrate the work further or to show any changes which may be required, drawings known as Supplementary Drawings, with specifications pertaining thereto, will be prepared by the Engineer and five paper prints thereof will be given to the Contractor.

The Supplementary Drawings shall be binding upon the Contractor with the same force as the Plans. Where such Supplementary Drawings require either less or more than the estimated quantities of work, credit to the City or compensation therefor to the Contractor shall be subject to the terms of the Agreement.

G-2.04 CONTRACTOR TO CHECK PLANS AND DATA

The Contractor shall verify all dimensions, quantities, and details shown on the Plans, Supplementary Drawings, Schedules, Specifications, or other data received from the Engineer, and shall notify him of all errors, omissions, conflicts, and discrepancies found therein. Failure to discover or correct errors, conflicts or discrepancies shall not relieve the Contractor of full responsibility for unsatisfactory work, faulty construction or improper operation resulting therefrom nor from rectifying such conditions at his own expense. He will not be allowed to take advantage of any errors or omissions as full instructions will be furnished by the Engineer, should such errors or omissions be discovered. All schedules are given for the convenience of the Engineer and the Contractor and are not guaranteed to be complete. The Contractor shall assume all responsibility for the making of estimates of the size, kind, and quality of materials and equipment included in work to be done under the Contract.

G-2.05 SPECIFICATIONS

The specifications consist of four parts, the General Provisions, the Technical Specifications, the Special Provisions and the Contract Items. The General Provisions and Technical Specifications contain general requirements which govern the work. The Special Provisions and the Contract Items modify and supplement these by detailed requirements for the work and shall always govern, whenever there appears to be conflict.

G-2.06 INTENT

All work called for in the Specifications applicable to this Contract, but not shown on the Plans in their present form, or vice versa, shall be of like effect as if shown or mentioned in both. Work not specified in either the Plans or in the Specifications, but involved in carrying out their intent or in the complete and proper execution of the work, is required and shall be performed by the Contractor as though it were specifically delineated or described.

The apparent silence of the Specifications as to any detail, or the apparent omission from them of a detailed description concerning any work to be done and materials to be furnished, shall be regarded as meaning that only the best general practice is to prevail and that only material and workmanship of the best quality is to be used, and interpretation of these Specifications shall be made upon that basis.

SECTION 3 WORKING DRAWINGS

G-3.01 SCOPE

The Contractor shall promptly prepare and submit layout, detail and shop drawings to insure proper construction, assembly, and installation of the work using those materials and methods as hereafter specified under the Technical Specifications, Special Provisions and Contract Items.

These drawings shall accurately and distinctly present the following:

- a. All working and erection dimensions.
- b. Arrangements and sectional views.
- c. Necessary details, including complete information for making connections between work under this Contract and work under other Contracts.
- d. Kinds of materials and finishes.
- e. Parts listed and description thereof.

Drawings for mechanical equipment shall present, where applicable, such data as dimensions, weight and performance characteristics. These data shall show conformance with the performance characteristics and other criteria incorporated in the Plans and Specifications.

Each drawing shall be dated and shall contain the name of the project, Division number and description, the technical specifications section number, names of equipment or materials and the location at which the equipment or materials are to be installed. Location shall mean both physical location and location relative to other connected or attached material. The Engineer will return unchecked any submittal which does not contain complete data on the work and full information on related matters.

Stock or standard drawings will not be accepted for review unless full identification and supplementary information is shown thereon in ink or typewritten form.

The Contractor shall review all working drawing submittals before transmitting them to the Engineer to determine that they comply with requirements of the Specifications. Drawings which are incomplete or are not in compliance with the Contract Documents shall not be submitted for processing by the Engineer. The Contractor shall place his stamp of approval on all working drawings submitted to the Engineer to indicate compliance with the above.

G-3.02 APPROVAL

If the working drawings show departures from the Contract requirements, the Contractor shall make specific mention thereof in his letter of submittal; otherwise approval of such submittals shall not constitute approval of the departure. Approval of the drawings shall constitute approval of the subject matter thereof only and not of any structure, material, equipment, or apparatus shown or indicated.

The approval of drawings will be general and shall not relieve the Contractor of responsibility for the accuracy of such drawings, nor for the proper fitting and construction of the work, nor for the furnishing of materials or work required by the Contract and not indicated on the drawings. No work called for by working drawings shall be done until such drawings have been approved by the Engineer.

The procedure in seeking approval of the working drawings shall be as follows:

1. The Contractor shall submit four complete sets of drawings

and other descriptive data together with one copy of a letter of transmittal to the Engineer for approval. The letter of transmittal shall contain the name of the project, contract number, technical specifications section number, the name of the Contractor, a list of drawings with numbers and titles, and any other pertinent information.

2. Drawings or descriptive data will be stamped "Approved", "Approved Subject to Corrections Marked", or "Examined and Returned for Correction" and one copy with a letter of transmittal will be returned to the Contractor.

3. If a drawing or other data is stamped "Approved", the Contractor shall insert the date of approval on five additional copies of the document and transmit the five copies to the Engineer together with one copy of a letter of transmittal containing substantially the same information as described in Instruction 1. above.

4. If a drawing or other data is stamped "Approved Subject to Corrections Marked", the Contractor shall make the corrections indicated and proceed as in Instruction 3., above.

5. If a drawing or data is stamped "Examined and Returned for Correction", the Contractor shall make the necessary corrections and resubmit the documents as set forth in Instruction 1., above. The letter of transmittal shall indicate that this is a resubmittal.

The Contractor shall revise and resubmit the working drawings as required by the Engineer, until approval thereof is obtained.

SECTION 4 MATERIALS AND EQUIPMENT

G-4.01 GENERAL REQUIREMENTS

All materials, appliances, and types or methods of construction shall be in accordance with the Specifications and shall, in no event, be less than that necessary to conform to the requirements of any applicable laws, ordinances, and codes.

All materials and equipment shall be new, unused, and correctly designed. They shall be of standard first grade quality, produced by expert personnel, and intended for the use for which they are offered. Materials or equipment which, in the opinion of the Engineer, are inferior or of a lower grade than indicated, specified, or required will not be accepted.

The quality of Workmanship and Materials entering into the work under this Contract shall conform to the requirements of the pertinent sections, clauses, paragraphs, and sentences, both directly and indirectly applicable thereto, of that part of the Technical Specifications, whether or not direct reference to such occurs in the Contract Items.

Equipment and appurtenances shall be designed in conformity with ANSI, ASME, IEEE, NEMA and other

generally accepted standards and shall be of rugged construction and of sufficient strength to withstand all stresses which may occur during fabrication, testing, transportation, installation, and all conditions of operation. All bearings and moving parts shall be adequately protected against wear by bushings or other approved means and shall be fully lubricated by readily accessible devices. Details shall be designed for appearance as well as utility. Protruding members, joints, corners, gear covers, and the like, shall be finished in appearance. All exposed welds shall be ground smooth and the corners of structural shapes shall be mitered.

Equipment shall be of the approximate dimensions as indicated on the Plans or as specified, shall fit the spaces shown on the Plans with adequate clearances, and shall be capable of being handled through openings provided in the structure for this purpose. The equipment shall be of such design that piping and electrical connections, ductwork, and auxiliary equipment can be assembled and installed without causing major revisions to the location or arrangement of any of the facilities.

Machinery parts shall conform exactly to the dimensions shown on the working drawings. There shall be no more fitting or adjusting in setting up a machine than is necessary in assembling high grade apparatus of standard design. The equivalent parts of identical machines shall be made interchangeable. All grease lubricating fittings on equipment shall be of a uniform type. All machinery and equipment shall be safeguarded in accordance with the safety codes of the ANSI and applicable state and local codes.

G-4.02 MANUFACTURER

The names of proposed manufacturers, suppliers, material, and dealers who are to furnish materials, fixtures, equipment, appliances or other fittings shall be submitted to the Engineer for approval, as early as possible, to afford proper investigation and checking. Such approval must be obtained before shop drawings will be checked. No manufacturer will be approved for any materials to be furnished under this Contract unless he shall be of good reputation and have a plant of ample capacity. He shall, upon the request of the Engineer, be required to submit evidence that he has manufactured a similar product to the one specified and that it has been previously used for a like purpose for a sufficient length of time to demonstrate its satisfactory performance.

All transactions with the manufacturers or subcontractors shall be through the Contractor, unless the Contractor shall request, in writing to the Engineer, that the manufacturer or subcontractor deal directly with the Engineer. Any such transactions shall not in any way release the Contractor from his full responsibility under this Contract.

Any two or more pieces of material or equipment of the same kind, type or classification, and being used for identical types of service, shall be made by the same manufacturer.

G-4.03 REFERENCE TO STANDARDS

Whenever reference is made to the furnishing of materials or

testing thereof to conform to the standards of any technical society, organization or body, it shall be construed to mean the latest standard, code, specification or tentative specification adopted and published at the date of advertisement for proposals, even though reference has been made to an earlier standard, and such standards are made a part hereof to the extent which is indicated or intended.

Reference to a technical society, organization or body may be made in the Specifications by abbreviations, in accordance with the following list:

AASHTO for American Association of State Highway and Transportation Officials (formerly AASHO)
ACI for American Concrete Institute
AGMA for American Gear Manufacturer's Association
AFBMA for Anti-Friction Bearing Manufacturer's Association
AISC for American Institute of Steel Construction
AISI for American Iron and Steel Institute
ANSI for American National Standards Institute
ASCE for American Society of Civil Engineers
ASTM for American Society for Testing and Materials
ASME for American Society of Mechanical Engineers
AWS for American Welding Society
AWWA for American Water Works Association
AWPA for American Wood Preservers Association
CEMA for Conveyor Equipment Manufacturers Association
CIPRA for Cast Iron Pipe Research Association
IEEE for Institute of Electrical and Electronic Engineers
IPCEA for Insulated Power Cable Engineers Association
NEC for National Electrical Code
NEMA for National Electrical Manufacturers Association
SAE for Society of Automotive Engineers
SHBI for Steel Heating Boiler Institute
Fed.Spec. for Federal Specifications
Navy Spec. for Navy Department Specifications
U.L.,Inc. for Underwriters' Laboratories, Inc.

When no reference is made to a code, standard or specification, the Standard Specifications of the ANSI, the ASME, the ASTM, the IEEE, or the NEMA shall govern.

G-4.04 SAMPLES

The Contractor shall, when required, submit to the Engineer for approval typical samples of materials and equipment. The samples shall be properly identified by tags and shall be submitted sufficiently in advance of the time when they are to be incorporated into the work, so that rejections thereof will not cause delay. A letter of transmittal, in duplicate, from the Contractor requesting approval must accompany all such samples.

G-4.05 EQUIVALENT QUALITY

Whenever, in the Contract Documents, an article, material, apparatus, equipment, or process is called for by trade name or by the name of a patentee, manufacturer, or dealer or by reference to catalogs of a manufacturer or dealer, it shall be understood as intending to mean and specify the article, material, apparatus, equipment or process designated, or any

equal thereto in quality, finish, design, efficiency, and durability and equally serviceable for the purposes for which it is intended.

Whenever material or equipment is submitted for approval as being equal to that specified, the decision as to whether or not such material or equipment is equal to that specified shall be made by the Engineer.

Upon rejection of any material or equipment submitted as the equivalent of that specifically named in the Contract, the Contractor shall immediately proceed to furnish the designated material or equipment.

Neither the approval by the Engineer of alternate material or equipment as being equivalent to that specified nor the furnishing of the material or equipment specified, shall in any way relieve the Contractor of responsibility for failure of the material or equipment, due to faulty design, material, or workmanship, to perform the functions required of them by the Specifications.

G-4.06 DELIVERY

The Contractor shall deliver materials in ample quantities to insure the most speedy and uninterrupted progress of the work so as to complete the work within the allotted time. The Contractor shall also coordinate deliveries in order to avoid a delay in, or impediment of, the progress of the work of any related Contractor.

G-4.07 CARE AND PROTECTION

The Contractor shall be solely responsible for properly storing and protecting all materials, equipment, and work furnished under the Contract from the time such materials and equipment are delivered at the site of the work until final acceptance thereof. He shall, at all times, take necessary precautions to prevent injury or damage by water, freezing, or by inclemencies of the weather to such materials, equipment and work. All injury or damage to materials, equipment, or work resulting from any cause whatsoever shall be made good by the Contractor.

The Engineer shall, in all cases, determine the portion of the site to be used by the Contractor for storage, plant or for other purposes. If, however, it becomes necessary to remove and restack materials to avoid impeding the progress of any part of the work or interference with the work to be done by any other Contractor, the Contractor shall remove and restack such materials at his own expense.

G-4.08 TOOLS AND ACCESSORIES

The Contractor shall, unless otherwise stated in the Contract Documents, furnish with each type, kind or size of equipment, one complete set of suitably marked high grade special tools and appliances which may be needed to adjust, operate, maintain, or repair the equipment. Such tools and appliances shall be furnished in approved painted steel cases, properly labeled and equipped with good grade cylinder locks and duplicate keys.

Spare parts shall be furnished as specified.

Each piece of equipment shall be provided with a substantial nameplate, securely fastened in place and clearly inscribed with the manufacturer's name, year of manufacture, serial number, weight and principal rating data.

G-4.09 INSTALLATION OF EQUIPMENT

The Contractor shall have on hand sufficient proper equipment and machinery of ample capacity to facilitate the work and to handle all emergencies normally encountered in work of this character.

Equipment shall be erected in a neat and workmanlike manner on the foundations at the locations and elevations shown on the Plans, unless directed otherwise by the Engineer during installation. All equipment shall be correctly aligned, leveled and adjusted for satisfactory operation and shall be installed so that proper and necessary connections can be made readily between the various units.

The Contractor shall furnish, install and protect all necessary anchor and attachment bolts and all other appurtenances needed for the installation of the devices included in the equipment specified. Anchor bolts shall be as approved by the Engineer and made of ample size and strength for the purpose intended. Substantial templates and working drawings for installation shall be furnished.

The Contractor shall, at his own expense, furnish all materials and labor for, and shall properly bed in non-shrink grout, each piece of equipment on its supporting base that rests on masonry foundations. Grout shall completely fill the space between the equipment base and the foundation.

G-4.10 OPERATING INSTRUCTIONS

The Contractor, through qualified individuals, shall adequately instruct designated employees of the City in the operation and care of all equipment installed hereunder, except for equipment that may be furnished by the City.

The Contractor shall also furnish and deliver to the Engineer three complete sets for permanent files, identified in accordance with Subsection G-3.01 hereof, of instructions, technical bulletins and any other printed matter, such as diagrams, prints or drawings, containing full information required for the proper operation, maintenance, and repair, of the equipment installed and the ordering of spare parts, except for equipment that may be furnished by the City.

In addition to the above three copies, the Contractor shall furnish any additional copies that may be required for use during construction and start-up operations.

G-4.11 SERVICE OF MANUFACTURER'S ENGINEER

The Contract prices for equipment shall include the cost of furnishing a competent and experienced engineer or superintendent who shall represent the manufacturer and shall assist the Contractor, when required, to install, adjust, test and place in operation the equipment in conformity with the Contract Documents. After the equipment is placed in

permanent operation by the City, such engineer or superintendent shall make all adjustments and tests required by the Engineer to provide that such equipment is in proper and satisfactory operating condition, and shall instruct such personnel as may be designated by the City in the proper operation and maintenance of such equipment.

SECTION 5 INSPECTION AND TESTING

G-5.01 GENERAL

The Contractor's attention is hereby directed to Article 3.03 of the Agreement.

Inspection and testing of materials will be performed by the City unless otherwise specified.

For tests specified to be made by the Contractor, the testing personnel shall make the necessary inspections and tests and the reports thereof shall be in such form as will facilitate checking to determine compliance with the Contract Documents. Five copies of the reports shall be submitted and authoritative certification thereof must be furnished to the Engineer as a prerequisite for the acceptance of any material or equipment.

If, in the making of any test of any material or equipment, it is ascertained by the Engineer that the material or equipment does not comply with the Contract, the Contractor will be notified thereof and he will be directed to refrain from delivering said material and equipment, or to remove it promptly from the site or from the work and replace it with acceptable material, without cost to the City.

Tests of electrical and mechanical equipment and appliances shall be conducted in accordance with recognized test codes of the ANSI, ASME, or the IEEE, except as may otherwise be stated herein.

The Contractor shall be fully responsible for the proper operation of equipment during tests and instruction periods and shall neither have nor make any claim for damage which may occur to equipment prior to the time when the City formally takes over the operation thereof.

G-5.02 COSTS

All inspection and testing of materials furnished under this Contract will be performed by the City or duly authorized inspection engineers or inspection bureaus without cost to the Contractor, unless otherwise expressly specified.

The cost of shop and field tests of equipment and of certain other tests specifically called for in the Contract Documents shall be borne by the Contractor and such costs shall be deemed to be included in the contract price.

Materials and equipment submitted by the Contractor as the equivalent to those specifically named in the Contract may be tested by the City for compliance. The Contractor shall reimburse the City for the expenditures incurred in making

such tests on materials and equipment which are rejected for noncompliance.

G-5.03 INSPECTIONS OF MATERIALS

The Contractor shall give notice, in writing to the Engineer, sufficiently in advance of his intention to commence the manufacture or preparation of materials especially manufactured or prepared for use in or as part of the permanent construction. Such notice shall contain a request for inspection, the date of commencement and the expected date of completion of the manufacture or preparation of materials. Upon receipt of such notice the Engineer will arrange to have a representative present at such times during the manufacture as may be necessary to inspect the materials or he will notify the Contractor that inspection will be made at a point other than the point of manufacture, or he will notify the Contractor that inspection will be waived. The Contractor must comply with these provisions before shipping any material. Such inspection shall not release the Contractor from the responsibility for furnishing materials meeting the requirements of the Contract Documents.

G-5.04 CERTIFICATE OF MANUFACTURE

When inspection is waived or when the Engineer so requires, the Contractor shall furnish to him authoritative evidence in the form of Certificates of Manufacture that the materials to be used in the work have been manufactured and tested in conformity with the Contract Documents. These certificates shall be notarized and shall include copies of the results of physical tests and chemical analyses, where necessary, that have been made directly on the product or on similar products of the manufacturer.

G-5.05 SHOP TESTS OF OPERATING EQUIPMENT

Each piece of equipment for which pressure, duty, capacity, rating, efficiency, performance, function, or special requirements are specified shall be tested in the shop of the maker in a manner which shall conclusively prove that its characteristics comply fully with the requirements of the Contract Documents. No such equipment shall be shipped to the work until the Engineer notifies the Contractor, in writing, that the results of such tests are acceptable.

Five copies of the manufacturer's actual test data and interpreted results thereof, accompanied by a certificate of authenticity sworn to by a responsible official of the manufacturing company, shall be forwarded to the Engineer for approval.

The cost of the shop tests and of furnishing manufacturer's preliminary and shop test data of operating equipment shall be borne by the Contractor.

G-5.06 PRELIMINARY FIELD TESTS

As soon as conditions permit, the Contractor shall furnish all labor, materials, and instruments and shall make preliminary field tests of equipment. If the preliminary field tests disclose any equipment furnished under this Contract which does not comply with the requirements of the Contract Documents, the Contractor shall, prior to the acceptance tests, make all changes, adjustments, and replacements required.

TEMPORARY STRUCTURES

G-5.07 FINAL FIELD TESTS

Upon completion of the work and prior to final payment, all equipment and appliances installed under this Contract shall be subjected to acceptance tests as specified or required to prove compliance with the Contract Documents.

The Contractor shall furnish labor, fuel, energy, water and all other materials, equipment, and instruments necessary for all acceptance tests, at no additional cost to the City.

G-5.08 FAILURE OF TESTS

Any defects in the materials and equipment or their failure to meet the tests, guarantees or requirements of the Contract Documents shall be promptly corrected by the Contractor by replacements or otherwise. The decision of the Engineer as to whether or not the Contractor has fulfilled his obligations under the Contract shall be final and conclusive. If the Contractor fails to make those corrections or if the improved materials and equipment, when tested, shall again fail to meet the guarantees or specified requirements, the City, notwithstanding its partial payment for work, and materials and equipment, may reject the materials and equipment and may order the Contractor to remove them from the site at his own expense.

In case the City rejects any materials and equipment, then the Contractor shall replace the rejected materials and equipment within a reasonable time. If he fails to do so, the City may, after the expiration of a period of thirty calendar days after giving him notice in writing, proceed to replace such rejected materials and equipment, and the cost thereof shall be deducted from any compensation due or which may become due the Contractor under this Contract.

The City agrees to obtain other equipment within a reasonable time and the Contractor agrees that the City may use the equipment furnished by him without rental or other charges until the new equipment is obtained.

Materials or work in place that fails to pass acceptability tests shall be retested at the direction of the construction engineer all such retests shall be at the Contractor's expense. The rates charged shall be in accordance with the Department of Public Works current annual inspection contract which is available for inspection at the offices of the Department of Public Works.

G-5.09 FINAL INSPECTION

The procedures for final inspection shall be in accordance with the provisions of Article 4.07 of the Agreement. During such final inspections, the work shall be clean and free from water. In no case will the final estimate be prepared until the Contractor has complied with all the requirements set forth and the Engineer has made his final inspection of the entire work and is satisfied that the entire work is properly and satisfactorily constructed in accordance with the requirements of the Contract Documents.

SECTION 6

G-6.01 GENERAL

All false work, scaffolding, ladders, hoistways, braces, pumping plants, shields, trestles, roadways, sheeting, centering forms, barricades, drains, flumes, and the like, any of which may be needed in the construction of any part of the work and which are not herein described or specified in detail, must be furnished, maintained and removed by the Contractor, and he shall be responsible for the safety and efficiency of such works and for any damages that may result from their failure or from their improper construction, maintenance, or operation.

G-6.02 PUBLIC ACCESS

At all points in the work where public access to any building, house, place of business, public road, or sidewalk would be obstructed by any action of the Contractor in executing the work required by this Contract, the Contractor shall provide such temporary structure, bridges or roadway as may be necessary to maintain public access at all times. At least one lane for vehicular traffic shall be maintained in streets in which the Contractor is working. Street closure permits are required from the Department of Public Works.

The Contractor shall provide suitable temporary bridges, as directed by the Engineer, at street intersections when necessary for the maintenance of vehicular and pedestrian traffic.

Prior to temporarily cutting of access to driveways and garages, the Contractor shall give twelve (12) hours notice to affected property owners. Interruptions to use of private driveways shall be kept to a minimum.

G-6.03 CONTRACTOR'S FIELD OFFICE

The Contractor shall erect, furnish and maintain a field office with a telephone at the site during the entire period of construction. He or an authorized agent shall be present at this office at all times while his work is in progress. Readily accessible copies of both the Contract Documents and the latest approved working drawings shall be kept at this field office.

G-6.04 TEMPORARY FENCE

If, during the course of the work, it is necessary to remove or disturb any fence or part thereof, the Contractor shall, at his own expense, if so ordered by the Engineer, provide a suitable temporary fence which shall be maintained until the permanent fence is replaced. The Engineer shall be solely responsible for the determination of the necessity for providing a temporary fence and the type of temporary fence to be used.

G-6.05 RESPONSIBILITY FOR TEMPORARY STRUCTURES

In accepting the Contract, the Contractor assumes full responsibility for the sufficiency and safety of all temporary structures or work and for any damage which may result from their failure or their improper construction, maintenance, or operation and will indemnify and save harmless the City from

all claims, suits or actions and damages or costs of every description arising by reason of failure to comply with the above provisions.

SECTION 7 TEMPORARY SERVICES

G-7.01 WATER

The Contractor shall provide the necessary water supply at his own expense. He shall, if necessary, provide and lay necessary waterlines from existing mains to the place of using, shall secure all necessary permits and pay for all taps to water mains or hydrants and for all water used at the established rates.

G-7.02 LIGHT AND POWER

The Contractor shall provide, at his own expense, temporary lighting and power facilities required for the proper prosecution and inspection of the work. If, in the opinion of the Engineer, these facilities are inadequate, the Contractor will not be permitted to proceed with any portion of the work affected thereby.

G-7.03 SANITARY REGULATIONS

The Contractor shall prohibit and prevent the committing of nuisances on the site of the work or on adjoining property and shall discharge any employee who violates this rule.

Ample washrooms and toilet facilities and a drinking water supply shall be furnished and maintained in strict conformity with the law by the Contractor for use by his employees.

G-7.04 ACCIDENT PREVENTION

Precautions shall be exercised at all times for the protection of persons and property. The safety provisions of applicable laws, building and construction codes shall be observed. The Contractor shall comply with the U. S. Department of Labor Safety and Health Regulations for construction promulgated under the Occupational Safety and Health Act of 1970 (PL 91-596), and under Section 107 of the Contract Work. Hours and Safety Standards Act (PL 91-54), except where state and local safety standards exceed the federal requirements and except where state safety standards have been approved by the Secretary of Labor in accordance with provisions of the Occupational Safety and Health Act.

G-7.05 FIRST AID

The Contractor shall keep upon the site, at each location where work is in progress, a completely equipped first aid kit and shall provide ready access thereto at all times when men are employed on the work.

G-7.06 HEATING

The Contractor shall provide temporary heat, at his own expense, whenever required on account of work being carried on during cold weather and to prevent freezing of water pipes and other damage to the work.

SECTION 8

LINES AND GRADES

G-8.01 GENERAL

All work done under this Contract shall be constructed in accordance with the lines and grades shown on the Plans, or as given by the Engineer. The full responsibility for keeping alignment and grade shall rest upon the Contractor.

The Engineer will establish bench marks and base line controlling points. Reference remarks for lines and grades as the work progresses will be located to cause as little inconvenience to the prosecution of the work as possible. The Contractor shall so place excavation and other materials as to cause no inconvenience in the use of the use of the reference marks provided. He shall remove any obstructions placed by him contrary to this provision.

G-8.02 SURVEYS

The Contractor shall furnish and maintain, at his own expense, stakes and other such materials, and give such assistance, including qualified helpers, as may be required by the Engineer for setting reference marks. The Contractor shall check such reference marks by such means as he may deem necessary and, before using them, shall call the Engineer's attention to any inaccuracies. The Contractor shall, at his own expense, establish all working or construction lines and grades as required from the reference marks set by the Engineer, and shall be solely responsible for the accuracy thereof. He shall, however, be subject to the check and review of the Engineer.

The Contractor shall keep the Engineer informed a reasonable time in advance as to his need for line and grade reference marks, in order that they may be furnished and all necessary measurements made for record and payment with the minimum of inconvenience to the Engineer or of delay to the Contractor.

It is the intention not to delay the work for the establishment of reference marks but, when necessary, working operations shall be suspended for such reasonable time as the Engineer may require for this purpose.

G-8.03 SAFEGUARDING MARKS

The Contractor shall safeguard all points, stakes, grade marks, monuments and bench marks made or established on the work, bear the cost of reestablishing them if disturbed, and bear the entire expense of rectifying work improperly installed due to not maintaining or protecting or to removing without authorization such established points, stakes and marks.

The Contractor shall safeguard all existing and known property corners, monuments and marks adjacent to but not related to the work and, if required, shall bear the cost of reestablishing them if disturbed or destroyed.

G-8.04 DATUM PLANE

All elevations indicated or specified refer to the Mean Sea Level Datum of the U.S.C. & G.S. (N.O.S.) which is 0.80 feet above the Mean Low Water Datum of the U. S. Army

Corps of Engineers.

SECTION 9 ADJACENT STRUCTURES AND LANDSCAPING

G-9.01 RESPONSIBILITY

The responsibility for removal, replacement, relocation, repair, rebuilding or protection of all public utility installations, including poles, tracks, pipes, wires, conduits, house service connections, vaults, manholes, sewers, traffic control and fire alarm signal circuit installations and other appurtenances and facilities shall be in accordance with G-1.02 and G-1.03.

The Contractor shall also be entirely responsible and liable for all damage or injury as a result of his operations to all other adjacent public and private property, structures of any kind and appurtenances thereto met with during the progress of the work. The cost of protection, replacement in their original locations and conditions or payment of damages for injuries to such adjacent public and private property and structures affected by the work, whether or not shown on the Plans, and the removal, relocation, and reconstruction of such items called for on the Plans or specified shall be included in the various Contract Items and no separate payment will be made therefor. Where such public and private property, structures of any kind and appurtenances thereto are not shown on the Plans and when, in the opinion of the Engineer, removal or relocation and reconstruction is necessary to avoid interference with the work, payment therefor will be made as provided for extra work in Article 7.02 of the Agreement.

G-9.02 PROTECTION OF TREES

All trees and shrubs shall be adequately protected by the Contractor with boxes or otherwise and, within the City of Tampa, in accordance with ordinances governing the protection of trees. No excavated materials shall be placed so as to injure such trees or shrubs. Trees or shrubs destroyed by negligence of the Contractor or his employees shall be replaced by him with new stock of similar size and age, at the proper season, and at the sole expense of the Contractor.

Beneath trees or other surface structures, where possible, pipelines may be built in short tunnels, backfilled with excavated materials, except as otherwise specified, or the trees or structures carefully supported and protected from damage.

The City may order the Contractor, for the convenience of the City, to remove trees along the line of trench excavation. If so ordered, the City will obtain any permits required for removal of trees. Such tree removal ordered shall be paid for under the appropriate Contract Items.

G-9.03 LAWN AREAS

Lawn areas shall be left in as good condition as before the starting of the work. Where sod is to be removed, it shall be carefully removed and later replaced, or the area where sod has been removed shall be restored with new sod in the

manner described in the Technical Specifications section.

G-9.04 RESTORATION OF FENCES

Any fence, or part thereof, that is damaged or removed during the course of the work shall be replaced or repaired by the Contractor and shall be left in as good a condition as before the starting of the work. The manner in which the fence is repaired or replaced and the materials used in such work shall be subject to the approval of the Engineer. The cost of all labor, materials, equipment, and work for the replacement or repair of any fence shall be deemed included in the appropriate Contract Item or Items, or if no specific Item is provided therefor, as part of the overhead cost of the work, and no additional payment will be made therefor.

SECTION 10 PROTECTION OF WORK AND PUBLIC

G-10.01 TRAFFIC REGULATIONS

The Contractor shall arrange his work to comply with Article G-6.02. The work shall be done with the least possible inconvenience to the public and to that end the work may be confined by the Engineer to one block at a time.

G-10.02 BARRIERS AND LIGHTS

During the prosecution of the work, the Contractor shall put up and maintain at all times such barriers, and lights, as will effectually prevent accidents. The Contractor shall provide suitable barricades, red lights, "danger" or "caution" or "street closed" signs and watchmen at all places where the work causes obstructions to the normal traffic or constitutes in any way a hazard to the public. Such barriers and signs shall be constructed to State of Florida Department of Transportation standards and placed as recommended by the Traffic Division of the City's Department of Public Works.

No open fires will be permitted.

G-10.03 SMOKE PREVENTIONS

The Contractor shall use hard coal, coke, oil or gas as fuel for equipment generating steam. A strict compliance with ordinances regulating the production and emission of smoke will be required.

G-10.04 NOISE

The Contractor shall eliminate noise to as great an extent as practicable at all times. Air compressing plants shall be equipped with silencers and the exhaust of all gasoline motors or other power equipment shall be provided with mufflers. In the vicinity of hospitals and schools, special care shall be used to avoid noise or other nuisances. The Contractor shall strictly observe all local regulations and ordinances covering noise control.

Except in the event of an emergency, no work shall be done between the hours of 7:00 p.m. and 7:00 a.m., or on Sundays.

If the proper and efficient prosecution of the work requires operations during the night, the written permission of the Engineer shall be obtained before starting such items of the work.

**SECTION 13
CLEANING**

G-10.05 ACCESS TO PUBLIC SERVICES

Neither the materials excavated nor the materials or plant used in the construction of the work shall be so placed as to prevent free access to all fire hydrants, valves or manholes.

G-10.06 DUST PREVENTION

The Contractor shall prevent dust nuisance from his operations or from traffic by keeping the streets sprinkled with water at all times.

G-10.07 PRIVATE PROPERTY

The Contractor shall so conduct the work that no equipment, material, or debris will be placed or allowed to fall upon private property in the vicinity of the work unless he shall have obtained the owner's written consent thereto and shall have shown this consent to the Engineer.

**SECTION 11
SLEEVES AND INSERTS**

G-11.01 COORDINATION

When the Contract requires the placing of conduits, saddles, boxes, cabinets, sleeves, inserts, foundation bolts, anchors, and other like work in floors, roofs, or walls of buildings and structures, they shall be promptly installed in conformity with the construction program. The Contractor who erects the floors, roofs, and walls shall facilitate such work by fully cooperating with the Contractors responsible for installing such appurtenances. The Contractor responsible for installing such appurtenances shall arrange the work in strict conformity with the construction schedule and avoid interference with the work of other contractors.

G-11.02 OPENINGS TO BE PROVIDED

In the event timely delivery of sleeves and other materials cannot be made and to avoid delay, the affected Contractor may arrange to have boxes or other forms set at the locations where the appurtenances are to pass through or into the floors, roofs, walls, or other work. Upon the subsequent installation of these appurtenances, the Contractor erecting the structure shall fill around them with materials as required by the Contract. The necessary expenditures incurred for the boxing out and filling in shall be borne by the Contractor or Contractors required to furnish the sleeves and inserts. Formed openings and later installation of sleeves will not be permitted at locations subject to hydrostatic pressure.

**SECTION 12
CUTTING AND PATCHING**

G-12.01 GENERAL

The Contractor shall do all cutting, fitting, or patching of his portion of the work that may be required to make the several parts thereof join and coordinate in a manner satisfactory to the Engineer and in accordance with the Plans and Specifications. The work must be done by competent workmen skilled in the trade required by the restoration.

G-13.01 DURING CONSTRUCTION

During construction of the work, the Contractor shall, at all times, keep the site of the work and adjacent premises as free from material, debris, and rubbish as is practicable and shall remove the same from any portion of the site if, in the opinion of the Engineer, such material, debris, or rubbish constitutes a nuisance or is objectionable.

The Contractor shall remove from the site all of his surplus materials and temporary structures when no further need therefor develops.

G-13.02 FINAL CLEANING

At the conclusion of the work, all erection plant, tools, temporary structures and materials belonging to the Contractor shall be promptly taken away, and he shall remove and promptly dispose of all water, dirt, rubbish or any other foreign substances.

The Contractor shall thoroughly clean all equipment and materials installed by him and shall deliver such materials and equipment undamaged in a bright, clean, polished, and new appearing condition.

**SECTION 14
MISCELLANEOUS**

G-14.01 PROTECTION AGAINST SILTATION AND BANK EROSION

The Contractor shall arrange his operations to minimize siltation and bank erosion on construction sites and on existing or proposed watercourses and drainage ditches.

G-14.02 EXISTING FACILITIES

The work shall be so conducted to maintain existing facilities in operation insofar as is possible. Work shall be scheduled to minimize bypassing during construction. Requirements and schedules of operations for maintaining existing facilities in service during construction shall be as described in the Special Provisions.

G-14.03 USE OF CHEMICALS

All chemicals used during project construction or furnished for project operation, whether herbicide, pesticide, disinfectant, polymer, reactant or of other classification, must show approval of either EPA or USDA. Use of all such chemicals and disposal of residues shall be in strict conformance with instructions.



Page 1 of 2 –DMI Payment
City of Tampa – DMI Sub-(Contractors/Consultants/Suppliers) Payments
(FORM MBD-30)

[] Partial [] Final

Contract No.: _____ WO#,(if any): _____ Contract Name: _____

Contractor Name: _____ Address: _____

Federal ID: _____ Phone: _____ Fax: _____ Email: _____

GC Pay Period: _____ Payment Request/Invoice Number: _____ City Department: _____

Total Amount Requested for pay period: \$ _____ Total Contract Amount(including change orders):\$ _____

Type of Ownership - (F=Female M=Male), BF BM = African Am., HF HM = Hispanic Am., AF AM = Asian Am., NF NM = Native Am., CF CM = Caucasian S = SLBE

| Type | Trade/Work Activity | Total Sub Contract Or PO Amount | Amount Paid To Date | Amount To Be Paid For This Period |
|-----------------------|---------------------|---------------------------------|------------------------------------|-----------------------------------|
| []Sub []Supplier | | | Amount Pending Previously Reported | Sub Pay Period Ending Date |
| Federal ID | | | | |
| | | | \$ | \$ |
| | | | | |
| | | | \$ | \$ |
| | | | | |
| | | | \$ | \$ |
| | | | | |
| | | | \$ | \$ |
| | | | | |
| | | | \$ | \$ |
| | | | | |
| | | | \$ | \$ |
| | | | | |

(Modifying This Form or Failure to Complete and Sign May Result in Non-Compliance)

Certification: I hereby certify that the above information is a true and accurate account of payments to sub – contractors/consultants on this contract.

Signed: _____ Name/Title: _____ Date: _____



Page 2 of 2 – DMI Payment

Instructions for completing The DMI Sub-(Contractors/Consultants/ Suppliers) Payment Form (Form MBD-30)

This form must be submitted with all invoicing or payment requests where there has been subcontracting rendered for the pay period. If applicable, after payment has been made to the subcontractor, “Waiver and Release of Lien upon Progress Payment”, “Affidavit of Contractor in Connection with Final Payment”, or an affidavit of payment must be submitted with the amount paid for the pay period. The following will detail what data is required for this form. The instructions that follow correspond to the headings on the form required to be completed. **(Modifying or omitted information from this form my result in non-compliance).**

- **Contract No.** This is the number assigned by the City of Tampa for the bid or proposal.
- **W.O.#** If the report covers a work order number (W.O.#) for the contract, please indicate it in that space.
- **Contract Name.** This is the name of the contract assigned by the City of Tampa for the bid or proposal.
- **Contractor Name.** The name of your business.
- **Address.** The physical address of your business.
- **Federal ID.** A number assigned to a business for tax reporting purposes.
- **Phone.** Telephone number to contact business.
- **Fax.** Fax number for business.
- **Email.** Provide email address for electronic correspondence.
- **Pay Period.** Provide start and finish dates for pay period. (e.g. 05/01/13 – 05/31/13)
- **Payment Request/Invoice Number.** Provide sequence number for payment requests. (ex. Payment one, write 1 in space, payment three, write 3 in space provided.)
- **City Department.** The City of Tampa department to which the contract pertains.
- **Total Amount Requested for pay period.** Provide all dollars you are expecting to receive for the pay period.
- **Total Contract Amount (including change orders).** Provide expected total contract amount. This includes any change orders that may increase or decrease the original contract amount.
- **Signed/Name/Title/Date.** This is your certification that the information provided on the form is accurate.
- **See attached documents.** Check if you have provided any additional documentation relating to the payment data. Located at the bottom middle of the form.
- **Partial Payment.** Check if the payment period is a partial payment, not a final payment. Located at the top right of the form.
- **Final Payment.** Check if this period is the final payment period. Located at the top right of the form.

The following instructions are for information of any and all subcontractors used for the pay period.

- **(Type) of Ownership.** Indicate the Ethnicity and Gender of the owner of the subcontracting business or SLBE.
- **Trade/Work Activity.** Indicate the trade, service, or material provided by the subcontractor.
- **SubContractor/SubConsultant/Supplier.** Please indicate status of firm on this contract.
- **Federal ID.** A number assigned to a business for tax reporting purposes. This information is critical in proper identification of the subcontractor.
- **Company Name, Address, Phone & Fax.** Provide company information for verification of payments.
- **Total Subcontract Amount.** Provide total amount of subcontract for subcontractor including change orders.
- **Amount Paid To Date.** Indicate all dollars paid to date for the subcontractor.
- **Amount Pending, Previously Reported.** Indicate any amount previously reported that payments are pending.
- **Amount To Be Paid for this Period.** Provide dollar amount of dollars requested for the pay period.
- **Sub Pay Period Ending Date.** Provide date for which subcontractor invoiced performed work.

Forms must be signed and dated or will be considered incomplete. The company authorized representative must sign and certify the information is true and accurate. Failure to sign this document or return the document unsigned can be cause for determining a company is in non-compliance of Ordinance 2008-89.

If any additional information is required or you have any questions, you may call the Minority Business Development Office at (813) 274-5522.

SPECIFIC PROVISIONS

S1.0 GENERAL

The Specific Provisions are intended as modifications or supplements to Instructions to Bidders, General Provisions and Agreement.

This is a one year contract for the City of Tampa's Water Department for roadway, driveway, sidewalk and sod restoration. The work will be located in many portions of the City's service area and will be given out to the Contractor from time to time as individual projects. Restorations may not include plans, but may require rights-of-way permits and maintenance of traffic. If the project is a work order with County or FDOT permit, then plans may be provided for that work. The Contractor is still required to obtain an approved Traffic Control Plan with the R/W agency.

The City of Tampa reserves the right to require the Contractor to change his "Contractor Superintendent" at any time.

S2.0 DEFINITIONS

Add or amend the Definitions in Article 1.02 of the Agreement to these documents as follows:

"Department"

Add the following: "Whenever the word "Department" is used in these Documents, it shall mean the "City of Tampa Water Department".

"Owner" as it is referred to in the Technical Specifications shall mean the City of Tampa Water Department.

S3.0 APPLICABLE CODES OR STANDARDS

When words that have a well known technical or trade meaning are used to describe work, materials or equipment, such words shall be interpreted in accordance with such meaning.

When reference is made to codes or standards of organizations as outlined in Section G-4.03 of the General Provisions, it shall mean the latest revision thereof. However, no provision of any reference standard specification, manual or code (whether or not specifically incorporated by reference in the Contract Documents) shall change the duties and responsibilities of the City, Engineer or Contractor, or any of their agents or employees from those set forth in the Contract Documents.

S4.0 PERIOD OF CONTRACT

Unless prior notice to the contrary is given to the Contractor by the Department, this contract shall be in full force and effect starting on the date of the contract and continuing for 365 consecutive calendar days. However, this contract can be renewed, upon the same prices, terms, and conditions, for 2 additional 1-year periods, if agreeable with both parties and if funds are available.

To renew the contract for an additional 1 year period the Contractor must notify the City, in writing that he desires renewal of the contract and present a new Performance Bond and Payment Bond to cover the new period. The letter must be received by the City at least 120 days prior to contract expiration. The City shall respond to the Contractor's renewal request at least 90 days prior to the contract expiration.

S4.1 BASIS OF AWARD/CONTRACT PRICE

The Contract will be awarded, if at all, to the lowest responsible bidder. The City reserves the right to reject any and all bids where in the opinion of the City, the bid is excessively high or otherwise would not be in the City's best interest.

The City reserves the right to assign quantities of work to the contractor based on performance criteria, including but not necessarily limited to, the ability to meet acceptable schedules, the ability to satisfactorily complete leakage/pressure tests, other construction testing and timeliness of satisfactory restoration.

S4.2 TIME PROVISIONS

“Within 5 days after Notice to Proceed but before Contractor starts work at the site, a conference attended by Contractor, Engineer and other as appropriate may be held to discuss: (1) the schedules referred to in Paragraph Preliminary Schedules herein; (2) procedures for handling shop drawings and other submittals; (3) procedures for processing Application for Payment; and (4) to establish a working understanding among the parties to the work.

The Contractor shall be required to maintain schedule in keeping with the requirements of the Water Department staff and regulatory agencies. The Contractor shall have the following time line to complete work from the notice to proceed or as stated:

State Project restoration shall be completed the same day the work is finished.

Street Restoration 7 days

Sidewalk Restoration 7 days

Driveways and Parking lots 7 days

S5.0 LICENSES AND PERMITS

If not previously acquired by the Department, the Contractor must obtain at his own expense, right-of-way permits, licenses, or other legal authorization necessary for the execution of each project issued by the Department. Where applicable (project/work order results in one acre or more of disturbed earth) the Contractor shall file a Notice of Intent (NOI) to access the generic NPDES permit administered by the Florida Department of Environmental Protection (FDEP). All document preparation, monitoring, reporting and other compliance with the NOI requirements shall be the responsibility of the Contractor and no separate payment shall be made. The Contractor must comply with all regulations, building and construction codes as may be required by law. Copies of all permits must be kept at the job site during construction. The Contractor

shall comply with all the terms and requirements of the permits and will be held liable for the violation of any and all such permits.

S6.0 LIQUIDATED DAMAGES

Due to the nature of the project, liquidated damages may be assessed. The Contractor will be given a reasonable length of time, as defined as a notification for each project. The Contractor shall complete the work expeditiously, including proper clean up, within that length of time. If a project is not completed within the time allotted, then the Department may deduct liquidated damages from the Contractor's payment for project. Liquidated damages are \$250.00 per day for each calendar day that the work exceeds the allotted completion time.

Payment will not be processed prior to final walk inspection and acceptance by the Engineer.

S7.0 WORK DIRECTIVE CHANGE

A Work Directive Change is a written directive to the Contractor, issued on or after the date of the execution of the Agreement, and signed by the Engineer on behalf of the City, ordering an addition, deletion or revision in the work, or responding to an emergency. A Work Directive Change will not change the contract price or the time for completion, but is evidence that the parties expect that the change directed or documented by a Work Directive Change will be incorporated in a subsequently issued Change Order following negotiations by the parties as to its effect, if any, on the contract price or the time of completion.

Without invalidating the Agreement, additions, deletions or revisions in the work may, at any time or from time to time, be authorized by a Change Order or a Work Directive Change. Upon receipt of any such document, the Contractor shall promptly proceed with the work involved.

S8.0 DEFECTIVE MATERIALS

Contractor must haul materials in a safe and careful manner to avoid possible damage. Should any damage be done, the Contractor shall be fully responsible. No materials may be stored along the installation routes.

The Contractor shall maintain record of concrete and asphalt mixes delivered to the work sites.

S9.0 WORK PERFORMED ON SATURDAYS, SUNDAYS, LEGAL HOLIDAYS, OR AFTER REGULAR WORKING HOURS

The work shall normally be discontinued on Saturdays, Sundays, all City and State designated holidays, and after regular working hours (7:30 A.M. to 4:00 P.M., Monday through Friday). Due to the work schedules of the City forces who may be involved, all work shall be conducted during normal work hours and days (Monday through Friday and prior authorization must be requested by the Contractor for any work he feels is necessary to be accomplished on Saturdays, Sundays, or Holidays. Any overtime for the Contractor's convenience, weekend or holiday work requiring City forces will require reimbursement to the City by the Contractor for the cost of City Inspection

time required. The Contractor must request permission in writing at least 2 working days prior in order to perform work beyond regular work hours or on weekends or holidays as stated above. Written approval must be obtained from the Engineer.

When night work has been approved or directed by the Engineer, it shall be the responsibility of the Contractor to provide adequate artificial lighting at no cost to the City if the work is being done at the Contractor's request. The Contractor shall be responsible for the safety of all employees during night work.

S10.0 CONFLICTS WITH PROPOSED WORK

It shall be the Contractor's responsibility to alert the Engineer, at least two working days in advance of construction, to any conflicts or potential conflicts with the proposed work, including but not limited to conflicts with existing utilities. Failure of the Contractor to review the job site and alert the Engineer to any conflicts shall relieve the Department from compensating the Contractor for any cost arising from any remedial action necessary to resolve conflict with the proposed work.

S11.0 TEMPORARY FACILITIES AND CONTROLS

A) Temporary Water Supply

In lieu of the requirements outlined in Article G-7.01 of the General Provisions, all reasonable amounts of water required by the Contractor for the construction under this Agreement will be furnished by the City from the existing water system without cost to the Contractor. The Contractor shall request temporary hydrant meters (at no charge to the Contractor) with backflow prevention devices when connecting to existing water system hydrants. The Contractor shall make any necessary water supply connections at his own expense at a point designated by the City.

These connections shall be maintained by the Contractor, who shall furnish all pipe, valves, and such other equipment necessary or required. Temporary piping may run above ground when there is no possibility of traffic, and it can be done safely. Otherwise, it must run underground and in such manner as to meet the approval of the City. No water shall be wasted.

At the discretion of the City, unnecessary waste of water after notification will be cause for use of water to be discontinued. After temporary lines have served their purpose, they shall be removed by the Contractor and all connections closed or plugged to the satisfaction of the City.

B) Temporary Sanitary Facilities

Necessary sanitary conveniences for the use of all employees shall be erected and maintained in a satisfactory and sanitary condition, free from nuisance, by the Contractor at locations satisfactory to the Engineer, and their use shall be strictly enforced. Upon completion of the work they shall be removed leaving the premises clean.

C) Temporary Traffic Control

The Contractor shall arrange his work in order to obstruct traffic as little as possible. Maintenance of traffic shall conform to the requirements of Articles G-10.01 and 10.02 of the General Provisions and all requirements stated herein. All applicable Federal, State, Local regulations and permit conditions will be adhered to.

To protect persons from injury and to avoid property damage, adequate barrier walls, barricades, construction signs, torches, flashers, and guards as required shall be placed and maintained during the progress of the construction work and until it is safe to use the construction area for its normal purposes. Whenever required, the Contractor shall provide a watchman to prevent accidents. Rules and regulations of Local, State and Federal authorities in regard to safety provisions shall be observed. In addition, the installation of all mains and appurtenances shall comply with all requirements of the Occupational Safety and Health Administration (OSHA). The safety of the public and the work crews must be considered at all times. Because of the numerous conditions that must be considered, special traffic control planning must be made for each area within the construction limits.

In the absence of other regulatory requirements, the traffic control devices, the arrangement or position of the devices and the distances of the devices must be in conformance with the policies, procedures and regulations of the regulatory authority in charge of the right-of way or Part VI of the Manual on Uniform Traffic Control Devices (MUTCD), as a minimum standard. In FDOT rights-of-way, the MUTCD, the "Standard Specifications for Road and Bridge Construction" and the "FDOT Roadway and Traffic Design Standards for Design, Construction, Maintenance and Utility Operations on the State Highway System" shall be used. The Contractor shall not use fewer control devices, or reduce the signing, barricading or coning distances, to below these Minimum Standards. The Contractor is expected to expand or improve the installation whenever the need is indicated. Traffic movement through the work site is to be observed, and maintenance of all traffic control devices is expected during the construction period.

Prior to commencing work, the Contractor shall obtain permission from the appropriate Federal, State or local agency before construction starts and before making full or partial street closures, if such is allowed. When the appropriate agency requires plans for maintenance of traffic, the Contractor shall provide the necessary plans to the agency and to the Engineer. The Contractor will be responsible for the re-routing of all traffic occasioned by the closure and will provide all necessary barricades, guards, signs, etc. If it becomes necessary to block vehicular or pedestrian access to private property, the Contractor shall prior to proceeding with the excavation, make arrangements acceptable with the owners or occupants and the Engineer.

S12.0 MAINTENANCE AND RESTORATION OF JOB SITE

The Contractor shall conduct his operations in such a manner that will result in a minimum of inconvenience to occupants of adjacent homes and business establishments and shall provide temporary access as directed or as conditions in any particular location may require as determined by the Engineer. All restoration must be performed to an equal or better condition than that which existed prior to construction.

Good housekeeping on this project is extremely important and the Contractor will be responsible for keeping the construction site neat and clean, with debris being removed daily as the work progresses or as otherwise directed by the Engineer. Good housekeeping at the job site shall include: removing all tools and temporary structures, dirt, rubbish, etc.; hauling all excess dirt, rock, etc. from excavations to a dump provided by the Contractor; and all clean-up shall be accomplished to the satisfaction of the Engineer. Immediately after restoration is completed in an area or part thereof, barricades, construction equipment and surplus and discarded materials shall be removed by the Contractor.

In the event that the timely clean-up and restoration of the job site is not accomplished to the satisfaction of the Engineer, the Engineer may make arrangements to effect the necessary clean-up by others. The Contractor shall be back-charged for these costs. If such action becomes necessary on the part of and in the opinion of the Engineer, the Department shall not be responsible for the inadvertent removal from the work site of materials which the Contractor would not normally have disposed of had he affected the required clean-up.

The Contractor shall replace all open cut road pavements with a temporary compacted surface capable of supporting sustained vehicular loads as soon as possible once the trench or pit has been filled and compacted in 6-inch lifts. The temporary surface shall be maintained by the Contractor at the elevation of the adjacent road surfaces.

The Contractor is responsible for the security of all tools, materials and equipment required for this project and must make all arrangements for safeguards he may deem necessary. The City will assume no liability for any such security or losses resulting from lack of security.

S13.0 USE OF EXPLOSIVES

Explosives will not be used on the work except when authorized by the Engineer. If authorized, the use of explosives shall conform to laws or ordinances which may pertain to the use of same, and the utmost care will be exercised by the Contractor so as not to endanger life or property. The Contractor will assume full responsibility in connection with the use of any explosives even though authorized. Explosives will not be stored within City limits.

S14.0 GRADES AND DRAINAGE AT STREET INTERSECTIONS

The Contractor shall pay careful attention to the proper reconstruction of the pavement adjacent to the gutters and at street intersections to obtain satisfactory drainage to the inlets from the intersecting streets.

S15.0 ENVIRONMENTAL PROTECTION

The Contractor will be held liable for the violation of any and all environmental regulations and permit conditions. . Violation citations related to environmental regulations and permit conditions carry civil penalties and, in the event of willful violation, criminal penalties. The fact that the permits are issued to the City does not relieve the Contractor in any way of his environmental obligations and responsibilities.

The Contractor shall evaluate and assess the impact of any adverse effects on the natural environment which may result from construction operations and shall operate to minimize pollution of air, ground or surface waters and vegetation and afford the neighboring community the maximum protection during and upon completion of the construction. The Contractor shall comply with Article 14.01 of the General Provisions and submit a plan to the Engineer for review and acceptance prior to implementation of the plan. Such plan can be combined with other control plan submittals and shall address protective measures to be taken along the route during pipeline construction.

The Contractor shall take sufficient precautions to prevent pollution of streams, lakes, ponds and other water sources with fuels, oils, bitumen, calcium hypochlorite (HTH) or other harmful materials. He shall conduct and schedule his operations so as to avoid pollution or siltation of streams, lakes, etc., including the use of silt barriers, straw bales or other related control methods, as outlined in the FDOT Standard Specifications. Where there is a high potential for erosion, the Contractor shall not expose, by construction operations, a larger area of erosive land at any one time than the minimum necessary for efficient construction operations, and the duration of exposure of the uncompleted construction to the elements shall be as short as practicable. Erosion control features shall be constructed concurrently with other work and at the earliest practicable time.

S16.0 USE OF PRIVATE PROPERTY

In accordance with Section 10, Paragraph G-10.07 of the General Provisions, all construction activities required to complete this project in accordance with the plans and specifications shall be confined to public rights-of-way, unless the Contractor makes specific arrangements with private property owners for his use of their property. The City assumes no responsibility for damage to private property in such instances. The Contractor is responsible for protection of private property abutting the work areas on this project.

S17.0 TREE PROTECTION

The Contractor shall be extremely careful and make all efforts to preserve existing trees, plants, and shrubs within the construction area.

S18.0 STANDARD DETAILS

In addition to the various details applicable to the project included in the plans, there are Standard Details of the City of Tampa Water Department that shall apply to this work. The details that are to supplement those shown in the plans are included herein.

S19.0 WORKER SAFETY

The Contractor shall comply with all requirements in OSHA 29 CFR 1910.146 and FAC 38I 20.035 for confined spaces and confined space entry.

S20.0 CONTRACTOR’S PRESENCE

The Contractor or his authorized representative shall be present at the job site at all times while the work is in progress. Readily accessible copies of both the Contract Documents shall be kept at the job site.

S21.0 EMERGENCY MOBILIZATION

No mobilization fee will be allowed for projects with start times greater than 48 hours. The projects for this contract are specifically to supplement City Crews with roadway, sidewalk, driveway and sod restorations. The Contractor should expect to have crews available to notify Florida One Call Center, acquire permits and start work at a job site within 7 working days from the beginning of the project. Longer times may be allowed if a project has substantial permitting requirements. Work within the City of Tampa requires permitting by the Contractor. No permit fees will be assessed; however Traffic Control will be the responsibility of the Contractor. Permits for work in Hillsborough County and FDOT rights-of-way are taken out by the City. The Contractor is responsible to submit Traffic Control Plans per agency requirements and maintain the devices for the duration of the project.

Emergency projects are those requiring less than 48 hours response times. The Contractor is allowed a mobilization fee for such projects. These projects are usually done with the City coordinating with the right-of-way agency to restore roadways in a short time frame.

CONTRACT PAY ITEMS

C1.00 General

The Contractor shall receive and accept the compensation provided in the Proposal and the Agreement as full payment for furnishing all labor, tools and equipment, for performing all operations necessary to complete the work under the Agreement, and also in full payment for all loss or damages arising from the nature of the work, or from any discrepancy between the actual quantities of work and quantities herein estimated by the Engineer, or from the action of the elements or from any unforeseen difficulties which may be encountered during the prosecution of the work until the final acceptance by the Department.

It is the intent of these contract documents that any cost for which compensation is not directly provided by a bid item shall be prorated and included in the bid item for which they are required. Failure of the Contractor to follow this procedure shall be basis for rejection of his bid.

The prices stated in the Proposal include all costs and expenses for taxes, labor, equipment, commissions, transportation charges and expenses, patent fees and royalties, labor for handling material during inspection together with any and all other costs and expenses for performing and completing the work as shown on the plans and specified herein. The basis of payment for any item at the unit price shown in the Proposal shall be in accordance with the description of that item in this Section.

No separate payment will be made for the following items. The cost of such work shall be included in the applicable contract pay items of work, including separate mobilization/ demobilization charges for compliance with Local, State or Federal agencies.

1. Mobilization is included in the work items except for emergency mobilizations;
2. Site preparation;
3. Excavation, including necessary pavement/slab removal;
4. Backfill and proper compaction, including suitable fill.
5. Grading;
6. Replacement or restoration of paved or unpaved roadways, grass and shrubbery plots outside of established pay limits;
7. Temporary facilities and controls during construction such as water/sanitary facilities, traffic control, informational signs and environmental protection, unless specifically provided for in a pay item;
8. Removing and disposing of waste material due to construction;
9. Any material and equipment required to be installed and used for the tests.
10. Maintaining the existing quality of service during construction.
11. Adjusting new or existing water meter boxes to grade which are affected by construction.
12. Coordination with all Federal, State and Local agencies.

All work shall be in accordance with the Technical Specifications and Standard Details herein. All materials shall be in accordance with the Material Specifications herein.

C2.00 Restoration and Incidental Items

C2.10 General

The Contractor shall furnish all labor, equipment, and materials to restore the construction area to an equal or better condition than that which existed prior to construction.

C2.20 Pavement

The Contractor shall provide all labor, equipment and materials to remove and restore pavement and pavement bases that were cut and removed during the course of the pipeline construction. Pavement and pavement base restoration shall include roadways, driveways, parking lots, etc.

Whenever water main work is performed by City Crews, the trench will be backfilled and compacted with density tests done by the City. The Contractor shall saw cut the trench if needed and add the asphalt or driveways as stated below. Once on-site, the Contractor will maintain existing traffic control devices and/or replace devices as needed.

Under this section, payment shall be made for:

1. Furnishing, placing, grading, and compacting various thicknesses of approved lime rock base;
2. Furnishing, placing, grading, and compacting various thicknesses of approved crushed concrete base;
3. Furnishing, placing, grading, and compacting various thicknesses of approved asphalt base course, ABC-3 or Superpave Type B-12.5;
4. Furnishing, placing, grading and compacting various thicknesses of approved "Type S-1" or "Superpave Type SP-12.5" asphaltic concrete surface course;
5. Restoring 6" thick concrete driveway;
6. Furnishing and installing brick pavement;
7. Furnishing, placing, and grading Type S-III or Superpave "Type SP-9.5" asphaltic concrete;
8. Furnishing and installing all labor, equipment, tools, and materials to saw cut asphalt pavement at the trench site to accomplish a neat square or rectangle perpendicular to the curb;
9. Mechanical milling of 1 inch of existing asphalt including proper disposal of the material;
10. Mobilization required for mechanical milling operations.
11. Furnishing and installing traffic loops as specified and directed by the Engineer;
12. Removing, transporting and disposing of pavement, concrete curb, asphaltic curb and other items removed during construction;
13. Furnishing and installing Traffic Control devices to right-of-way permit requirements;
14. Cleaning up and restoring the job site to its original condition.

The costs to mechanically saw cut pavement joints and the cost to replace all paint striping and pavement markers are considered incidental to pavement restoration and should be included in the cost. Thermo striping will be paid as itemized below.

The cost of removal and disposal associated with all items shall be included in the assigned restoration item. Traffic Control Devices must be removed when the project is complete. The City will not pay for Devices left on site if they are no longer needed. Contractor must keep a record of when individual sites are completed.

City street pavement shall be in accordance with City of Tampa’s PAVEMENT/RIGHT OF WAY RESTORATION REQUIREMENTS – REV-2009 guidelines. See Technical Specifications T4.07

Bricks shall be replaced in accordance with the City of Tampa’s VITRIFIED BRICK REPLACEMENT (REVISED 4/27/2009) guidelines. See Technical Specifications T4.08

The Contractor shall furnish all labor, equipment and material to mobilize to the job site and mill the appropriate thickness and areas of existing asphalt as designated on the plans or as directed by the Engineer in the field. Mobilization shall include all labor, equipment and material and any other preparatory activities necessary to perform the milling activity. Mobilization shall only be paid for milling operations and shall only be paid once per job site unless otherwise approved in advance by the Engineer. Milling shall be made in thickness increments of one inch and shall include proper disposal of the milled material.

The Contractor shall furnish all labor, materials and equipment, necessary to replace and maintain complete the traffic signalization loops as specified and directed by the Engineer. The work includes all saw-cutting of pavement, placement of loop wires and lead-in cables, non-metallic wire hold downs, wire identification tags and sealants, splicing and termination strips, testing and all other work incidental to the installation of a signalization loop complete in place. All signalization loops shall conform to the requirements of the latest edition of the Florida Department of Transportation Standard Specifications for Road and Bridge Construction. Payment for traffic signalization loops will be made at the appropriate contract item unit price per signalization loop installed.

Payment shall be made under:

| <u>Item No.</u> | <u>Description</u> | <u>Unit</u> |
|-----------------|---|-------------|
| 2200 | Furnish, place, and compact lime rock base | CY |
| 2201 | Furnish, place, and compact crushed concrete base | CY |
| 2202 | Furnish, place, and compact ABC-3 asphalt base course | TN |
| 2203 | Furnish, place, & compact Superpave Type B-12.5 asphalt base course | TN |
| 2204 | Restore asphalt concrete surface Type S-1 | TN |
| 2205 | Restore asphalt concrete surface Superpave Type SP-12.5 | TN |
| 2206 | Restore 6" thick concrete driveway | SY |

| | | |
|------|---|-------|
| 2207 | Restore brick pavement | SY |
| 2208 | Furnish, placing and grading Type S-III asphaltic concrete overlay; | TN |
| 2209 | Furnish, place & grade Superpave Type SP-9.5 asphaltic concrete overlay; | TN |
| 2210 | Mechanical milling of asphalt roadways in 1-inch increments to include proper disposal of the milled material | SY-IN |
| 2211 | Mobilization to perform milling operations | EA |
| 2212 | Signalization loops | EA |
| 2213 | Traffic Control Officer (off-Duty Law Enforcement) | MH |
| 2214 | Work Zone Signs | ED |
| 2215 | Business Signs | EA |
| 2216 | Barricades (Temporary - Type II) | ED |
| 2217 | Barricades (Temporary -Type III) (6") | ED |
| 2218 | Advance Warning Arrow Panel | ED |
| 2219 | High Intensity Flashing Lights (Temporary -Type B) | ED |
| 2220 | Variable Message Sign (Temporary) | ED |
| 2221 | 6" Wide Thermoplastic Striping | LF |
| 2222 | 8" Wide Thermoplastic Striping | LF |
| 2223 | 12" Wide Thermoplastic Striping | LF |

C3.00 Roadside Restoration

The Contractor shall provide for all labor, equipment and materials to restore the roadside areas disturbed during the course of the pipeline construction.

Under this section, payment shall be made for:

1. Restoring typical concrete curb and gutter including stabilization of sub-base;
2. Restoring stone or pre-cast curb;
3. Furnishing and placing asphaltic concrete curb;
4. Removing and restoring 4-inch thick concrete sidewalk, including applicable sidewalk ramps;
5. Restoring the roadside area and ditch bottoms and sides with sod shall include furnishing the sod, grading site to its original elevation, and placing the sod;
7. Furnishing and installing detectable warnings on walking surfaces as directed by Engineer. The detectable warning surface will conform to the Florida Department of Transportation Standard Specifications for Road and Bridge Construction, current edition. The detectable warnings shall be installed in conformance with FDOT Standard Indexes 304 and 310 or in conformance with the requirements of the right-of-way regulatory agency with responsibility of the affected right-of-way. (Payment for curb and sidewalk associated with pedestrian access ramps will be made under the appropriate sidewalk and curb pay items.)
8. Cleaning up and restoring the job site to its original condition.

Sidewalk and curb replacement pay quantities shall have maximum limits as specified in these documents, as shown on the plans or as directed by the Engineer. All linear foot units shall be

measured along the curb line. In all cases, the sod or seed placed is to conform in kind to the existing at the particular location.

Payment shall be made under:

| <u>Item No.</u> | <u>Description</u> | <u>Unit</u> |
|-----------------|---|-------------|
| 3000 | Restore concrete Type “D” curb | LF |
| 3001 | Restore concrete Type “F” curb | LF |
| 3002 | Restore stone or pre-cast curb | LF |
| 3003 | Restore asphaltic concrete curb | LF |
| 3004 | Restore 4" thick concrete sidewalk | SY |
| 3005 | Detectable Warning Surface | SY |
| 3006 | Grade and sod roadside, ditch bottoms and sides | SY |

C4.00 Emergency Mobilization

Whenever the Contractor is required to respond to a project in 24 hours or less, an emergency mobilization fee will be allowed. An emergency call out is a request to respond with crews and equipment to a project within 24 hours. All other projects will allow the contractor time to acquire right-of-way permits and maintenance of traffic.

Payment shall be made under:

| <u>Item No.</u> | <u>Description</u> | <u>Unit</u> |
|-----------------|----------------------------|-------------|
| 4000 | Emergency Mobilization Fee | EA |

C5.00 Owner Contingency Allowance

The contingency Allowance shall be used by the City of Tampa as directed by the Engineer. Payment shall be made as a lump sum to pay for furnishing and installing items not listed in the Contract. Contractor shall provide an invoice listing the items and quantities along with the lump sum price. The Engineer may request a cost estimate for a contingency item from the Contractor prior to construction.

Payment shall be made under:

| <u>Item No.</u> | <u>Description</u> | <u>Unit</u> |
|-----------------|-----------------------|-------------|
| 5000 | Contingency Allowance | EA |

C6.00 One-Time Performance Bond Allowance

The One-Time Performance Bond Allowance shall be paid to the Contractor as a lump sum. No allowance will be made for the actual bond cost. Contractor shall provide the performance bond as part of the contract agreement and will be reimbursed with the first work order.

Contractor may submit for payment of this allowance with the first invoice that includes completed work.

Payment shall be made under:

| <u>Item No.</u> | <u>Description</u> | <u>Unit</u> |
|-----------------|-------------------------------------|-------------|
| 6000 | One-Time Performance Bond Allowance | LS |

7.00 Mobilization For Small Projects

Whenever the final cost for a project is \$1000.00 or less, the Contractor shall be paid a mobilization fee of \$350.00. The City expects to issue each project with work at various locations. A project with work at different sites where the cost of the location is less than \$1000.00 but the total of all the sites exceeds \$1000.00 will not be paid a mobilization fee.

A mobilization fee will not be paid on any project where changes to the estimated work exceeds \$1000.00. Maximum payment for any project with the mobilization fee is \$1350.00.

Small project mobilization fee shall be paid as follows:

| <u>Item</u> | <u>Description</u> | <u>Unit</u> |
|-------------|---------------------------------|-------------|
| 7000 | Mobilization for Small Projects | LS |

TECHNICAL SPECIFICATIONS

T1.00 GENERAL REQUIREMENTS

T1.01 Summary of Work

The Contractor shall have access to and inspect each project area prior to beginning construction and ascertain existing conditions as per Section I-2.01 of the Instructions to Bidders.

The work consists of furnishing labor, equipment and materials or labor and equipment only based on the line item descriptions in the Contract Pay Items section of these Specifications. Work shall be performed in a thorough and workmanlike manner, as outlined in Section G-1.02 of the General Provisions. All items implied, usually included, or required for the construction of a complete operating system shall be installed whether or not shown on the plans, in relevant Tampa Water Department Standard Details or specified herein.

The Contractor shall preserve and protect all existing vegetation such as trees, shrubs and grass adjacent to the site, as outlined in Sections G-9.02 and G-9.03 of the General Provisions, which do not reasonably interfere with the construction, as determined by the Engineer. The Contractor will be responsible for all unauthorized cutting or damaging of trees and shrubs, including damage due to careless operation of equipment, stockpiling of materials or tracking of grass by equipment. The Contractor will be liable for, or will be required to replace or restore at no additional expense to the City, all vegetation not protected or preserved as required herein that may be damaged or destroyed.

T1.02 Coordination

The Contractor shall provide for the complete coordination of the construction effort including the work of subcontractors, the effort of independent testing agencies.

It shall be the Contractor's responsibility to alert the Engineer at least two working days in advance of construction, to any conflicts or potential conflicts with the proposed work. Failure of the Contractor to review the job site and alert the Engineer to any conflicts shall relieve the City from compensating the Contractor for any cost arising from any remedial action necessary to resolve the conflict with the proposed work.

In addition, careful coordination with the work of other contractors may be required if other work is underway within the project area.

A toll free number, 811 is available to assist in such coordination efforts with existing utilities. This number is for the utility notification center, a program known as Sunshine811, but may not totally represent all utilities involved in the construction area. The Contractor is responsible for contacting the utility notification center and to immediately notify the Construction Services Professional Engineer (634-3432) of the "Location Request Number" obtained.

The various agencies or utilities possibly affected by the work include but are not necessarily limited to the following:

City of Tampa
 Waste Water Department
 306 E. Jackson St. (390A6N)
 Tampa, FL 33602

City of Tampa
 Transportation Department
 306 E. Jackson St., (290A4E)
 Tampa, FL 33602

City of Tampa
 Storm Water Department
 306 E. Jackson St
 Tampa, Fl 33602
 Hillsborough County
 Planning & Development Mgmt. Dept.
 P.O. Box 1110
 Tampa, FL 33601

Florida Dept. Transportation
 2820 Leslie Rd
 Tampa, FL 33619
 Hillsborough County ROW Management office
 601 E. Kennedy Boulevard
 Tampa, Florida, 33601

All utilities shall be kept in operation except with the express written consent of the utility owner. It will be the Contractor's responsibility to locate and preserve existing utilities. Any and all damage to existing utilities as a result of the Contractor's actions shall be repaired to the satisfaction of the utility owner and the City at the Contractor's expense.

T1.03 Abbreviations and Symbols

Various abbreviations and symbols may be used or referenced in these specifications and contract plans. Symbols are generally explained on the sheet of the plans entitled "Location Map, Legend and General Notes". Abbreviations commonly used, along with their full reference, are as follows:

- | | | | |
|-----|---------------|---|---|
| 1. | Cu. Yds. (CY) | - | Cubic Yards |
| 2. | FDEP | - | Florida Department of Environmental Protection |
| 3. | DIP | - | Ductile Iron Pipe |
| 4. | DIPRA | - | Ductile Iron Pipe Research Association (formerly CIPRA) |
| 5. | FDOT | - | Florida Department of Transportation |
| 6. | EA | - | Each |
| 7. | Lin. Ft. (LF) | - | Lineal Foot |
| 8. | HDPEP | - | High Density Polyethylene Pipe |
| 9. | LS | - | Lump Sum |
| 10. | mg/l | - | Milligrams per Liter |
| 11. | NSF | - | National Science Foundation |
| 12. | OSHA | - | Occupational Safety and Health Administration |
| 13. | ppm | - | Parts per Million |
| 14. | psi | - | Pounds per Square Inch |
| 15. | PVCP | - | Polyvinyl Chloride Pipe |

| | | | |
|-----|---------------|---|------------------------------------|
| 16. | RPR | - | Resident Project Representative |
| 17. | S.P. | - | Steam Pressure |
| 18. | Sq. Ft. (SF) | - | Square Feet |
| 19. | Sq. Yds. (SY) | - | Square Yards |
| 20. | TN | - | Ton |
| 21. | W.O.G. | - | Water, Oil, Gas |
| 22. | HDD | - | Horizontal Directional Drilling |
| 23. | MJ | - | Mechanical Joint |
| 24. | FL | - | Flanged Joint |
| 25. | CIP | - | Cast Iron Pipe |
| 26. | NAVD88 | - | North American Vertical Datum 1988 |
| 27. | TWD | - | City of Tampa Water Department |
| 28. | MOT | - | Maintenance of Traffic |
| 29. | MH | - | Man Hours |
| 30. | ED | - | Each Day |

T1.04 Submittals, Shop Drawings, Product Data and Samples

When asked to supply materials, the Contractor shall submit 4 copies of shop drawings as stated in Article G-3.02 of the General Provisions, plus those copies necessary for his own requirements in accordance with Section 3 of the General Provisions. The shop drawings shall have been checked and stamped approved by the Contractor and identified as the Engineer may require. This data shown in the shop drawings shall be complete with respect to dimensions, design criteria, materials of construction, and the like, to enable the Engineer to review the information required. The data shown on the shop drawings shall include, in addition to that specified in the General Provisions, reference to specification section, drawing number, item identification on catalog cuts and like information to expedite review. Incomplete submissions will be returned without action.

Items that are on the Water Department's pre-approved material list will not be required to go through the shop drawing submittal process, provided that the list of materials is submitted to and approved by the Engineer in advance of the start of construction.

The Engineer will review and return one (1) set of the shop drawings along with those sets submitted by the Contractor over and above the quantity required by Article G-3.02 of the General Provisions. The returned sets shall bear the Engineer's comments and shall be returned with reasonable promptness. The Contractor's stamp of approval on any shop drawing shall constitute a representation to the Engineer that the Contractor has either determined and verified all field construction criteria, materials, catalog numbers and similar data or he assumes full responsibility for doing so, and that he has reviewed or coordinated each shop drawing with the requirements of the work, contract documents and technical specifications.

The Engineer's review of a shop drawing is only for general conformance with the design concept of the project, and shall not relieve the Contractor from his responsibility for and deviation from the requirements of the contract documents or technical specifications, unless the Contractor has, in

Contract 14-C Water Restoration Contract writing, called the Engineer's attention to such deviation at the time of the shop drawing submission and the Engineer has given written approval to the specific deviation. Any review by the Engineer shall not relieve the Contractor from his responsibility for errors or omissions in the shop drawings.

One complete set of reviewed shop drawings, product data and samples shall be kept at the site at all times. During the work specified as shown on the shop drawings, the Contractor shall make no deviations from the reviewed drawings, and the changes made thereon by the Engineer, if any.

When required by the Engineer, shop drawings or product data shall be submitted for, but shall not be necessarily be limited to, the following:

- Asphalt mix design
- Concrete mix design, reinforcing steel

Whenever a standard of quality is established by a reference specification, the Contractor shall submit a certificate by the manufacturer that the material supplied meets the requirements of both these technical specifications and the referenced specifications and standards.

T1.05 Quality Control

In addition to the inspection and testing outlined in Section 5 of the General Provisions, compaction/density tests also shall be required.

For tests required by the Technical Specifications regarding soil compaction, asphalt testing and concrete cylinder strength, the City's Construction Services will perform inspection and testing. The City will perform inspections, tests, and other services specified individual specification Sections and as required by the Engineer. The Contractor shall coordinate with the City to furnish samples of materials, design mix, equipment, tools, storage and assistance as requested. Retesting required due to non-conformance with specified requirements shall be performed by the City.. Payment for retesting will be charged to the Contractor by deducting inspection or testing charges from the Contractor's payment.

T1.06 Materials and Equipment

A) General

Materials and equipment incorporated into the work shall meet the requirements of these specifications. The Contractor shall furnish satisfactory evidence of the quality and kind of materials and equipment as well as guarantees or warranties provided by the manufacturer. It will be necessary to submit a copy of all delivery tickets for materials used on the project, regardless of the basis of payment.

Materials, supplies or equipment to be incorporated into the work shall not be purchased by the

Contractor or subcontractors subject to a chattel mortgage or under a conditional sale contract or other agreement by which an interest is retained by the seller.

All materials and equipment shall be applied, installed, connected, erected, used, cleaned, finished and conditioned in accordance with the instructions of the applicable manufacturer, fabricator or processor except as otherwise provided in the Contract Documents.

B) Quality Standards

If a standard of quality for items of equipment is established by reference on the plans or in the specifications to specific manufacturer's products, materials or construction and/or fabrication, items of equipment shall equal or exceed the standard of the referenced product as outlined in Section G-4.05 of the General Provisions.

The Engineer shall be the sole judge of material or equipment equality. The burden of proof of equality rests with the Contractor. Qualities described and shown refer to minimum criteria the Engineer will use in considering equipment proposed for the project.

It is not the intent of the Contract Documents to function as proprietary specifications. Where a particular manufacturer make and model are cited and specifically required for interchangeability of parts and to match existing equipment, this has been stated in the specifications.

C) Transportation and Handling

Materials and equipment shall be loaded and unloaded by methods affording adequate protection against damage. Every precaution shall be taken to prevent injury to protect the integrity of the material during transportation and handling. Suitable power equipment will be used and the material or equipment shall be under control at all times.

Materials that are rejected shall be immediately removed from the site. The materials shall be replaced that meets all requirements of the contract documents.

D) Storage and Protection

Materials and equipment shall be stored in a manner and at a location acceptable to the Engineer to insure the preservation of their quality and fitness for the work and which precludes damage or injury and affords protection against weather staining or vandalism.

Replacement of materials or equipment damaged, destroyed or lost through improper, inadequate or careless storage shall be the Contractor's responsibility.

T1.07 Cleaning and Restoring

Prior to final acceptance, all rubbish and unused material due to or connected with the construction shall be removed and the premises left in a condition acceptable to the City. All damaged areas shall be repaired, and all excess earth and rubble removed. Payments due may be withheld due to failure to comply with these requirements.

Any and all existing facilities and/or conditions shall be restored to original condition or better before final payment and acceptance is made by the City.

T2.00 RESTORATION

T2.01 WASTE MATERIAL DISPOSAL

The Contractor shall remove and dispose of all debris and excess spoil resulting from clearing, demolition and excavation operations. Natural waterways or bodies of water shall not be used for disposal or debris.

All debris shall be disposed of at a site approved and permitted by the State for such disposal. Clean spoil may be disposed on private property only with written authorization of the property owner.

T2.02 PAVEMENT/RIGHT OF WAY RESTORATION REQUIREMENTS – Rev. 2009

SEE PAVEMENT STANDARD DETAILS

Pavement Options:

| PAVEMENT *(Classification) | BASE MATERIAL (Section 1-2) | CONCRETE (Section 1-3) | ASPHALT SURFACE (Section 1-4) | FULL DEPTH ASPHALT (Section 1-5) |
|-------------------------------|--------------------------------|---------------------------|----------------------------------|-------------------------------------|
| A | 6" | 4" | 1" | 5" |
| I | 8" | 6" | 2" | 7" |
| II | 12" | 8" | 3" | 10" |

***Classification:**

- Class A: Alleyways, Residential and Low Volume Commercial Driveways
- Class I: 2-Lane Residential Streets and High Volume Commercial Driveways
- Class II: Multi-Lane or High Volume 2-Lane Streets (most depicted by centerline markings)

Notes:

- 1) If existing roadway is stabilized, increase base material thickness by 50 %
- 2) If original pavement exceeds max. 3" ,match the existing asphalt thickness
- 3) Minimum 4" of shell marl, crush concrete, or asphalt millings placed in unimproved (dirt) trafficked right-of –way
- 4) Concrete shock pad required for any utility repaired/ installed less than 30" (needs C.O.T. Engineer approval)

- 5) Brick pavement shall be restored as specified in Section 1-6 Brick Replacement

SECTION 1

PAVEMENT RESTORATION SPECIFICATIONS

- 1-1 BACKFILL and SUBGRADE:** Replace and compact clean sub-grade material classified as A-1, A-2, A-3. Backfill shall be free of objectionable material (bricks, broken pavement, concrete, clay, muck, etc.). If flowable fill is used both mix and installation shall conform to FDOT Standard Specifications for Road and Bridge Construction (January 2000), Section 121-1 through 121-6.
- 1.1 Density Requirements:** Material shall be compacted in lifts not to exceed 12". Densities are required at alternative 1' lifts of vertical fill above excavation bottom of trench and for each prepared trench segment, not to exceed 200'. Density test is not to be taken through succeeding layers. The final subgrade density test shall be taken at elevation beneath Base Material or Full depth.
- 1.2 Density Specification:** Shall meet 98% compaction of AASHTO T-180.
- 1-2 BASE MATERIAL:** Approved by a City of Tampa D.P.W. Engineer and/or meeting the FDOT Standard Specifications for Road and Bridge Construction (January 2000). Submittal may be requested by C.O.T.
- 2.2 Acceptable Materials:** Limerock, Shell Marl, Crushed Concrete, Concrete (3000 min. PSI), and Asphalt Plant Mix.
- 2.3 Density Requirements:** Place and compact in two lifts. Asphalt Plant Mix shall be compacted in accordance to Section 1-4. Densities are required for each trench segment at final grade, not to exceed 200'.
- 2.4 Density Specifications:** Shall meet 98% compaction of AASHTO T-180.
- 1-3 CONCRETE:** 3000 PSI minimum 28 days strength. Placed on compacted, moistened subgrade. Consolidate and cure. Do not load for 72 hours.
- 3.1 Concrete Specifications:** Density test of subgrade may be required at the Inspector's discretion.
- 1-4 ASPHALT SURFACE:** Sawcut all sides a minimum of 6" from replaced base. Paint with RC 70 (or equal) tack. Place and compact in lifts S-1 or S-3 type asphalt plant mix. The finished pavement is subject to inspection and approval by City of Tampa D.P.W. Engineer.
- 4.1 Density Requirements:** Type S-1 lift to be 1 ¼" min. and 3" max. (if lift exceeds 2", compact with a drum roller type compactor). Type S-3 lift to be ¾" min. and 1 ½" max.

4.2 Density Specifications: Quality assurance testing of the asphalt may be required at the Inspector's discretion. (generally: 96 percent compaction of asphalt plant mix design bulk specific gravity)

1-5 FULL DEPTH ASPHALT: Same as requirements for Section 1-4 ASPHALT SURFACE

1-6 BRICK REPLACEMENT: Brick shall be re-laid according to Section 2 PROCEDURES. Place and grade 1 ½" of sand over base or concrete. Place brick uniformly, staggered with respect to the adjacent course. Any work area disturbing a street listed as a "Historical Street" shall be required to replace original brick. The contractor is responsible for safe storage of materials until such time the brick is re-laid.

6.1 Base Options:

- A) Limerock, Shell Marl: shall meet Section 1-2 BASE MATERIALS, requires brick joints to be sealed with Asphaltic Steep #7330 or Surebond 1300 Sealer.
- B) Crush Concrete: Shall meet Section 1-2 BASE MATERIALS, requires brick joints to be sealed with 1:4 sand cement mixture (slurry or moistened to ensure that cement sets).
- C) Concrete: shall meet Section 1-3 CONCRETE, 4" of concrete is used as base material, requires brick joints to be sealed with 1:4 sand cement mixture (slurry or moistened to ensure that cement sets).

6.2 Density Requirements: Subgrade material shall meet Section 1-1 BACKFILL and SUBGRADE. Base material shall meet Section 1-2 BASE MATERIAL.

6.3 Density Specifications: Shall meet 98% compaction of AASHTO T-180.

SECTION 2

PAVEMENT RESTORATION PROCEDURES

GENERAL:

The Permit holder is to contact D.P.W. Technical Services at (813) 635-1949 or Fax. 622-1956, 48 hours prior to starting permitted work. **The material testing results should be forwarded to the department/inspection group performing the inspection**

Testing/Inspection shall be scheduled with D.P.W. Materials Testing and Inspections on any part of the replacement work. Tests will be performed by the City's Testing/Inspections Lab or an approved private engineering testing laboratory. **Contact: (813) 635-3408.**

The Foreman on each project shall maintain on-site, copies of the approved Department of Public Works "Application and Permit for Construction and Maintenance Operations within Public Rights of Way, including plans, drawings, and the Pavement Restoration Requirements – 2003.

Copies of all applicable material delivery tickets and copies of all test results not taken by D.P.W. Materials Testing and Inspections, shall be forwarded to D.P.W. Technical Services at 3806 26 Ave East, Tampa, Fla. 33605. Fax number (813)-622-1956.

EXCAVATION:

Utility installations shall be placed a minimum of 30” below grade. If, because of utility conflicts or unusual conditions, the 30” minimum depth requirement cannot be maintained, special authorization may be granted for installation at a lesser depth. Installations shall maintain the 30” depth, unless special authorization is granted in writing, by the D.P.W. Engineer.

All trench widths under pavement, including driveways, are to be a minimum of 18”, to allow mechanical compaction of backfill and base. Density tests are required and restoration shall meet SECTION 1.

Where pavement and/or base are undermined, disturbed, or otherwise damaged, such areas shall be cut away and the pavement replacement work extended to correct such conditions.

Tunneling under driveways, sidewalks, curbing, retaining walls, and pavement shall not be allowed unless approved prior to work is given by C.O.T. Engineer.

When obstructions are encountered in driving or jacking, pipe shall be cut off, left in place, and filled with a flowable fill type grout to prevent the formation of voids.

Edges of jacking pits, directional bore pits, exit pits, trenches, etc. shall be a minimum distance, equal to the depth of the pit excavation, from any pavement, curbs, sidewalks, or other structures. If this distance cannot be maintained, backfill shall be compacted in lifts not to exceed 12” and density tests taken as outlined in SECTION 1-1.

Ditches shall be restored promptly to prevent the formation of sediment in the existing drainage system. Erosion control shall be enforced. The existing ditch grade and cross section profile shall be maintained. The City will require sodding, sprigging, or seeding and mulching to restore stable cover of vegetation on ditch banks, shoulders, and other areas disturbed by construction. Vegetation restoration will be kept moist and maintained until well established. Staking of sod will be required if ditch slope exceeds 4:1.

Erosion control shall abide by Erosion Control Methods set forth in C.O.T: D.P.W. Standard Drawings where applicable

Lawn and landscaped areas shall be restored to original or better condition. Each situation may require individual attention and differing restoration procedures.

CONCRETE

Concrete sidewalks, driveways or pavement affected by construction operations will be corrected by removing and replacing full panels. Cuts in concrete sidewalks or driveways shall be sawed in straight lines at panel joints and replaced to full panels.

Concrete replacement shall be a minimum thickness of 6" for driveways and 4" for sidewalks. Concrete and density requirements shall meet SECTION 1-3.

Concrete curb and gutter will be formed and placed as a single unit to conform to City of Tampa Standards.

Expansion joints shall be provided at not more than 50' intervals on curb and sidewalk replacement work.

Expansion material shall be used where new concrete meets existing. Sidewalks shall have tooled construction joints or sawed control joints at 5' intervals for 5' wide sidewalk and 6' intervals for 6' wide sidewalk

BRICK:

Brick pavement shall be re-laid as called for by the street replacement schedule and on a complete and accepted base with a sand cushion and only clean whole, sound brick shall be used.

Brick replacement consists of bringing the area to be repaved to a subgrade and base conforming to the required grade and cross section of uniform density ready to receive the brick. Material and density requirements shall meet SECTION 1 1-6.

Any part of the subgrade and base area inaccessible to the mechanical compactor shall be compacted by hand or power tamping in a manner acceptable to the engineer.

The brick shall be laid in straight courses, flat on the prepared sand cushion, with the better side of face upward.

The brick shall be laid in close contact and the joints of each course shall be uniformly staggered with respect to adjacent courses. Whole brick shall be used except in starting or finishing a course and in fitting around manhole tops or structures. In general, not less than ¼ of brick shall be used in batting.

The joints shall be filled in accordance with SECTION 1 1-6.1. The 1:4 sand/cement mixture shall be "soupy" and swept in with street brooms or may be dry mixed, swept in with street brooms, consolidated by vibratory methods, and sufficiently moistened to ensure that cement sets. Excess grout shall be removed from surface.

Joint filler shall take place immediately to prevent joints from filling with foreign matter.

ASPHALT:

Asphalt pavement edges of cuts are to be sawed in straight lines parallel and perpendicular to pavement edges. One uniform parallel line for paving shall exist along edge outside trenchline. When the existing asphalt is less than 3" thick, pavement shall be cut and removed for a minimum distance of 6" from edge of the trench.

Tack coat shall be applied to the surface of the pavement base and adjoining asphalt butted edge joint. **No** “feathering” of asphalt at the joint will be allowed. These areas are to be free of all loose material and foreign matter before applying tack coat.

Asphalt pavement installation shall be rolled in place in a controlled pattern with a mechanical compactor capable of sufficiently applying enough loads to meet density requirements in accordance with SECTION 1-4.2 .

If an asphalt overlay is called for, a string line must be used while spreading the material, to obtain neat patches with straight edges. Where a cut is adjacent to or within 3’ of a previous patch, the pavement replacement and/or resurfacing shall be extended to include the previous patch.

Final surface restoration must be completed to the City’s standards and the City reserves the right to require the entire roadway surface width to be overlaid to lengths determined by the City.

Upon completion of the roadway surface, the contractor shall replace all damaged pavement markings per City standards.

TEMPORARY RESTORATION

Temporary pavement surfaces and sub surface materials shall be restored conforming to all requirements regarding configuration, thickness, and density as detailed in SECTION 1. The pavement shall be temporary finished with a suitable grade of asphalt and sand to provide a temporary-wearing course and to eliminate a dust nuisance. Temporary pavement shall be restored with the proper **permanent** surface within specified time period stated in the legal Permit for Construction and Maintenance Operations within Public Rights of Way.

SODDING

Scarify or loosen the areas requiring sod to a depth of 6 inches. Prior to sodding, thoroughly water area and allow water to percolate into the soil.

Place sod immediately after ground preparation. Do not use sod that has been cut for more than 72 hours.

Do not sod when weather and soil conditions are unsuitable for proper results. Do not place sod on eroded or washed out sites.

Place the sod on the prepared surface, with edges in close contact and embed it firmly and smoothly by lightly tamping with appropriate tools.

Thoroughly water the sod immediately after placing. Use watering equipment that will prevent damage to the finished surface. Keep the sod in a moist condition until well established.

T2.03 VITRIFIED BRICK REPLACEMENT (REVISED 4/27/2009)

Subgrade:

This work consists of bringing the area to be repaved to a subgrade conforming to the required grade and cross section surface of uniform density ready to receive the base course. This is to be accomplished by excavating or backfilling as needed, shaping, and then rolling the entire area with an approved self-propelled tandem roller weighing not less than 8 tons. Shaping and rolling to continue until subgrade has been properly prepared and shows that no further compaction of any practical benefit would result from continued rolling. It shall be tested as to cross section, crown and elevation. After being properly prepared, it shall be so maintained until the base course is constructed. A completed subgrade shall be maintained sufficiently in advance of the base course operations to permit of proper control. Any part of the subgrade area inaccessible to the roller shall be thoroughly compacted by hand or power tamping in a manner acceptable to the engineer. Subgrade shall be minimum 12" and be compacted to 98% per AASHTO T-180.

Base:

This work consists of placing 10" of crushed concrete base material atop the prepared and accepted subgrade. The base will be placed in at least two lifts. The 10" crushed concrete will have a minimum LBR of 100 and will be compacted to 98% per AASHTO T1-80.

Where a base is encountered under the brick pavement, it shall be restored to the same thickness with the approved crushed concrete material before relaying the brick pavement.

Sand Cushion:

A sand cushion shall be constructed on all completed bases for vitrified brick pavement. The sand cushion shall be sharp sand composed of clean sand, free from clay, loam and other foreign matter, and shall be constructed to a uniform thickness of 1-inch upon the completed crushed concrete base. The sand cushion shall be prepared at least 25 feet in advance of laying the brick where possible. Care shall be exercised that the sand cushion is not disturbed or compacted until the bricks are in place and are ready for rolling.

Vitrified Brick Pavement:

Vitrified brick pavement shall be re-laid at locations called for by replacement schedule for street paving disturbed by construction operations, as shown on the plans. Vitrified brick pavement shall be re-laid on a completed base with a sand cushion and only clean whole, sound bricks shall be used. Acceptable brick removed from the disturbed areas removed by the contractor and/or removed from the City of Tampa stock pile, will be used for this repaving and shall not be hauled or moved by the contractor for use elsewhere unless directed by the engineer.

The brick shall be laid on straight courses, flat on the prepared sand cushion, with the better side of

the face upward. The brick shall be laid in close contact and the joints of each course shall be uniformly staggered with respect to adjacent courses. Whole brick shall be used except in starting or finishing a course and in fitting brick pavement around manhole tops or other structures. In general, not less than one-fourth of brick shall be used in batting.

A timber straight edge shall be driven against each fourth course of brick by light blows with a sledge or maul to straighten the lines and eliminate appreciable space between the bricks.

The surfaces shall be swept clean and rolled with a tandem static roller weighing not less than 5 and no more than 8 tons in a manner to firmly embed each brick in the sand cushion so that the completed pavement shall conform to the required crown, grade, and cross section.

The joints of the vitrified brick pavement replacement shall then be filled with a 1:4 sand/cement mixture and/or pure sand. If pure sand, the pure sand must be sealed with Surebond SB-1300 Sealer or approved equal. The 1:4 sand/cement mixture of mortar grout shall be “soupy” and swept in with street brooms **or may be dry mixed, swept in with street brooms, consolidated by vibratory methods, and sufficiently moistened to ensure that cement sets.** If “soupy” application is used, then Contractor will blot the joints with sand after sweeping application to remove excess grout.

The application joint filler should take place immediately after laying the brick or as soon as possible thereafter to prevent joint from filling with other foreign matter.

T2.04 PAVEMENT MARKING

Where shown or required for repaired/replaced pavement, pavement marking shall be painted with thermoplastic markings.

Thermoplastic compound sealing primer and glass spheres shall meet the requirements of FDOT Standard Specifications, Sections 711 and 971, or the requirements of the governing permitting agency.

Pavement marking of repairs/replacements shall match the previously existing pavement where applicable. Where markings are required other than replacement of previously existing markings, the Contractor shall follow the requirements of the U.S. Department of Transportation, Manual of Uniform Traffic Control devices for streets and Highways. Application of thermoplastic markings shall comply with FDOT Standard Specifications, Section 711, or the requirements of the governing permitting agency. Reflective pavement markers (RPMs) shall be installed to match the pattern in place prior to the start of construction.

STANDARD DETAILS FOR RESTORATION WITHIN ROADWAY

(Details Modified From FDOT Design Standards Index 307))

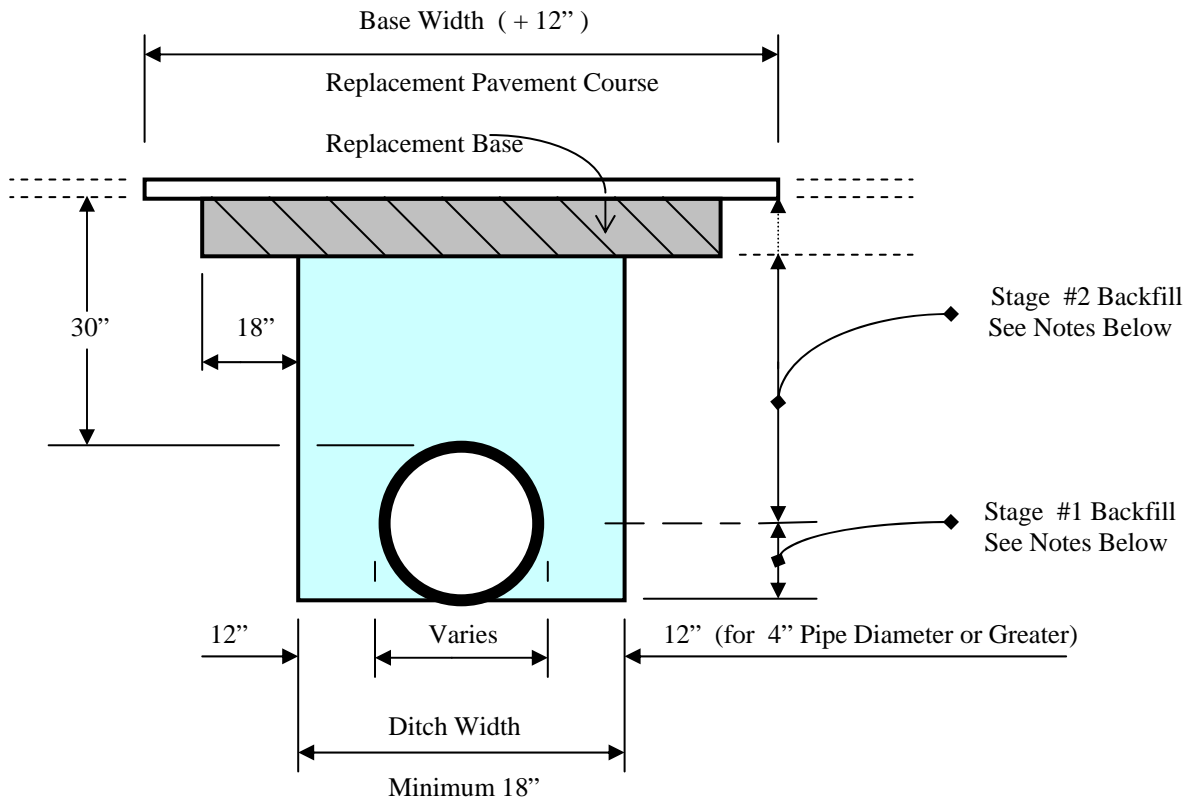

FLEXIBLE PAVEMENT NOTES:

Pavement shall be mechanically sawed.

Pavement, Base, and Backfill material shall be placed in accordance with **City of Tampa Pavement Restoration Requirements – 2009**

In Stage #1, construct compacted fill beneath the haunches of the pipe, using mechanical tamps suitable for this purpose. This compaction applies to the material placed beneath the haunches of the pipe and above any bedding.

In Stage # 2, construct compacted fill along sides of the pipe and up to the bottom of the base. Compact material using mechanical tamps suitable to achieve Density meeting 98% of AASHTO T-180, lifts not to exceed 12" compacted.

If mechanical compaction is difficult to achieve, then flowable fill may be used. In Stage #1, place flowable fill midway up on both sides of the utility. Allow to harden before placing Stage #2. If a method is provided to prevent floatation from occurring, Stage #1 and #2 can be combined, if approved by the Engineer.

Note: Specification Standards and Requirements not illustrated shall meet latest FDOT Standard Specifications.

STANDARD DETAILS FOR RESTORATION WITHIN ROADWAY

(Details Modified From FDOT Design Standards Index 307))

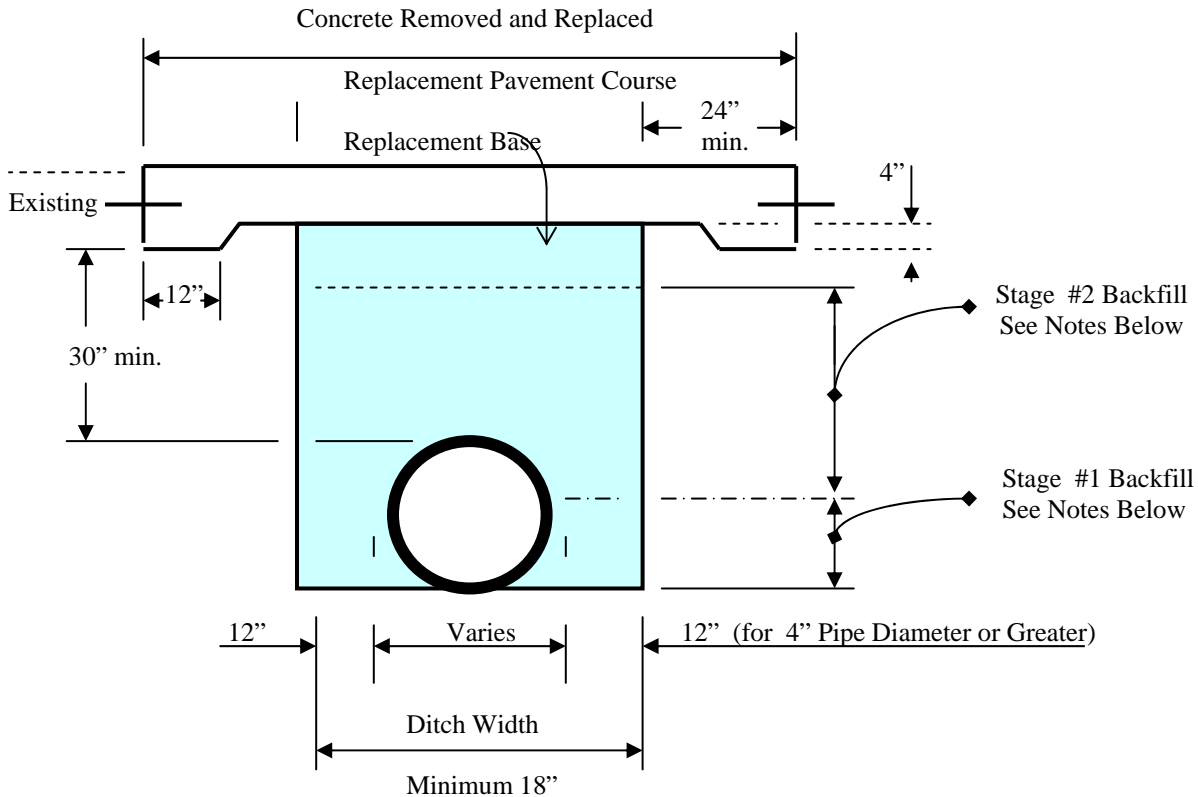

RIGID PAVEMENT NOTES:

Pavement shall be mechanically sawed and restored to conform with existing pavement joints.

High early strength cement concrete (3000 psi) meeting the requirements of FDOT Standard Specification 346 shall be used for rigid pavement replacement.

Pavement, Base, and Backfill material shall be placed in accordance with **City of Tampa Pavement Restoration Requirements – 2009**

In Stage #1, construct compacted fill beneath the haunches of the pipe, using mechanical tamps suitable for this purpose. This compaction applies to the material placed beneath the haunches of the pipe and above any bedding.

In Stage #2, construct compacted fill along sides of the pipe and up to the bottom of the base. Compact material using mechanical tamps suitable to achieve Density meeting 98% of AASHTO T-180, lifts not to exceed 12" compacted.

If mechanical compaction is difficult to achieve, then flowable fill may be used. In Stage #1, place flowable fill midway up on both sides of the utility. Allow to harden before placing Stage #2. If a method is provided to prevent floatation from occurring, Stage #1 and #2 can be combined, if approved by the Engineer.

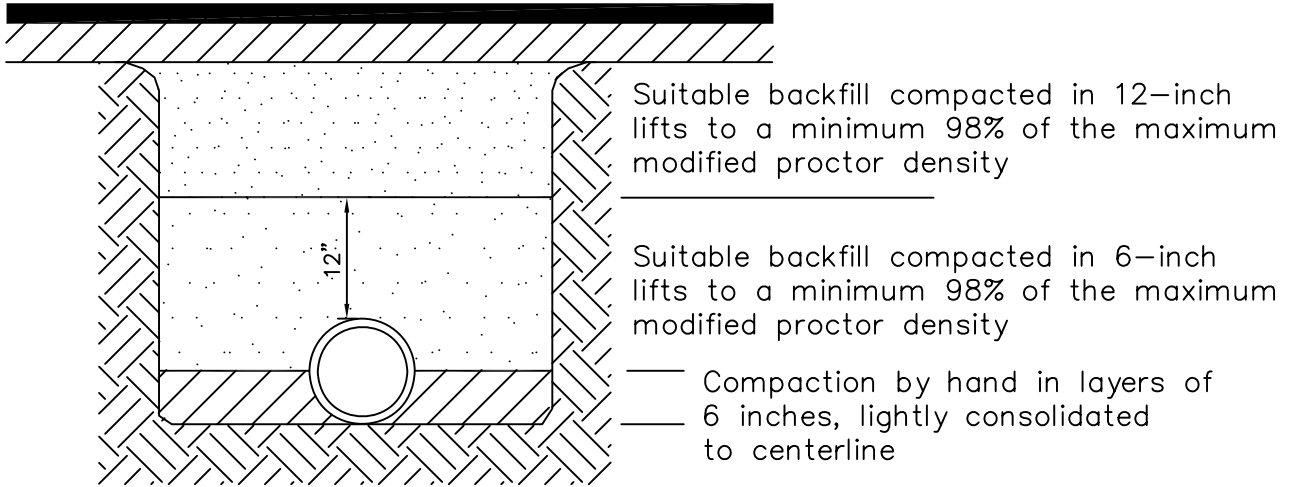

NOTES:

1. Type 2 trench is defined as a flat-bottom trench. Lightly consolidate backfill to centerline of pipe.
2. This standard shall be utilized in the absence of specific standards. The standard of the agency controlling the Right-of-Way shall govern unless otherwise directed by the Engineer.
3. Suitable backfill shall be defined as material free from cinders, ashes, refuse, clay, organic matter, boulders, rocks or stones, or other material that in the opinion of the Engineer is unsuitable.
4. Non-pervious areas shall mean any concrete or asphalt curb, sidewalk, trail, driveway, or roadway.

| | | | | |
|---------------------------------------|---------------------------------------|--|--|-------------|
| <p>TAMPA WATER DEPARTMENT</p> | <p>APPROVED <u>Sept. 2011</u></p> | <p>REVISED _____ _____ _____</p> | <p>TRENCHING, BEDDING AND BACKFILL DETAIL FOR NON-PERVIOUS (paved) AREAS</p> | <p>2.01</p> |
|---------------------------------------|---------------------------------------|--|--|-------------|

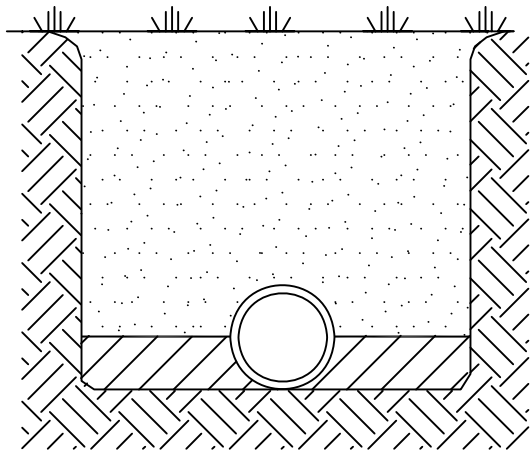

Suitable backfill compacted in 12-inch lifts to a minimum 95% of the maximum modified proctor density

— Compaction by hand in layers of 6 inches, lightly consolidated to centerline

NOTES:

1. Type 2 trench is defined as a flat-bottom trench. Lightly consolidate backfill to centerline of pipe.
2. This standard shall be utilized in the absence of specific standards. The standard of the agency controlling the Right-of-Way shall govern unless otherwise directed by the Engineer.
3. Suitable backfill shall be defined as material free from cinders, ashes, refuse, clay, organic matter, boulders, rocks or stones, or other material that in the opinion of the Engineer is unsuitable.
4. Non-paved area is a pervious area. If any part of the trench is within a concrete or asphalt curb, sidewalk, driveway, or roadway, then Standard Detail 2.01 applies.

| | | | | |
|---------------------------------------|---|--|--|-------------|
| <p>TAMPA WATER DEPARTMENT</p> | <p>APPROVED <u>Sept. 2011</u> _____</p> | <p>REVISED _____ _____ _____</p> | <p>TRENCHING, BEDDING AND BACKFILL DETAIL FOR PERVIOUS (non-paved) AREAS</p> | <p>2.02</p> |
|---------------------------------------|---|--|--|-------------|

City to provide neighborhood symbol decal

Project Manager:

Dan Peterson, P.E.
Construction Engineer
City of Tampa

Phone: (813) 635-3432
Email: daniel.peterson@tampagov.net

contractor name here

City of Tampa Improvement Project

brief project description (2 – 3 lines)

total appropriated cost (round off) – duration of construction

Scheduled for completion in (date)

supplemental project description (max. 2 lines)

For information, please call : (813) 635-3400

DETAIL 1

- NOTES:
1. Letter Color : Black Font : Times New Roman, bold
 2. Background Color (front, back and edges) : Benjamin Moore Paint, Natural Wicker OC-1.
 3. Post Color: Black
 4. Contractor shall verify text with the City prior to sign fabrication.

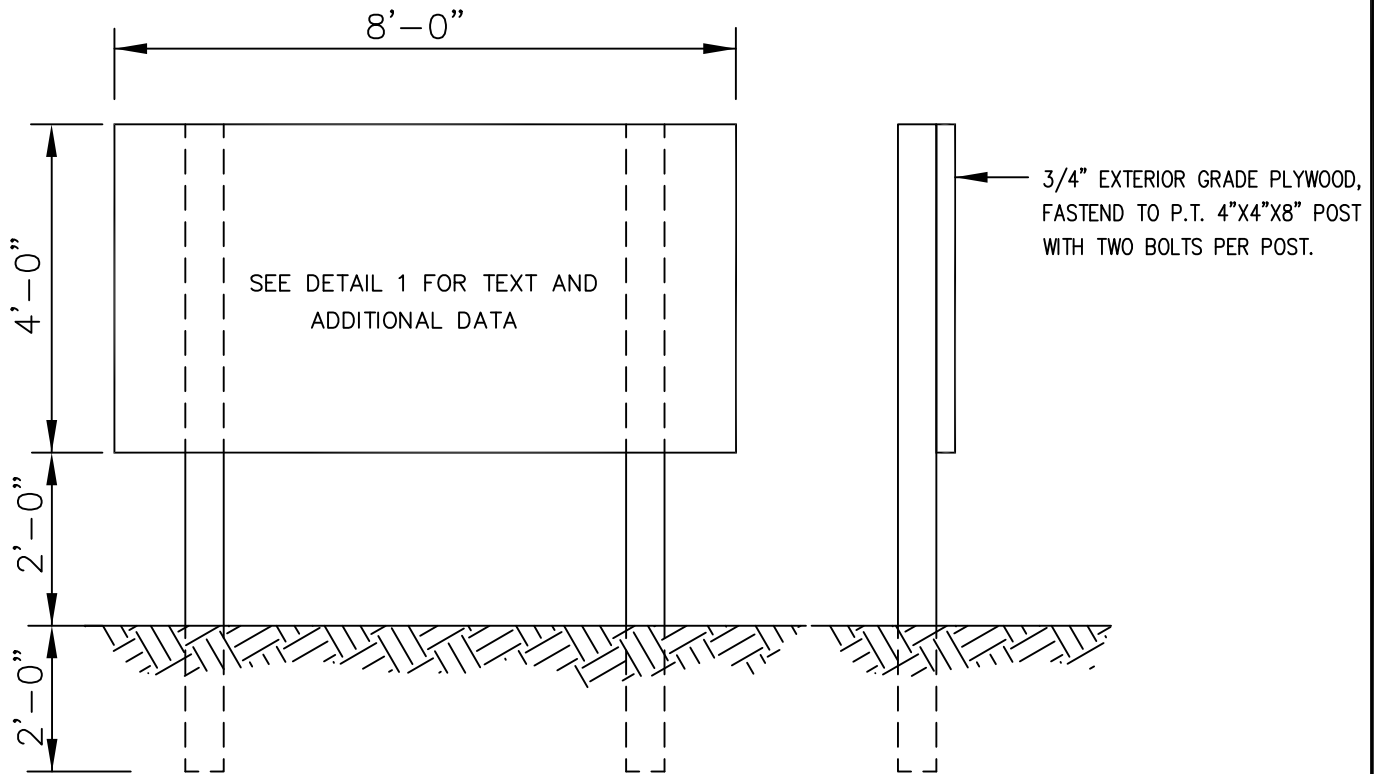

DETAIL 2

NOT TO SCALE



TAMPA
WATER
DEPARTMENT

APPROVED
Oct., 2013

REVISED
JRD 10/13

CITY OF TAMPA
PROJECT SIGN

9.01