



Development and Growth Management Development Coordination

Division

Exhibit A-1: Reasonable Reconfiguration For Variance Review Board (VRB) APPLICATION FOR TREE REMOVAL

This Exhibit supplements the VRB application for the applicant seeking permitting for Tree Removal in the City's Accela Citizen Access (ACA) system. The VRB Application for Tree Removal guidelines are derived from Chapter 27 of the City of Tampa Code of Ordinances, Zoning and City Policy, and regulations governing Tree Protection and Mitigation.

Please refer to [Chapter 27, Article VI, Division 4](#), Subdivisions 1 and 2, and Section Tables 27-284.2.4 and 27-284.2.5 regarding Reasonable Reconfiguration for protected and grand trees.

Required Information

- The electronic VRB application (including an owner/agent affidavit and a Site Plan): for VRB application and Site Plan instructions, including public notice information, see [Variance Review Board Application](#),
- Two (2) alternative plans showing that design alternatives were considered prior to the removal determination: please see [Section 27-156](#) Table 4-2 Note 7 for allowable setback reductions for the purpose of tree(s) preservation,
- A Tree/Topo/Boundary Survey (prepared by a surveyor or mapper showing the protective radii of all protected/grand trees on the parcel indicating the location, scientific name, and diameter breast height (DBH) of any tree on the subject parcel within twenty (20) feet of the perimeter of the subject parcel as well as the crown spread and crown area of grand trees), verified and signed by either a private arborist or Natural Resources through a tree consultation (see example diagram attached), and
- Any other plans for development that have been considered for the subject parcel.

Please state the impact of the protective radii on any existing or proposed structure:

Please state any other pertinent information that you would like the Variance Review Board to consider when make its determination of reasonable reconfiguration:

Property Address (List all):

What is the development history of the subject parcel?

Are there any special circumstances affecting the development of the parcel?

What is the existing development pattern on similarly situated parcels near the subject property?

What were the tree regulations in effect at the time you purchased the property?

KEY

- - - Property Line
- - - Principal Structure Buildable Area Boundary
- - - Tree Removal Zone Boundary
- (GT) Grand Tree
- (ST) Specimen Tree
- (PT) Protected Tree
- - - (GT-PRZ) Grand Tree - Protective Root Zone
- - - (ST-PRZ) Specimen Tree - Protective Root Zone
- - - (PT-PRZ) Protected Tree - Protective Root Zone
- - - (Palm/SOT-PRZ) Palm/Small Ornamental Tree - Protective Root Zone

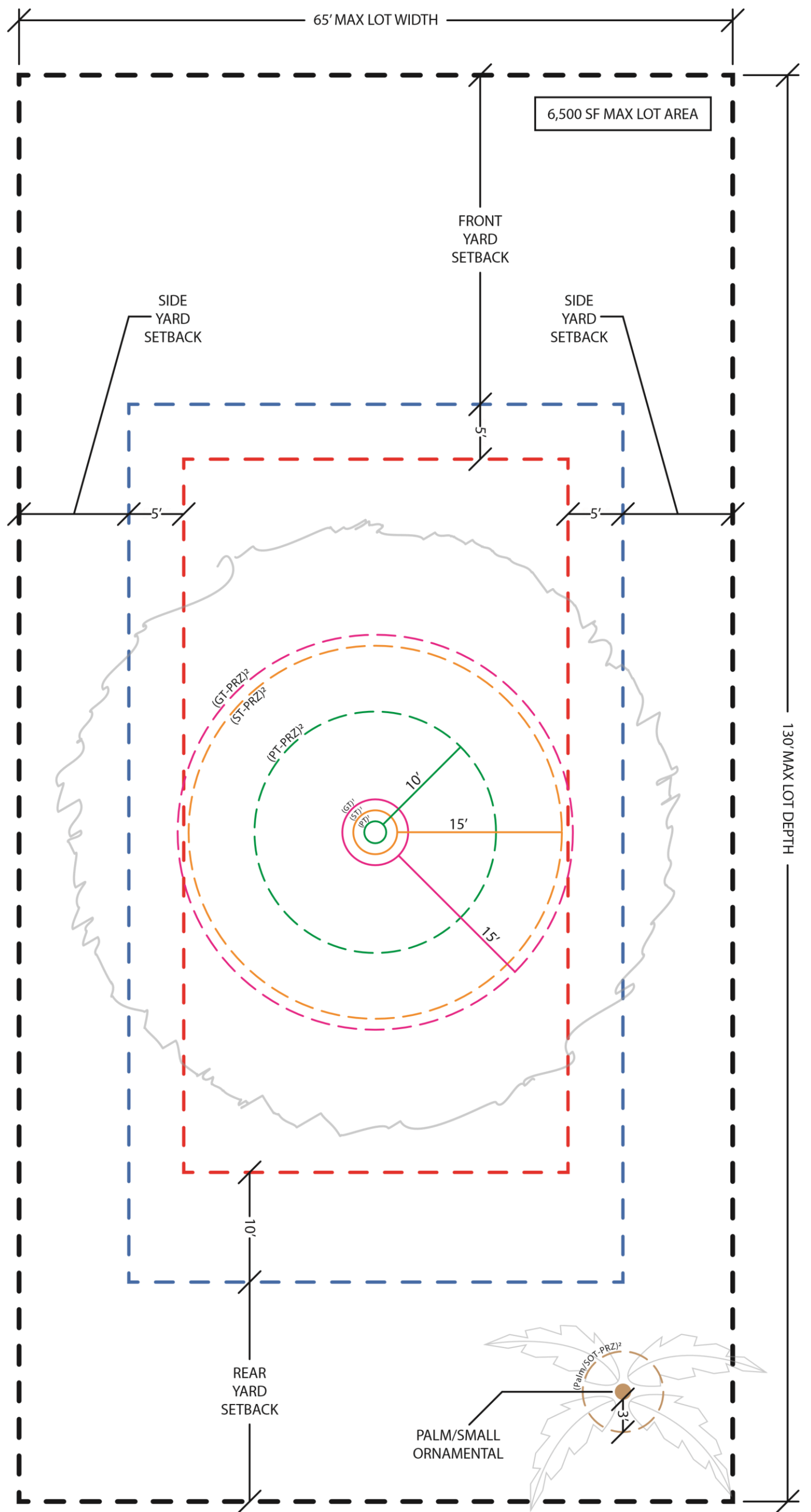

Diagram - Tree Removal Survey detail example